



# Archived Content

**Information identified as archived is provided for reference, research or recordkeeping purposes. It is not subject to the Government of Canada Web Standards and has not been altered or updated since it was archived. Some of this archived content is available only in one official language. Translation by CMHC can be requested and will be provided if demand is sufficient.**

# Contenu archivé

**Le contenu identifié comme archivé est fourni à des fins de référence, de recherche ou de tenue des dossiers; il n'est pas assujéti aux normes Web du gouvernement du Canada. Aucune modification ou mise à jour n'y a été apportée depuis son archivage. Une partie du contenu archivé n'existe que dans une seule des langues officielles. La SCHL en fera la traduction dans l'autre langue officielle si la demande est suffisante.**

Cal  
MH  
90D61  
c. 1

**BUILDERS' SERIES**

# ***Drywall Application***

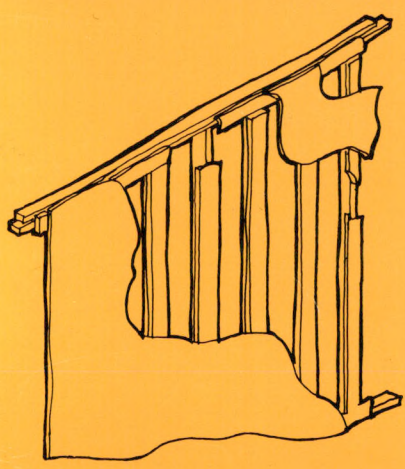

Canada Mortgage and Housing Corporation  
supports the Government of Canada  
policy on access to information for people  
with disabilities.

If you wish to obtain this publication  
in alternative formats, call (613) 748-2367.

cal  
MH  
90061  
c.1

# **Drywall Application**

Canada Mortgage and Housing Corporation (CMHC) offers a wide range of housing-related information. For details, contact your local CMHC office or the Canadian Housing Information Centre, Canada Mortgage and Housing Corporation, 700 Montreal Road, Ottawa, Ontario K1A 0P7.

CMHC subscribes to Canada's Green Plan. Quantities of our publications are limited to market demand; updates are produced only when required; and recycled or recyclable stock and non-toxic inks are used wherever possible.



---

Cette publication est aussi disponible en français sous le titre  
*La pose des plaques de plâtre (LNH 5887)*

The information contained in this publication represents current research results available to CMHC, and has been reviewed by a wide spectrum of the housing industry. The Corporation, however, assumes no liability for any damage, injury or expense that may be incurred or suffered as the result of the use of this publication.

© 1986, Canada Mortgage and Housing Corporation  
Second edition 1988.  
Revised and reprinted: 1990  
Reprinted 1992, 1994

Printed in Canada

# **Contents**

Introduction	<b>1</b>
Problems	
Nail pops	<b>2</b>
Cracking at intersection of partition and ceiling	<b>6</b>
Other types of cracking	<b>10</b>
Sagging or wavy ceilings	<b>14</b>
Visible joints, ridging and tape delamination	<b>16</b>
Deterioration in high-moisture areas	<b>20</b>
Terms and Definitions	<b>21</b>
Additional Reading	<b>22</b>

# ***Introduction***

Drywall is one of the two major areas of warranty complaints — the other being foundation problems. As well as having a high degree of visibility, drywall is expected to cover the “sins” of other construction methods and materials.

Drywall application depends heavily on previous trades, especially framers. Over the years, gypsum board has replaced plaster, a material that was able to conform to greater surface variations. Drywall application has also become highly competitive with little or no apprenticeship training to maintain acceptable standards.

There is now a greater frequency of problems with drywall application because of wetter lumber, thicker insulation, faster scheduling and increased winter construction.

The information in this guide is not intended as a complete course in drywall installation. Rather, it attempts to identify the most common problems, probable causes and recommended solutions.

“Drywall” is used herein for gypsum board.

## Problem

Nail pops

## Cause

Wet framing lumber

Framing lumber should not exceed a moisture content of 19 percent (the maximum allowed by the National Building Code). However, in many parts of the country, and particularly in Eastern Canada, the moisture content of framing lumber is often much higher. As this lumber dries to 12-14 percent (6-9 percent in mid-winter and in drier climates), shrinkage occurs, the stud pulls away from the gypsum board, and any subsequent movement of the board causes the nail to "pop." A 10 percent change in moisture content can cause a spruce or fir stud to shrink up to 6 mm (1/4") (see fig. 1).

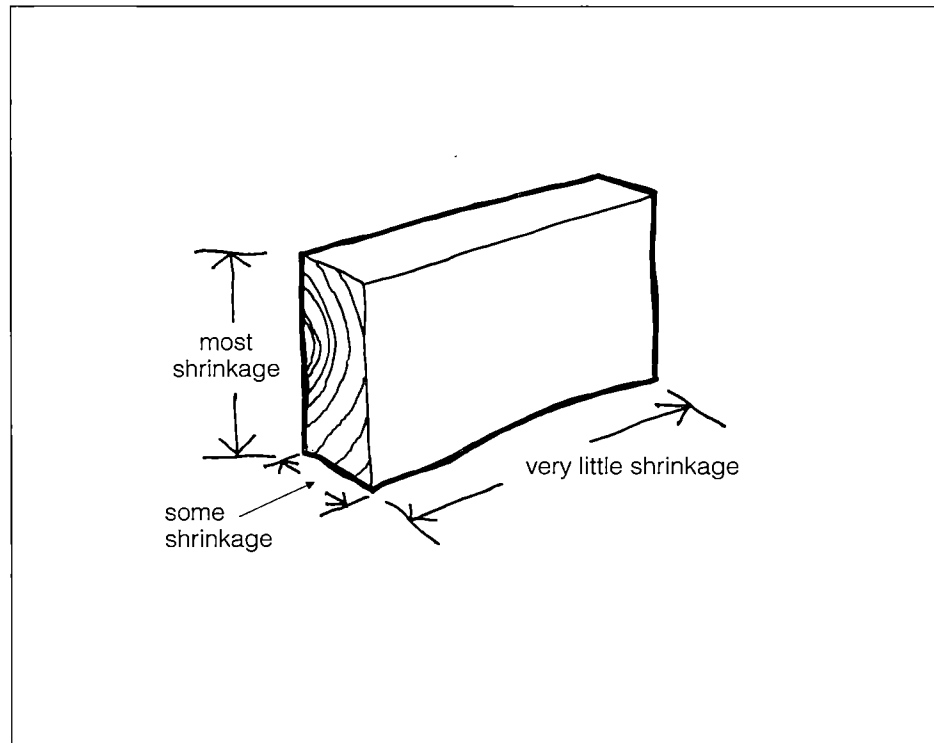

Fig. 1. Framing lumber shrinkage

## Solutions

- Start with 14 percent moisture content if possible. (This may be beyond a builder's control, unless kiln-dried lumber is economically available.) Avoid lumber that is grade stamped green; for example, choose "S-DRY" versus "S-GRN."
- Store framing lumber close to where it will be used, and protect from rain and direct sunlight where possible.
- If obtaining good quality lumber presents a problem, investigate the use of metal studs.

## Cause

Misaligned or warped studs, uneven joist depth

## Solutions

- Inspect the framing before applying gypsum board. Alignment should not vary by more than 6 mm (1/4").
- Strap ceilings with 38 x 38 mm (2 x 2) for nails, 19 x 64 mm (1 x 3) for screws.
- Have framers align crowns in the same direction. Straighten warped studs by saw-cutting the concave or hollow side, driving wedges and nailing scabs (fig 2).
- Avoid protrusions from blocking or cross-bridging (fig. 3).

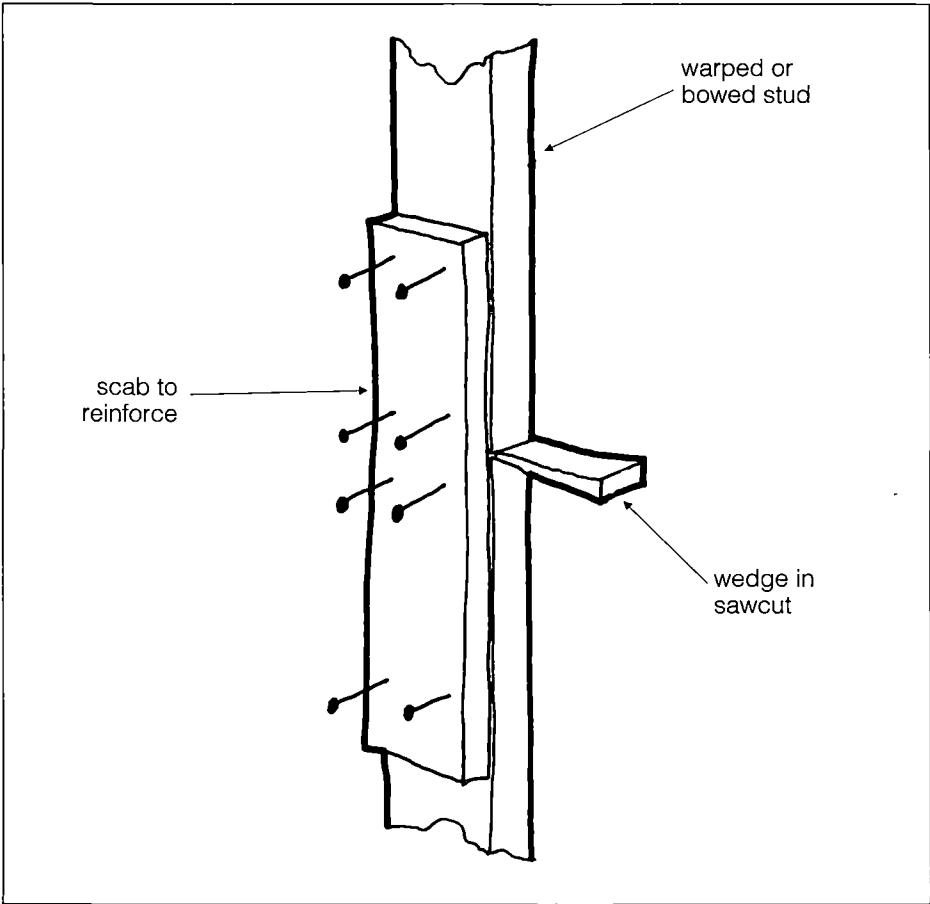

Fig. 2. Straightening warped studs

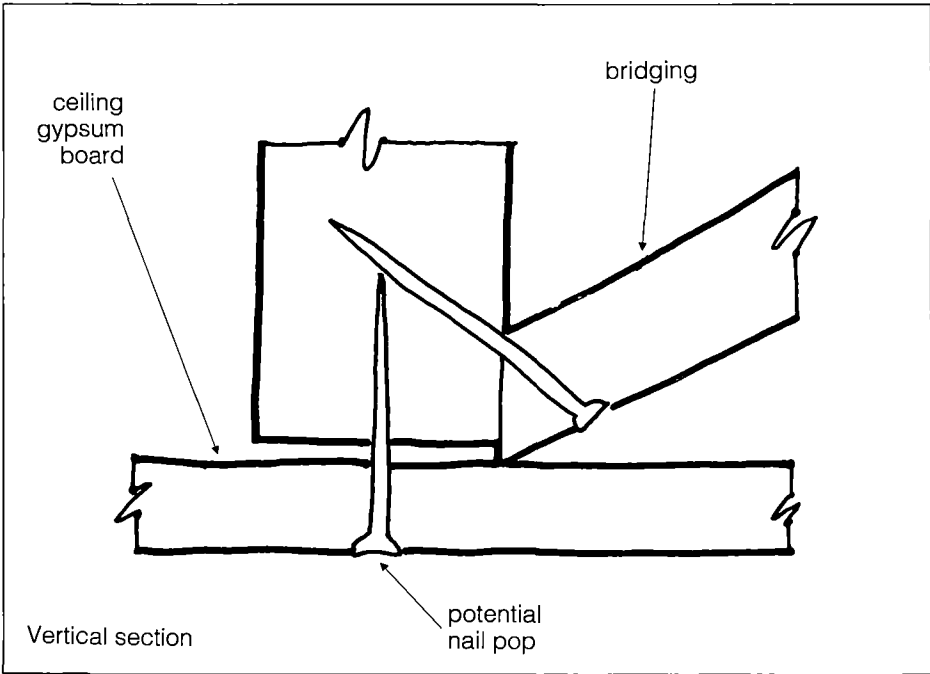

Fig. 3. Avoid protrusions

## Problem: Nail pops

### Cause

Fastener length and type

*Longer fasteners actually worsen the problem of nail pops, since shrinkage takes place over a greater length of nail (fig. 4).*

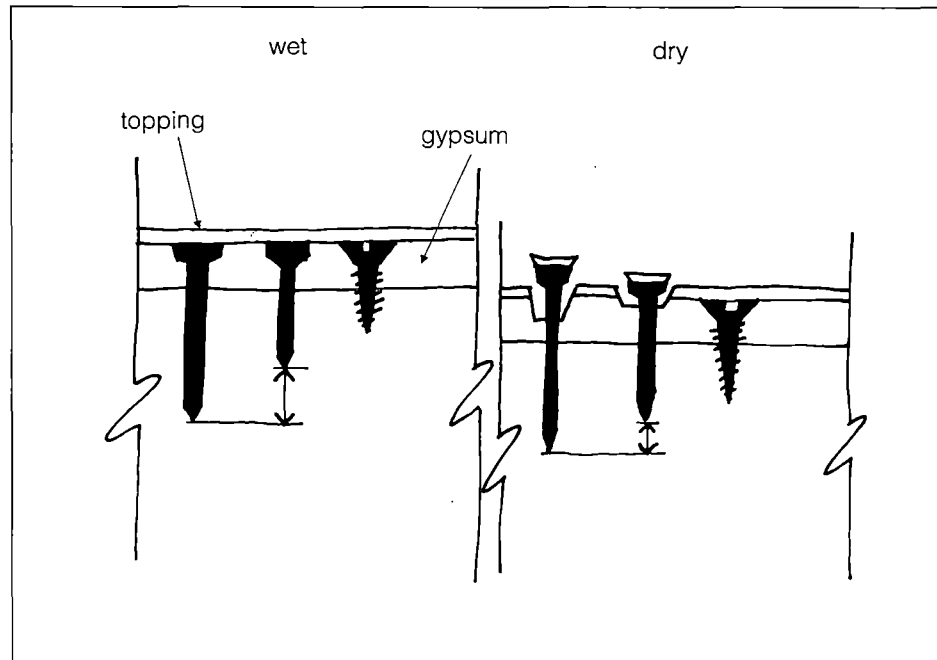

Fig. 4. Nail popping (exaggerated)

### Solutions

- Use code minimums: 32 mm (1-1/4") for nails and 29 mm (1-1/8") for screws with 13 mm (1/2") board (fig. 4).
- Use screws where possible. They have more than three times the holding power of nails and therefore greater resistance to seasonal cycling (shrinkage and swelling), virtually eliminating fastener pops.
- Some builders suggest that screws with a coarse thread have greater resistance to popping.

### Cause

Fastening techniques

*It can be difficult to hold the board and nail at the same time. Thicker insulation often prevents good contact between board and framing.*

### Solutions

- Apply hand or mechanical pressure when fastening to ensure that the board is making contact with the framing.
- Tack board in place, then return to complete nailing or screwing.
- Use double nailing or screwing to draw the board tighter to the stud (fig. 5).
- Stagger fasteners to reduce the diagonal distances between nails or screws.
- Consider using adhesives instead of mechanical fasteners. On exterior walls, apply over gypsum strips nailed to studs over the vapour barrier (fig. 6).
- If a nail or screw breaks the surface of the paper, it loses its hold on the board. Drive a second fastener close to the first.

### Cause

Vibration

*Exterior fastening to brick ties, siding, or trim can loosen drywall nails.*

### Solutions

- Schedule boarding after most exterior work has been completed.

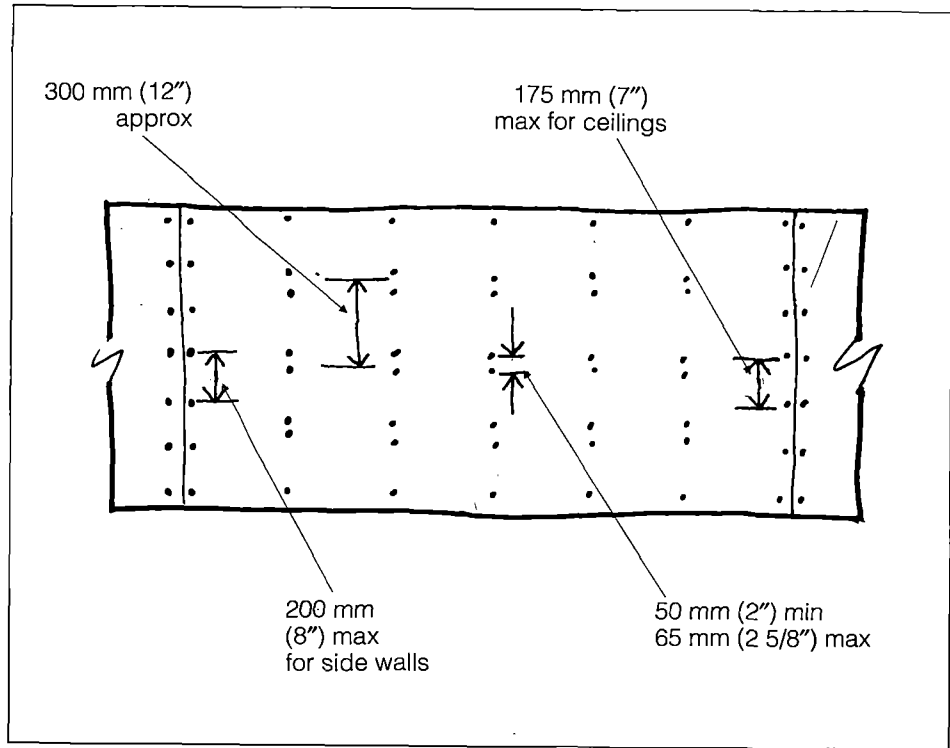

Fig. 5. Double nailing

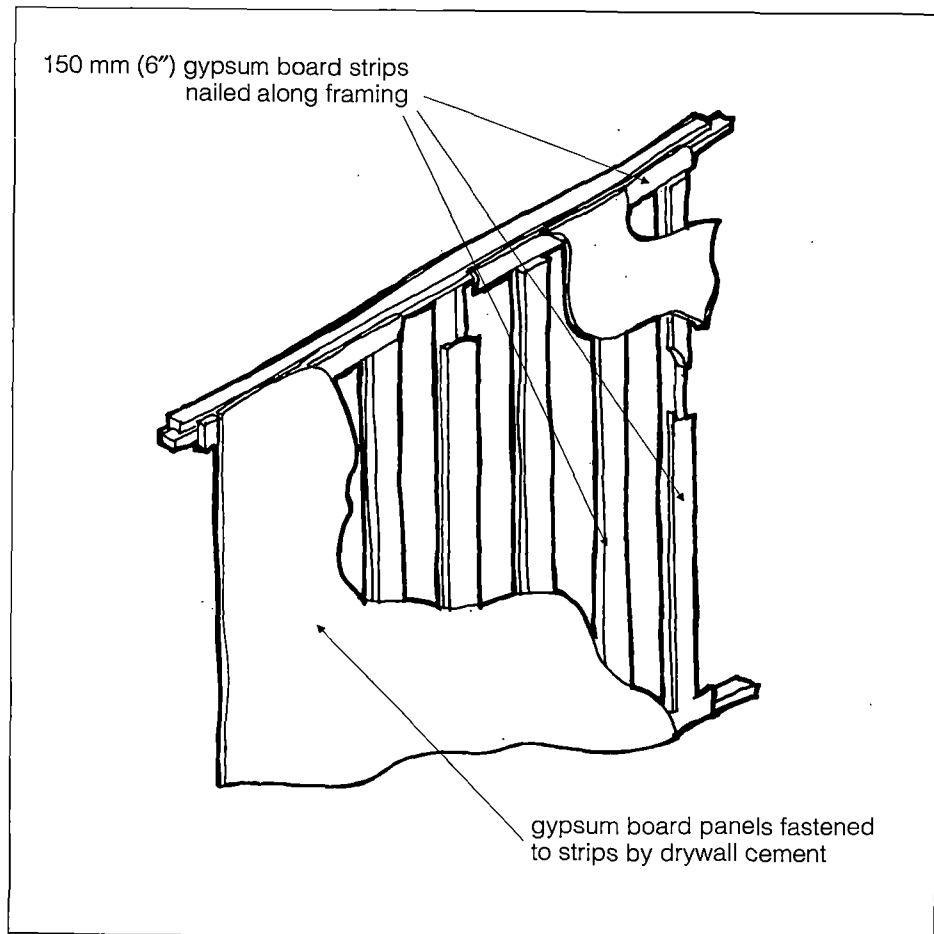

Fig. 6. Strip laminating application

## Problem

Cracking at intersection of partition and ceiling

## Cause

Truss uplift

*As lumber dries in roof trusses, shrinkage occurs. Since the bottom chord is warmer and drier due to attic insulation, it may shrink more than the top chord. The top chord may actually lengthen in some circumstances if it absorbs moisture. This differential shrinkage causes the truss to bow upwards (fig. 7). Cracks at the intersection of the ceiling and partition walls may open during the winter and close in the summer. Generally, such problems are worse during the first year after construction, when the house is drying out.*

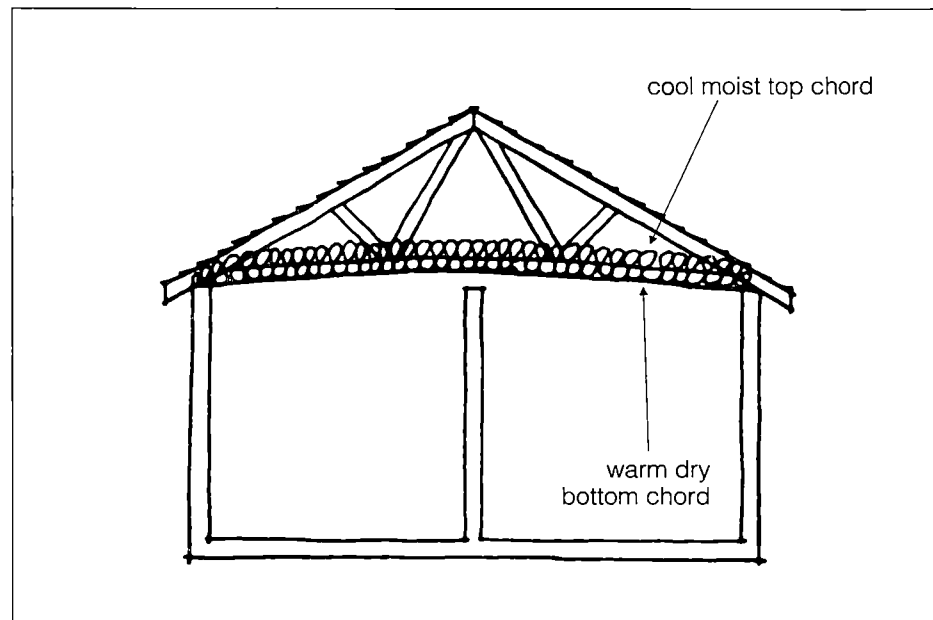

Fig. 7. Differential shrinkage

## Solutions

- Minimize the potential for differential shrinkage:
  - use trusses made from kiln-dried wood
  - store trusses where they will be kept as dry as possible on site
  - sheath the roof as quickly as possible after truss erection
  - ensure airtight ceiling construction to prevent moisture from entering the attic space
  - provide adequate attic ventilation.
- Minimize the length over which truss uplift can occur:
  - use short truss spans aligned with house width rather than house length
  - use two monopitch trusses in place of a single long-span truss
  - use steeper sloped trusses.
- Use "floating corners" to hide the effects of truss uplift. Fasten both the ceiling drywall and the partition wall drywall away from the corner joint (fig. 8). This technique uses the natural flexibility of drywall to allow uplift of 50-75 mm (2-3") to occur without cracking the corner joint. Recommended minimum float distances are:
  - 300 mm (12") for 13 mm (1/2") ceilings
  - 400 mm (16") for 16 mm (5/8") ceilings
  - 200 mm (8") for partition walls

**Problem: Cracking at intersection of partition and ceiling**

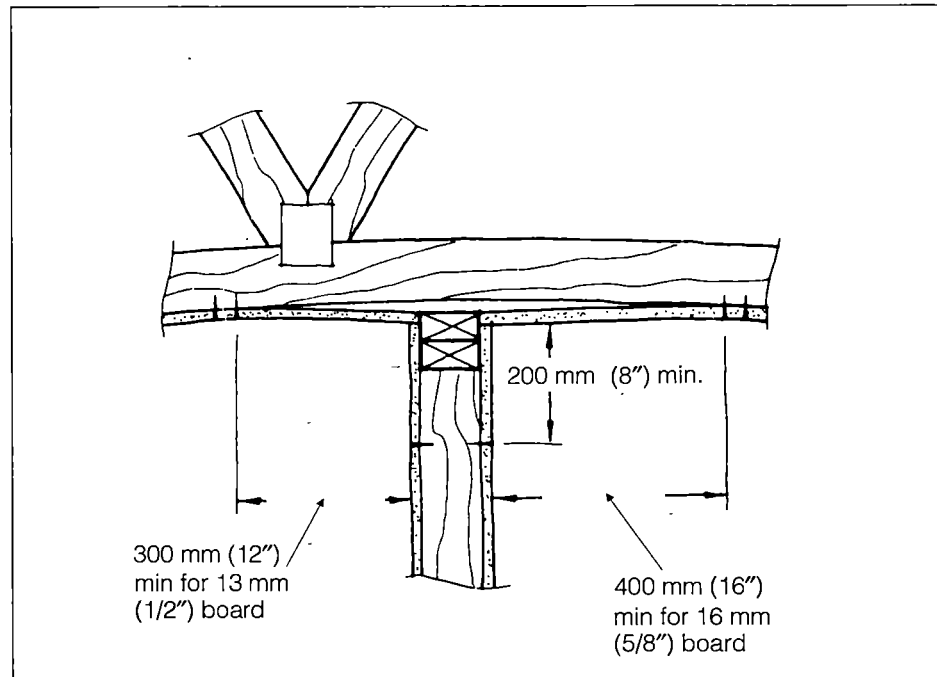

Fig. 8. Floating corners

- With floated corners, double the first row of fasteners to prevent pull-through.
- Ensure strong corner joints. Avoid scoring paper tape with the trowel. Joints made with fibreglass tape are approximately twice as strong as those with paper tape.
- Reduce the stress on corner joints by holding the ceiling drywall to the top plate with drywall clips, with wood blocks or with wider top plates and strapping. Drywall clips can be attached to the ceiling drywall or to the wall framing before the drywall is installed. Clips are usually spaced at 600 mm (24"). Consult manufacturers for recommended installation practices (*fig. 9*). Some builders have also used cornerbead to hold down the ceiling boards

**Note:** Gypsum manufacturers recommend against floating the ceiling more than 600 mm (24"). For exterior walls, wall panels should be fastened to the top plate for improved racking resistance and hold-down capacity.

**Problem: Cracking at intersection of partition and ceiling**

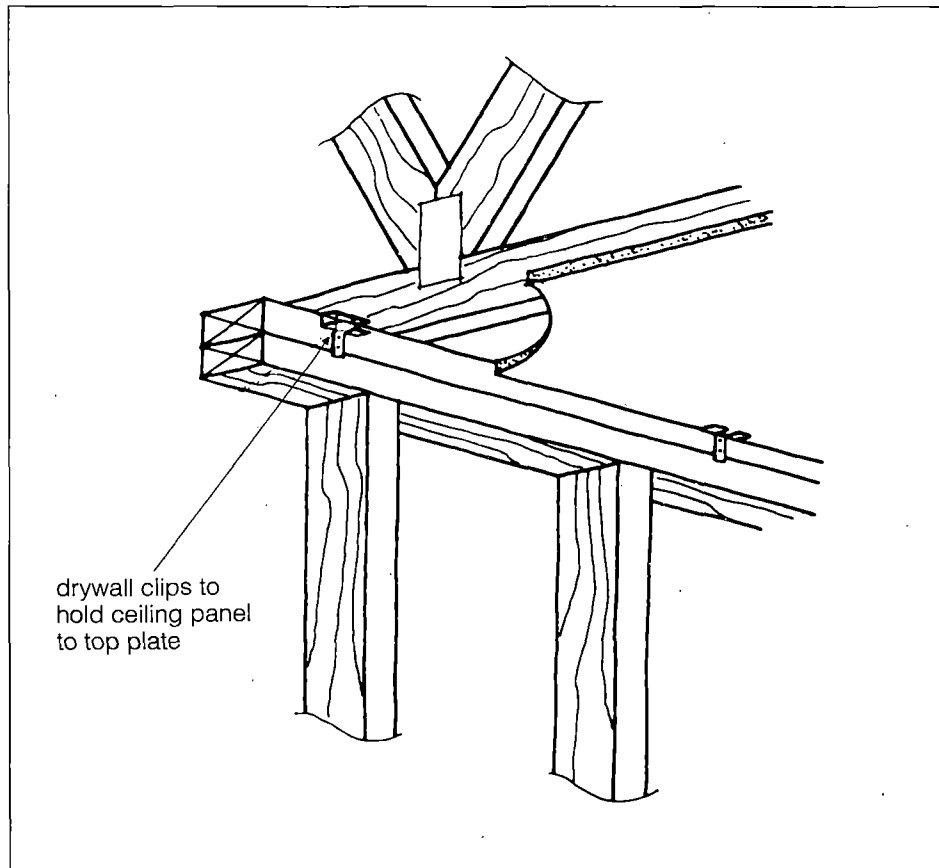

Fig. 9. Drywall clips

- Do not try to prevent truss uplift by fastening the trusses more securely to the partition walls — this may actually lift the walls off the floor. Lightly fasten trusses to partition walls or leave them free standing.

**Note:** Trusses must be securely attached to exterior walls to prevent wind uplift on the roof.

- Where partitions run parallel to roof trusses, and where trusses are too close to the partition to permit floating, provide blocking between trusses (fig. 10) or use strapping.

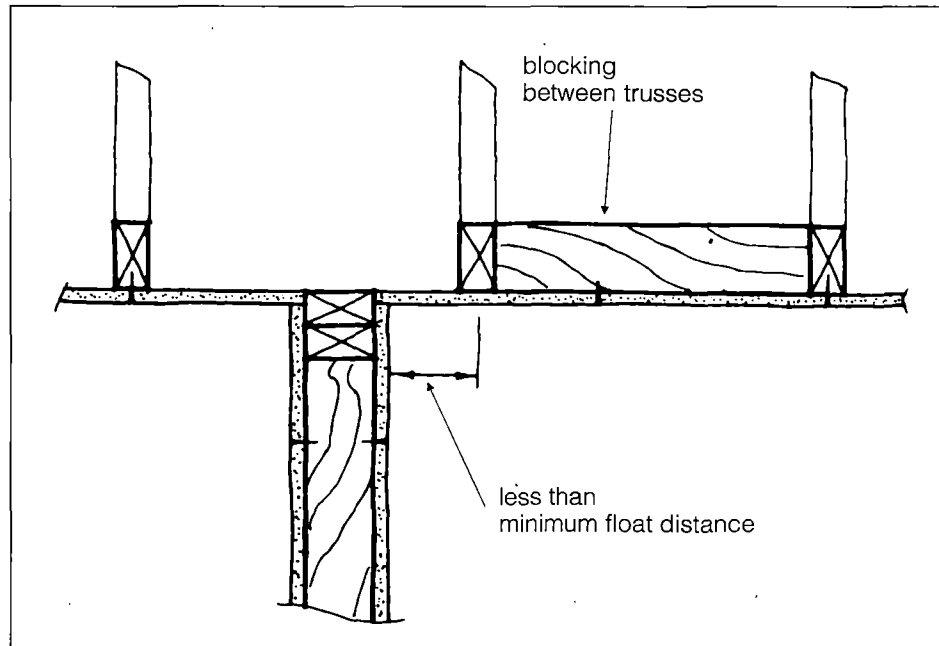

Fig. 10. Partition parallel to trusses

**Problem: Cracking at intersection of partition and ceiling**

- The general use of ceiling strapping is recommended, as it allows maximum float distances, reduces stress on the drywall, and results in flatter ceilings. Types of strapping include 19 x 64 mm (1 x 3), 38 x 38 mm (2 x 2) and resilient channels. Strapping can be combined with wider top plates or nailers to hold down the ceiling drywall (*fig. 11*).

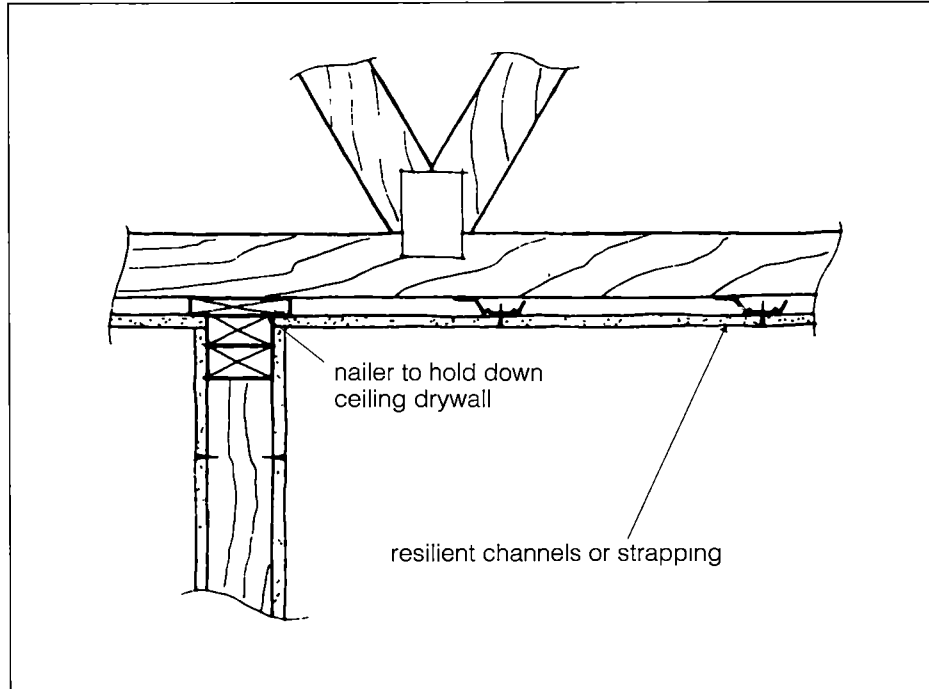

Fig. 11. Strapping

- If truss uplift occurs, fasteners in the ceiling drywall near the corner joint can be driven through and the joint retaped to create a floating corner. Alternatively, mouldings can be attached to the ceiling (not to the walls) to cover the crack at the joint and to create a slip joint (*fig. 12*). Do not attempt to remedy truss uplift by driving wedges between the trusses and the partition walls. This can cause serious structural problems when the truss settles later.

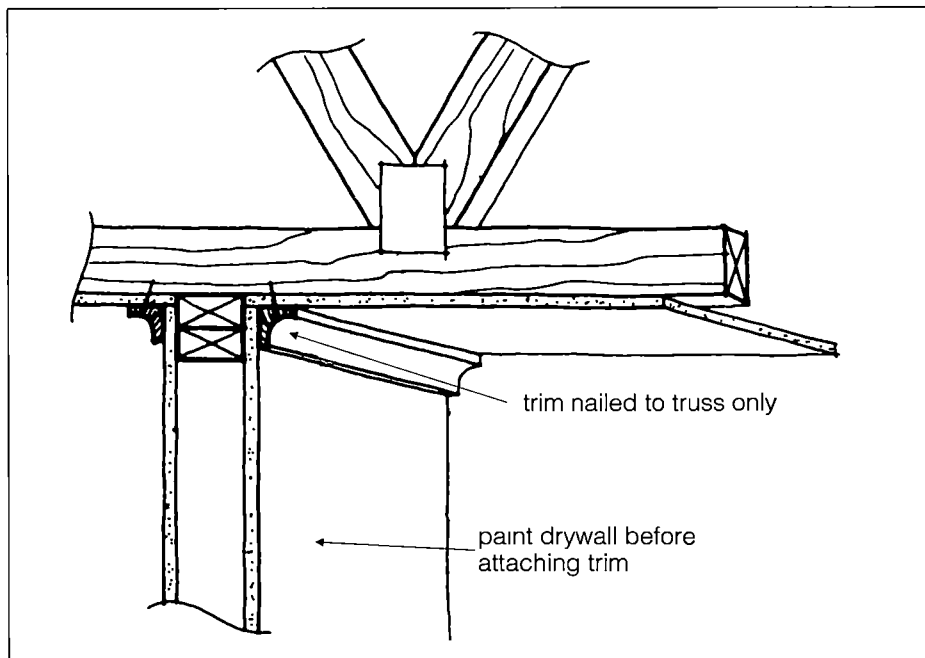

Fig. 12. Slip joint

## Problem

Other types of cracking

## Cause

Large-scale structural movement

*Racking, differential settlement, and shrinkage of major structural members will occur, especially at wall/wall and wall/ceiling intersections, and in multi-storied spaces such as stairwells.*

## Solutions

- Don't skimp on the foundation. This is the key to building stability.
- Use steel beams to replace built-up wood beams to reduce shrinkage effects.
- To reduce racking, there is a growing use of flat trusses for clear spans across foundations.
- Ensure that teleposts are adjustable and easily accessible.
- In multi-storied spaces, run sheets across the header, or use control joints covered with trim or mouldings.
- Strap ceilings with resilient channels.
- Float interior corners:
  - start ceiling nailing 175 mm (7") from wall.
  - start wall nailing 200 mm (8") from ceiling.
  - omit corner nailing for underlying board at wall/wall junction (*fig. 13*).

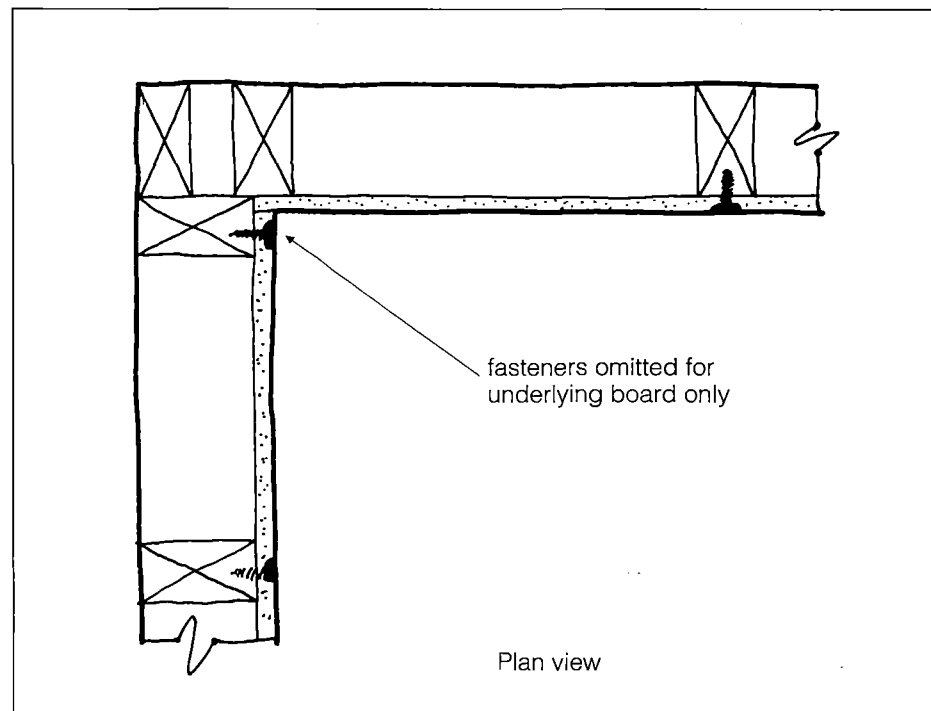

Fig. 13. Interior wall angle

- Manufacturers recommend using control to relief joints where partitions meet major structural elements (*fig. 14*).

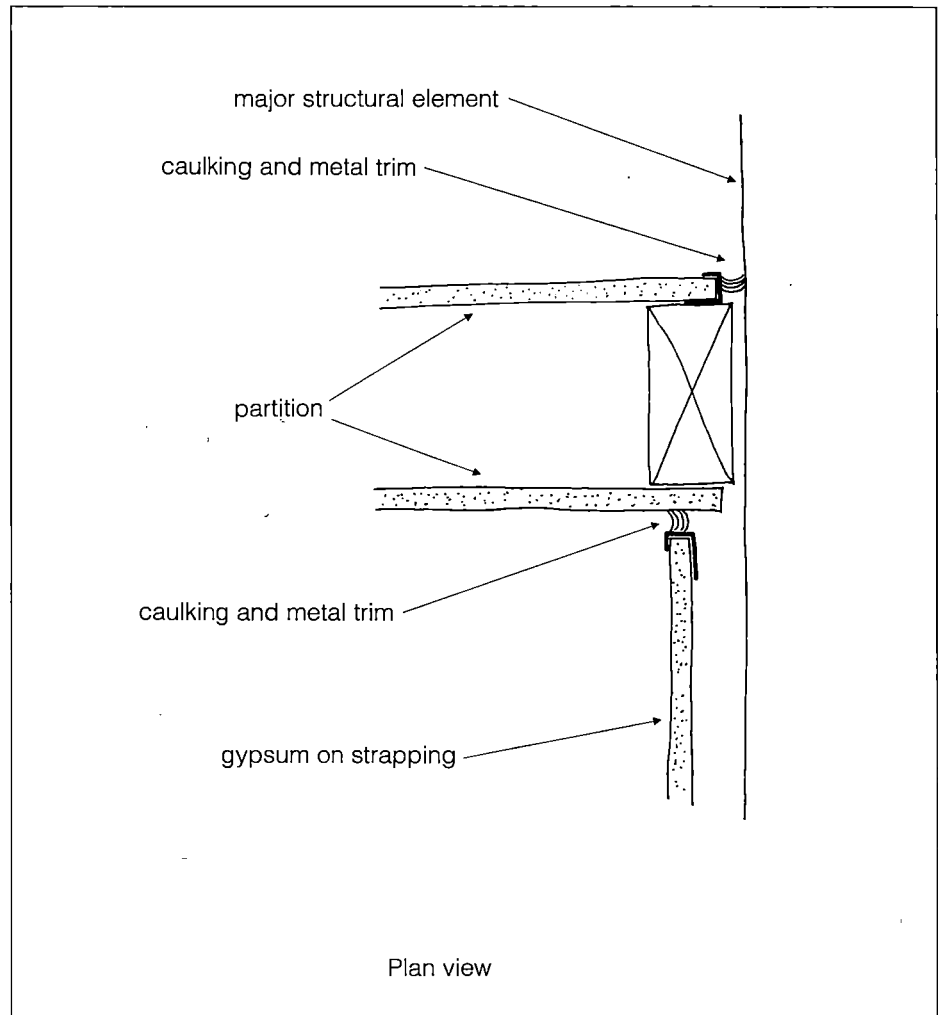

Fig. 14. Typical relief joints

**Cause**

Shrinkage of compound

**Solutions**

- To prevent surface cracking or crazing, do not overwater mix and avoid rapid drying in hot weather.
- To prevent angle cracking, avoid using too much compound in the apex of interior angles.

**Cause**

Cornerbead pulling away from framing

*Differential shrinkage, especially at beams or headers, can cause cracking along the cornerbead edge (fig. 15).*

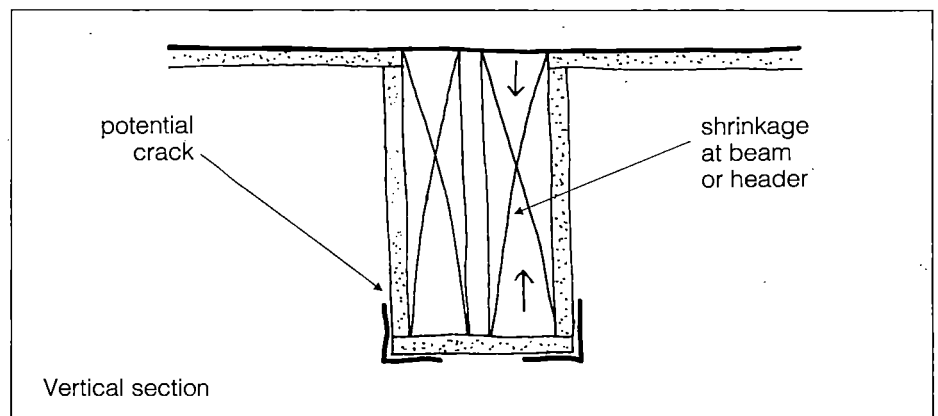

Fig. 15. Cornerbead cracking

## Problem: Other types of cracking

### Solutions

- Nail cornerbead at 100 mm (4") rather than at the usually recommended 150 mm (6"). Crimping alone may not be sufficient.
- Don't extend cornerbead right to the subfloor. Leave a 13 mm (1/2") gap
- Avoid flattening the cornerbead when fastening. Ensure a sufficiently high bead for adequate cover with finishing compound.
- In highly visible areas, such as the opening between living and dining rooms, some builders omit cornerbead and install wood trim.
- Some builders have reduced cornerbead cracking by using flexible cornerbead.

### Cause

Stresses at openings

### Solutions

- Avoid locating joints at the edge of the header (fig. 16).
- Provide adequate framing to absorb vibration from door and window operation. Cut jack studs accurately.
- Apply 150-200 mm (6"-8") lengths of joint tape diagonally to reinforce corners (fig. 16)
- Extend header beyond edge of the door opening.
- With metal framing, reinforce header/jamb intersections, or provide additional strut studs. Grout frames for heavy or oversized doors.

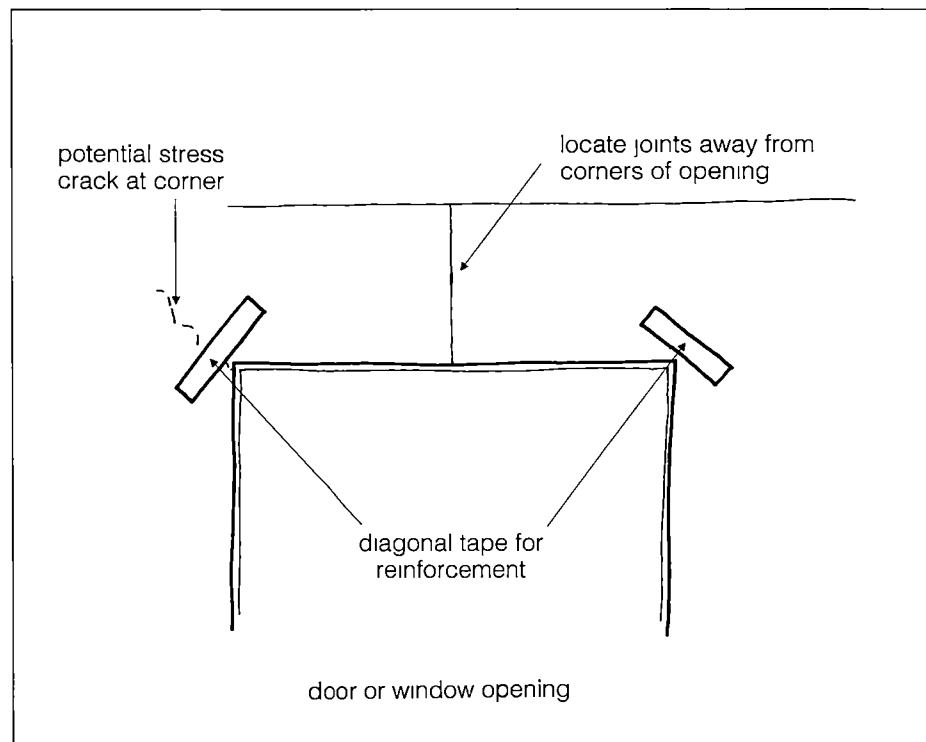

Fig. 16 Preventing stress cracks

### Cause

Inadequate corner support

### Solutions

- Avoid single-stud corners unless drywall clips are used. Provide adequate nailing surfaces, especially at interior corners (fig. 17).
- With metal studs, run drywall from the interior of the corners through to the outside face (fig. 18).

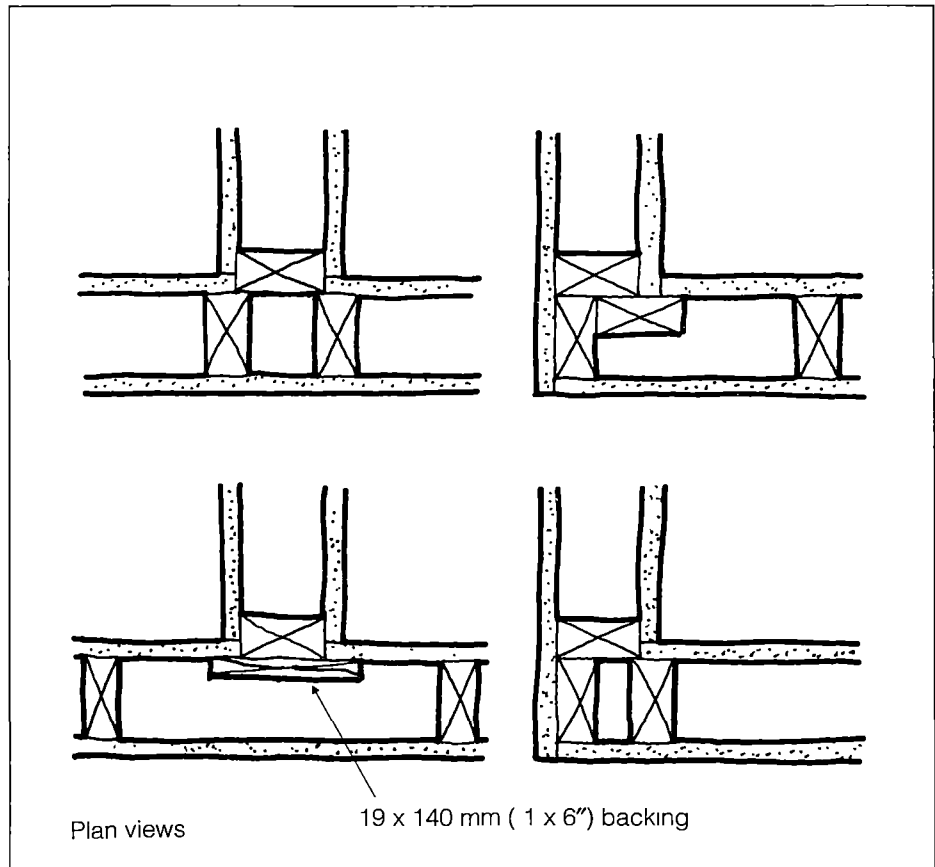

Fig. 17. Four alternatives for framing interior corners

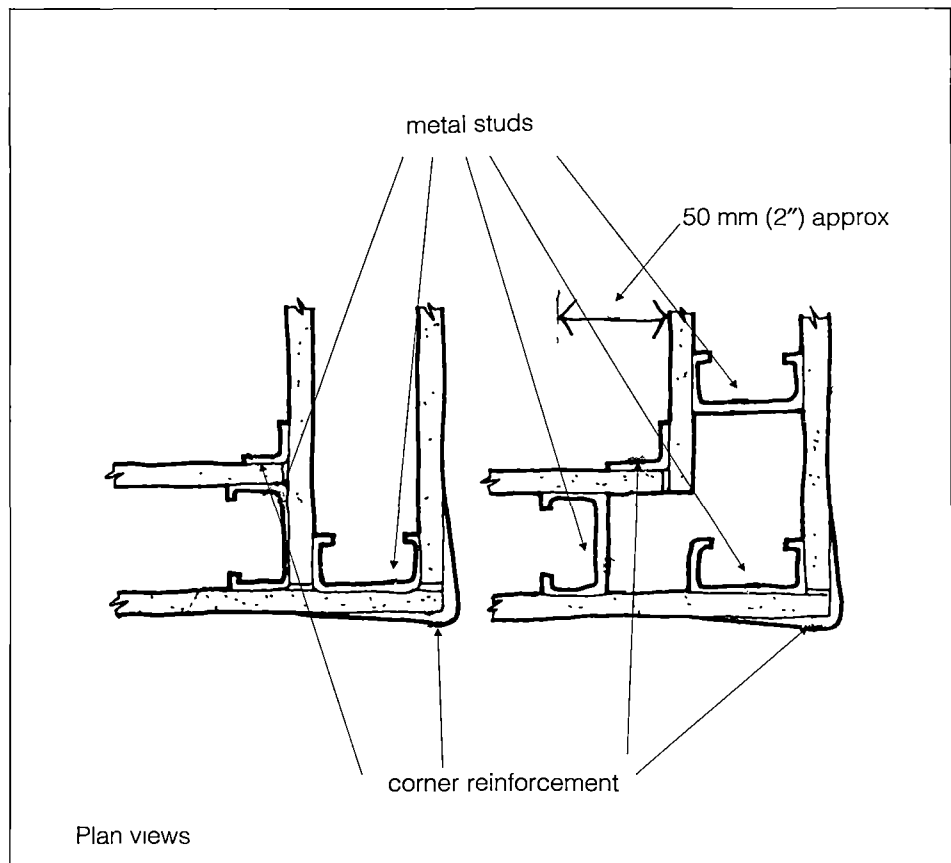

Fig 18. Interior corners with metal studs

**Problem** Sagging or wavy ceilings

**Cause** Excessive moisture and humidity  
*Texture spray too wet, high humidities and poor ventilation during construction, moisture in attic. Moisture absorption will soften the gypsum core.*

- Solutions**
- Apply alkyd sealer before texture spraying
  - Avoid overthinning spray mixture.
  - Ensure adequate ventilation during drying. Dehumidify if necessary.
  - Educate homeowner regarding the need to ventilate during periods or activities of high humidity (for example, steam-cleaning carpets).
  - Don't use water-resistant gypsum on ceilings — it has reduced resistance to sag.
  - Reduce the number of ceiling penetrations to cut down paths of moisture travel into the attic. Use more wall-mounted fixtures.

**Cause** Improper winter scheduling  
*When ceiling vapour barrier and drywall are applied and the building is heated, moisture may condense and freeze behind the board. When the ceiling is later insulated, the frost melts and the moisture is absorbed by the board (fig. 19).*

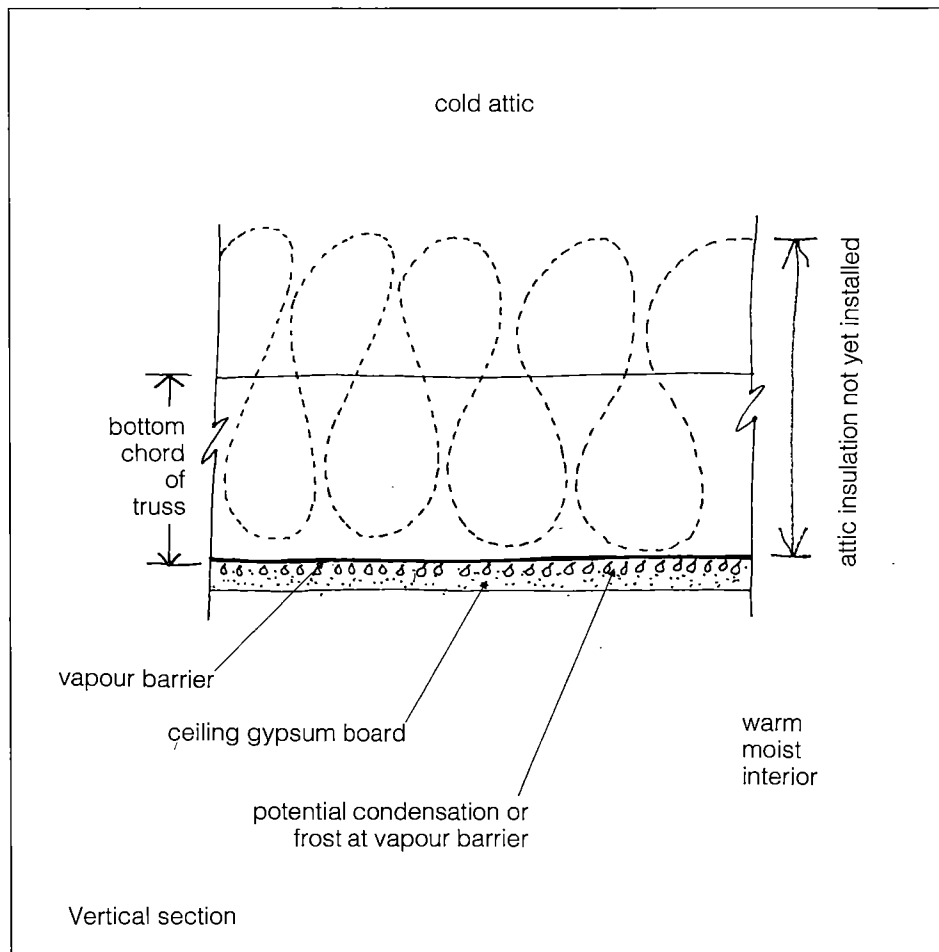

Fig. 19. Ceiling sag caused by improper scheduling

## **Problem: Sagging or wavy ceilings**

### **Solution**

- Insulate the ceiling on the same day boarding takes place. Alternatively, apply at least 50 mm (2") batts when the vapour barrier is installed, and add the balance of the insulation later.

### **Cause**

Overspanning

*Conventional construction practices may not accommodate the weight of thicker insulations.*

### **Solutions**

- Apply board perpendicular to ceiling framing.
- Use strapping or resilient channels at 400 mm (16") o.c. when roof trusses are spaced at 600 mm (24") o.c. This also creates a more even nailing surface for the board.
- Many builders use 16 mm (5/8") board on ceiling (*see table 1*). This allows a 70% increase in the weight of insulation that can be supported and provides a more rigid base for texture spray finishes.

**Table 1. Recommended Spacing of Ceiling Framing**

Board Thickness	Application	Maximum Joist or Truss Spacing	
		With Texture Spray	Without Texture Spray
12.7 mm (1/2")	Parallel to framing	Not recommended	400 mm (16")
	Perpendicular to framing	400 mm (16")	600 mm (24")
15.9 mm (5/8")	Parallel to framing	Not recommended	400 mm (16")
	Perpendicular to framing	600 mm (24")	600 mm (24")

---

**Problem** Visible joints, ridging and tape delamination

**Cause** Environmental conditions  
*Lack of sufficient heat or ventilation, especially during winter construction.*

- Solutions**
- Maintain a minimum temperature of 10°C (50°F) for two days before and four days after treatment. Loss of bond will occur if temperatures are too cold (*fig. 20*).
  - Make sure board is not damp and is free of frost.
  - Protect ready-mixed compounds from freezing.
  - Make sure there is adequate ventilation for drying. Temporary heating may cause high humidity levels. Some builders rent dehumidifiers.
  - Curing of the basement slab also releases moisture into the air. Allow the slab to cure, and remove any surface water before finishing the drywall, or delay pouring the slab until primer paint has been applied to the drywall. Provide ventilation.

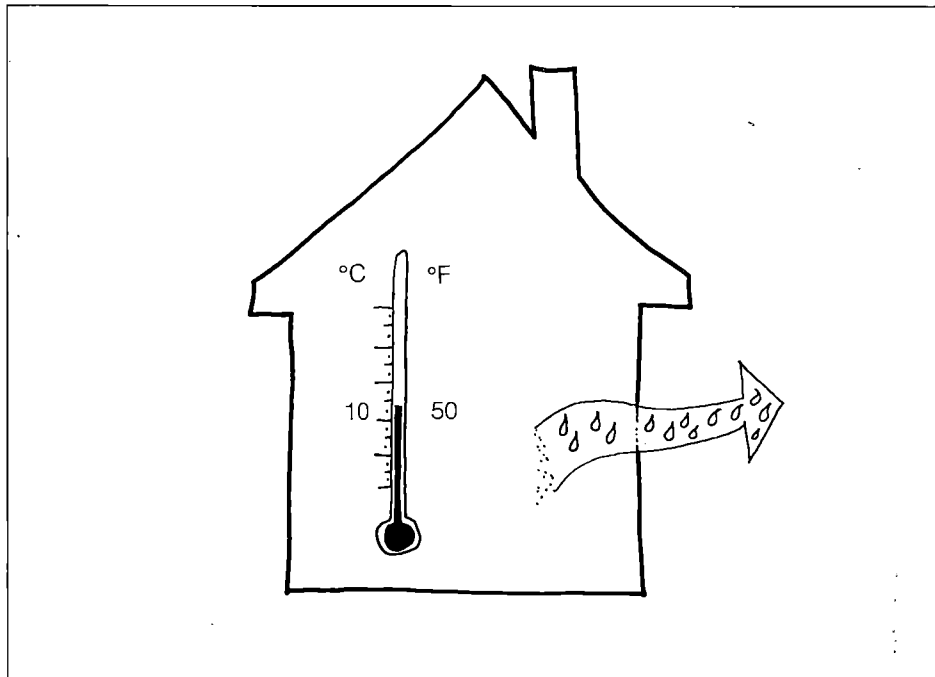

Fig. 20. Heat and ventilation requirements

**Cause** Damaged board edges

- Solutions**
- Schedule board delivery before installing windows, or leave key windows out for ease of delivery.
  - Avoid carrying board great distances or up tight stairways. Consult with the supplier on delivery preferences.
  - Stack board neatly in the centre of the rooms to protect board corners. Damaged ends are more susceptible to ridging.
  - Avoid temporary storage outside. Protect board from rain, wet snow and dampness.

**Problem: Visible joints, ridging and tape delamination**

**Cause**

Improper application of joint tape and compounds

**Solutions**

- Make sure the joint tape is completely embedded in the compound to prevent later bubbling.
- Avoid overwatering mix or using heavy fills.
- Follow the manufacturer's directions.
- Allow joint compounds to dry completely between coats.
- Paint only after compounds have fully dried to prevent joint darkening.
- Feather butt joints wider than edge joints (*fig. 21*).
- Avoid oversanding compound or sanding the board itself. This can result in "flashing" — different gloss textures on the joint and board.

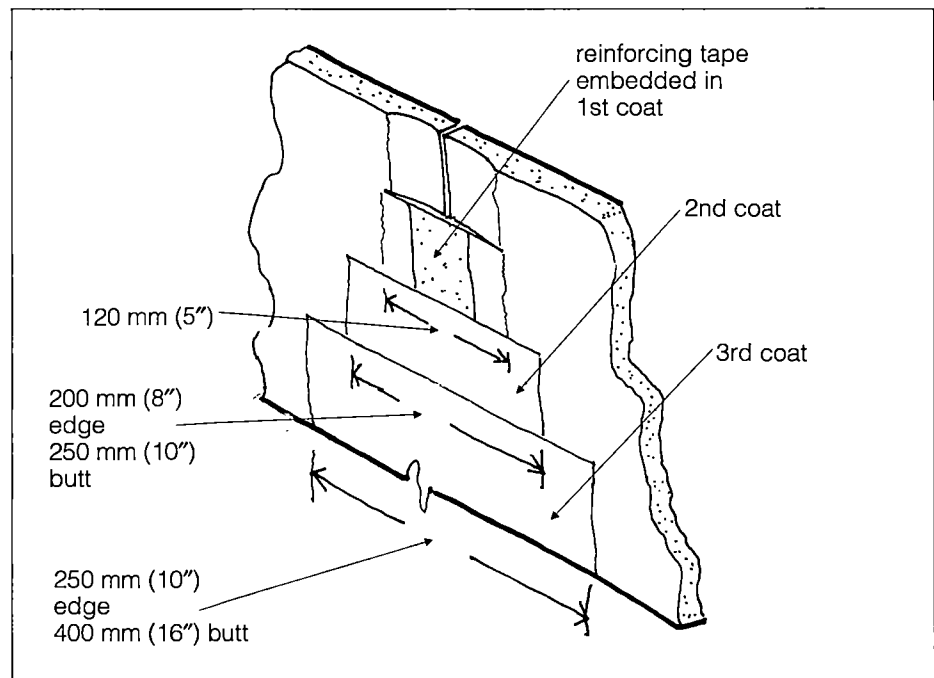

Fig. 21. Typical joint treatment

**Problem: Visible joints, ridging and tape delamination**

**Cause**

Lumber shrinkage

*Shrinkage at headers may cause ridging, especially at stairways (fig. 22). Ridging can also occur when studs and joists warp and twist (see also page 2).*

**Solutions**

- Float board across headers, fastening above and below, but not directly to the header itself. Alternatively, use horizontal control joints and conceal them with trim.
- Inspect framing prior to boarding. Straighten or replace warped studs. Use kiln-dried lumber if possible.
- Use longer studs where possible.

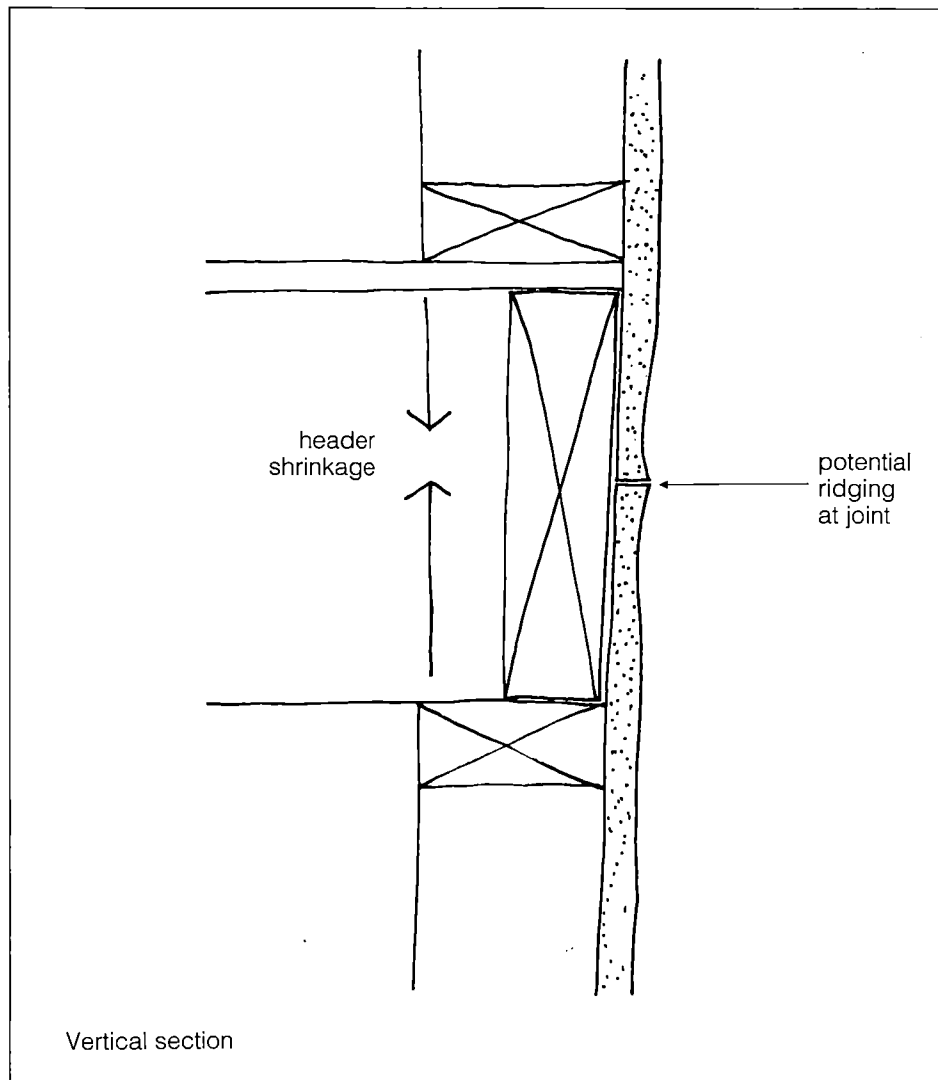

Fig. 22. Ridging at header

## **Problem: Visible joints, ridging and tape delamination**

### **Cause**

Improper board application

### **Solutions**

- Fasten boards from the centre outward to avoid putting board into compression. Don't force oversized panels into place.
- Where possible, align according to the direction of natural and artificial light to reduce the visibility of joints.
- Minimize butt joints by using the longest sheets possible.
- Install metal studs with all flanges facing the same direction and mount drywall in the direction opposite to flanges (*fig. 23*). This prevents flange deflection and later joint problems.

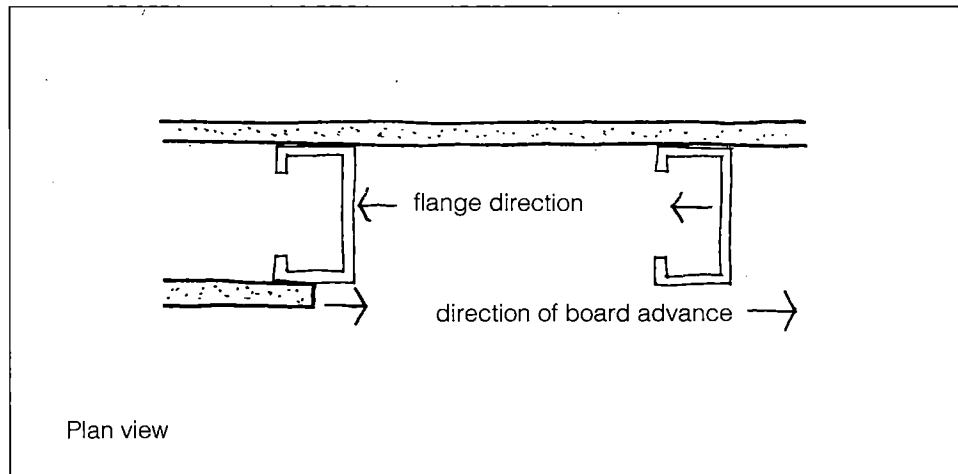

Fig. 23. Mounting direction

**Problem** Deterioration in high-moisture areas

**Cause** Excessive humidity and dampness in bathrooms, laundry areas, and exterior soffits

*Moisture absorption can cause expansion and powdering of the gypsum core, delamination of the paper face, and growth of mould and mildew.*

**Solutions**

- Use water-resistant gypsum board in damp areas. The National Building Code now requires "moisture-resistant backing" for ceramic tile. Regular board cannot be used.
- Allow 6 mm (1/4") space between the drywall and the surfaces of the tub, shower floor or return (fig. 24).
- To prevent problems at the bathtub, some builders use a cement-based board instead of gypsum board as an underlay for ceramic tile, or they install a fibreglass tub enclosure.
- In exterior applications such as soffits, use frequent control joints, and allow a 6 mm (1/4") space from all abutting vertical surfaces.
- Some builders strap bathroom walls to allow an airspace for improved drying.

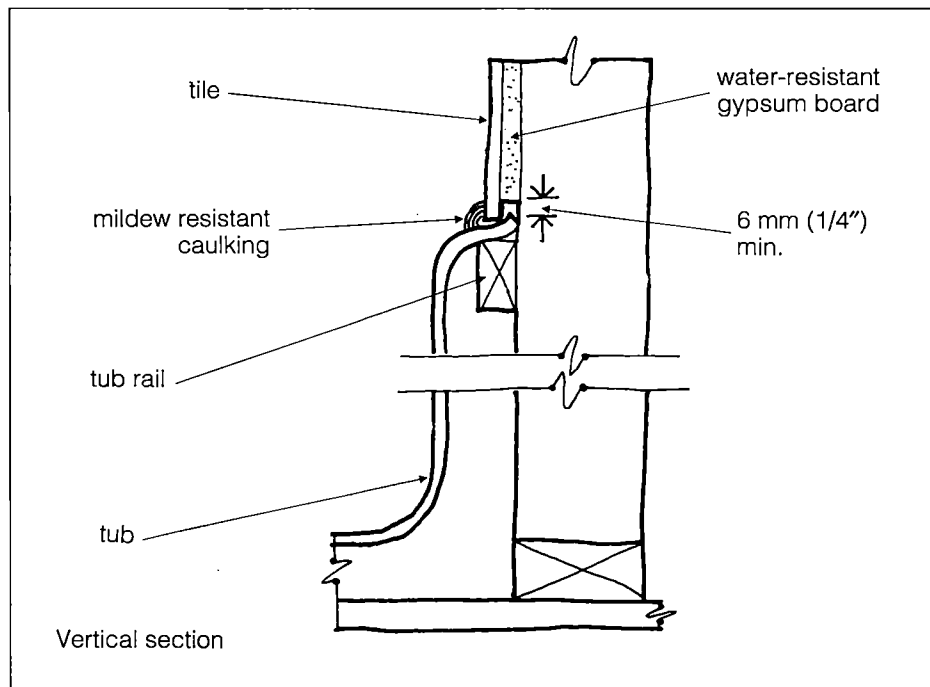

Fig. 24. Bathtub detail

# **Terms and Definitions**

## ***butt joint (end joint)***

the joint along the short dimension where the board is factory cut or jobsite cut and the core is exposed.

## ***edge joint (tapered joint)***

the joint along the paperbound long dimension where the board is recessed to accommodate tape and joint compound.

## ***angle cracking***

cracks at the interior intersection of walls or wall and ceiling.

## ***stress cracking (field cracking)***

diagonal crack originating at the corner of doors or windows, or at major structural elements.

## ***ridging***

outward bulging of the joint compound and tape, or of the board itself, caused by compression stresses.

## ***control, isolation, or relief joint***

predetermined opening between panels to relieve stress buildup caused by expansion or contraction.

## ***floating corner (floating angle)***

interior wall/ceiling and wall/wall intersections where fasteners have been reduced or omitted to make corner less rigid.

## ***truss uplift***

upward bowing of the roof trusses in winter, caused by the upper and lower chords being at different temperatures and having different moisture contents.

# Additional Reading

<b>Source</b>	<b>Publication</b>
Canada Mortgage and Housing Corporation 700 Montreal Road Ottawa, Ontario K1A 0P7 (613) 748-2000	<i>Canadian Wood-Frame House Construction</i> , 1988. NHA 5031
Canadian Standards Association 178 Rexdale Boulevard Toronto, Ontario M9W 1R3 (416) 747-2287	<i>Gypsum Board Application</i> , 1980 CSA A82.31-M1980
Canadian Gypsum Company Limited P.O. Box 4034 Terminal A 777 Bay Street Toronto, Ontario M5W 1K8 (905) 803-5600	<i>Drywall Construction Handbook</i> , 1980
Gypsum Association 1603 Orrington Avenue Evanston, Illinois U.S. 60201	<i>Recommended Specifications for the Application and Finishing of Gypsum Board</i> . GA-216-85
Forintek Canada Corporation 800 Montreal Road Ottawa, Ontario K1G 3Z5 (613) 744-0963	<i>Practical Solutions to the Truss Uplift Problem</i> , May 1987
Canadian Home Builders' Association 502 - 200 Elgin Street Ottawa, Ontario K2P 1L5 (613) 230-3060	<i>Special Bulletin: Report on Truss Uplift</i> (HUDAC, October 1980)
National Research Council Institute for Research in Construction Note Publications Section Ottawa, Ontario K1A 0R6 (613) 993-2463	<i>Upward Deflection of Wood Trusses in Winter</i> . Building Research Note 107, January 1976

For copies of the booklets listed below, send your order with cheque or money order made out to Canada Mortgage and Housing Corporation:

CMHC Publications  
Canada Mortgage and Housing Corporation  
700 Montreal Road  
Ottawa, Ontario  
K1A 0P7

Order publications by NHA number. Deduct 30 per cent on orders of 20 or more of any one publication. Add \$1 handling charge to each complete order.

**Builders' Series**

<i>Drywall Application</i>	NHA 5886 (\$1)
<i>Ventilation: Health &amp; Safety Issues</i>	NHA 5888 (\$1)
<i>Door and Window Installation</i>	NHA 5890 (\$1)
<i>Concrete Foundations</i>	NHA 5892 (\$1)
<i>Preserved Wood Foundations</i>	NHA 6006 (\$1)
<i>Moisture Problems</i>	NHA 6010 (\$1)
<i>Noise Control</i>	NHA 6012 (\$1)
<i>Radon Control in New Houses</i>	NHA 6067 (\$1)
<i>Indoor Air Quality</i>	NHA 6069 (\$1)
<i>Wood-Frame Construction Problems</i>	NHA 6072 (\$1)
<i>Siding Problems</i>	NHA 6074 (\$1)
<i>Roofing and Flashing Problems</i>	NHA 6076 (\$1)
<i>Guide to Residential Exhaust Systems</i>	NHA 6114 (\$1)

**Renovators' Series**

<i>Costing and Estimating</i>	NHA 6122 (\$1)
<i>Client Relations</i>	NHA 6124 (\$1)
<i>Renovators and the Law</i>	NHA 6126 (\$1)
<i>Marketing Strategies</i>	NHA 6128 (\$1)
<i>Performance of House Systems</i>	NHA 6130 (\$1)
<i>Project Manager: Communication</i>	NHA 6539 (\$1)

---

The material for this publication was developed in consultation with the Canadian Home Builders' Association for a series of seminars held across the country.