

FIRE AND SOUND

CONTROL IN WOOD-FRAME MULTI-FAMILY BUILDINGS

BEST PRACTICE GUIDE
BUILDING TECHNOLOGY

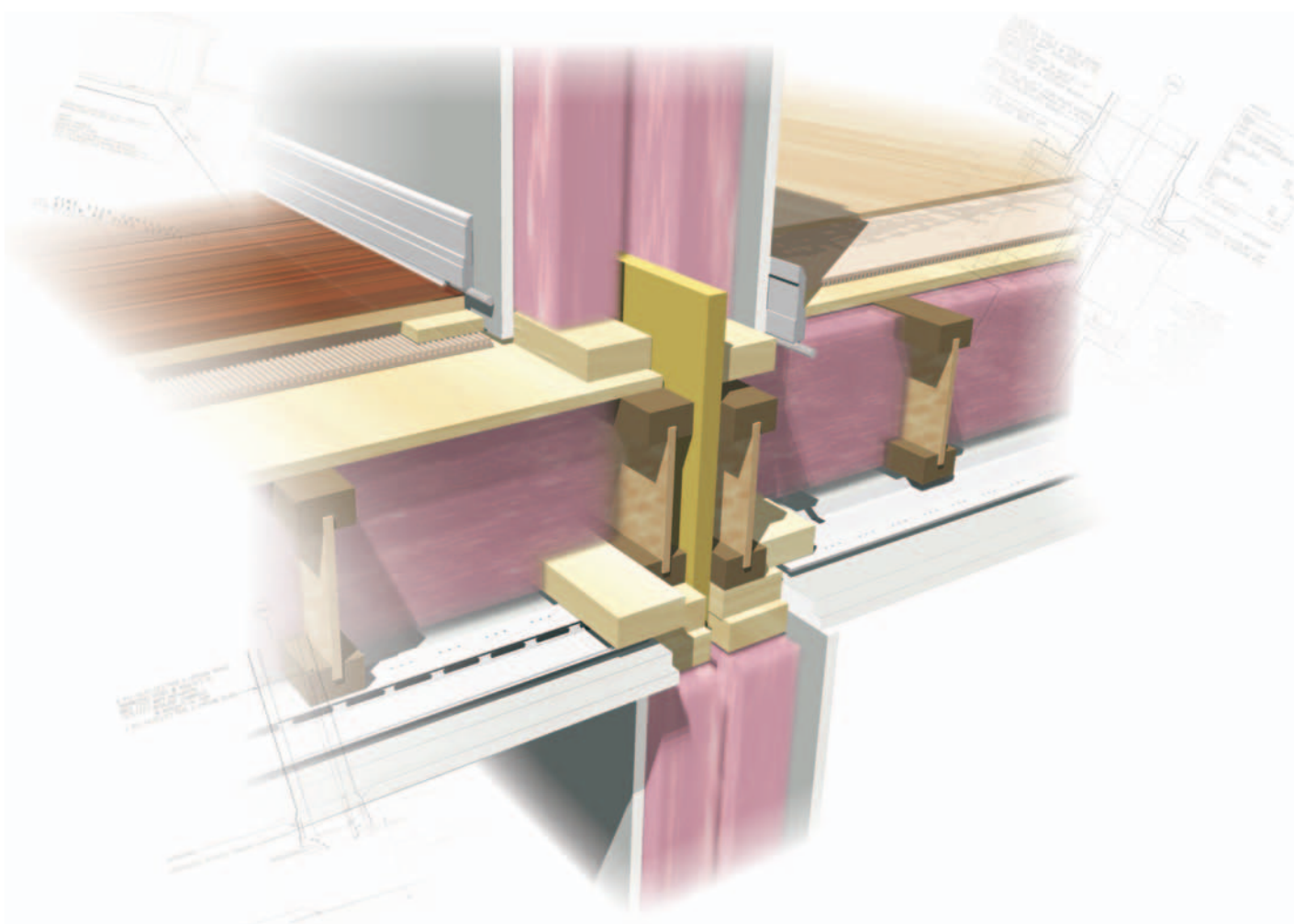

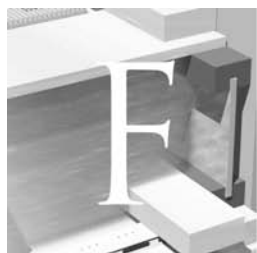

FIRE AND SOUND CONTROL IN WOOD-FRAME MULTI-FAMILY BUILDINGS

BEST PRACTICE GUIDE
BUILDING TECHNOLOGY

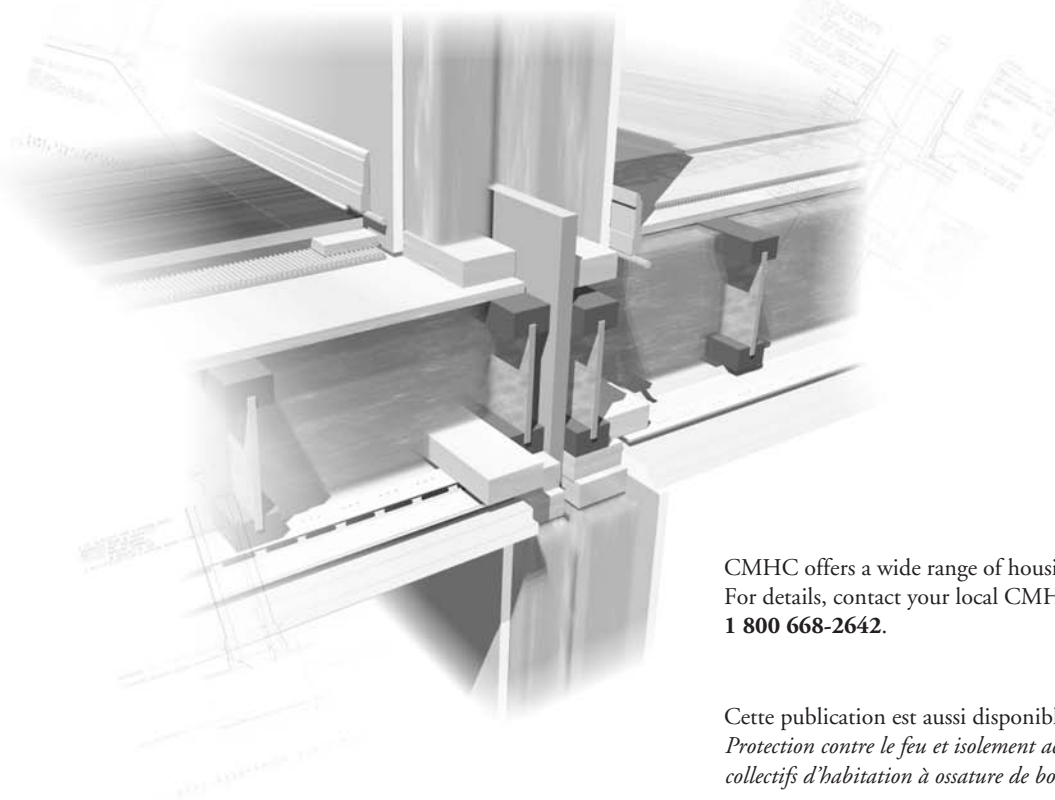

CMHC offers a wide range of housing-related information.
For details, contact your local CMHC office or call
1 800 668-2642.

Cette publication est aussi disponible en français sous le titre :
*Protection contre le feu et isolement acoustique des
collectifs d'habitation à ossature de bois—62943*

28-06-06

Canada 



National Research
Council Canada

Institute for
Research in
Construction

Conseil national
de recherches du Canada

Institut de
recherche en
construction



CMHC—HOME TO CANADIANS

Canada Mortgage and Housing Corporation (CMHC) has been Canada's national housing agency for over 60 years.

Together with other housing stakeholders, we help ensure that Canada maintains one of the best housing systems in the world. We are committed to helping Canadians access a wide choice of quality, affordable homes, while making vibrant, healthy communities and cities a reality across the country.

For more information, visit our website at www.cmhc.ca

You can also reach us by phone at 1 800 668-2642 or by fax at 1 800 245-9274.

Outside Canada call (613) 748-2003 or fax to (613) 748-2016.

Canada Mortgage and Housing Corporation supports the Government of Canada policy on access to information for people with disabilities. If you wish to obtain this publication in alternative formats, call 1 800 668-2642.

National Library of Canada cataloguing in publication data

Steering Committee for the Best Practice Guide, Fire and Sound Control
in Wood-Frame Multi-Family Buildings (Canada)

Fire and sound control in wood-frame multi-family buildings

(Best practice guide: building technology)

Issued also in French under title: Protection contre le feu et isolement
acoustique des collectifs d'habitation à ossature de bois.

Includes a CD-ROM with CAD drawings.

Includes bibliographical references.

On cover : Institute for Research in Construction.

ISBN 0-660-18822-8

Cat. no. NH15-132/4-2002E

1. Wooden-frame buildings—Fires and fire prevention—Handbooks, manuals,
etc.
2. Building, Wooden—Fires and fire prevention—Handbooks, manuals, etc.
3. Architectural acoustics—Handbooks, manuals, etc.
 - I. Institute for Research in Construction (Canada)
 - II. Canada Mortgage and Housing Corporation.
 - III. Series.

TH4818.W6F57 2002

694'.2

C2002-980258-X

Reprinted 2004,2006

Revised 2006

© 2003, Canada Mortgage and Housing Corporation. All rights reserved. No portion of this book may be reproduced, stored in a retrieval system or transmitted in any form or by any means, mechanical, electronic, photocopying, recording or otherwise without the prior written permission of Canada Mortgage and Housing Corporation. Without limiting the generality of the foregoing no portion of this book may be translated from English into any other language without the prior written permission of Canada Mortgage and Housing Corporation.

Printed in Canada
Produced by CMHC

FOREWORD

Canada Mortgage and Housing Canada Mortgage and Housing Corporation, the federal government's housing agency, is responsible for administering the *National Housing Act*.

This legislation is designed to aid in the improvement of housing and living conditions in Canada. As a result, the corporation has interests in all aspects of housing and urban growth and development.

Under Part IX of this Act, the Government of Canada provides funds to CMHC to conduct research into the social, economic, and technical aspects of housing and related fields, and to undertake the publishing and distribution of the results of this research. CMHC therefore has a statutory responsibility to make widely available information that may be useful in the improvement of housing and living conditions.

This publication is one of the many items of information published by CMHC with the assistance of federal funds.

DISCLAIMER

The analysis, interpretations, and recommendations are those of the consultants and do not necessarily reflect the views of CMHC or those divisions of the corporation that assisted in preparation and publication.

Care has been taken to review the research summarized in this Guide, but no attempt has been made to replicate or check experimental results or validate computer programs. Neither the authors nor CMHC warrant or assume any liability for the accuracy or completeness of the text, drawings, or accompanying diskette, or their fitness for any particular purpose. It is the responsibility of the user to apply professional knowledge in the use of the information contained in these drawings, specifications, and texts, to consult original sources, or when appropriate, to consult an architect or professional engineer.

STEERING COMMITTEE FOR THE BEST PRACTICE GUIDE, FIRE AND SOUND CONTROL IN WOOD- FRAME MULTI-FAMILY BUILDINGS

John Evans
Roxul Inc.,
551 Harrop Drive,
Milton, Ontario

Susan Friedrich, BES, B.Arch, OAA
Susan Friedrich Architect Inc.
643 St. Clair Ave. W.,
Toronto, Ontario

Rod McPhee, CET, CIP
Canadian Wood Council
Suite 210, 1400 Blair Place,
Ottawa, Ontario

Ann Reid
Buildings Branch
*Ontario Ministry of Municipal Affairs
and Housing*
2nd Floor, 777 Bay Street,
Toronto, Ontario

Ken Richardson, P.Eng., FSFPE
Ken Richardson Fire Technologies Inc.
891 Beauclaire Drive,
Gloucester, Ontario

Pamela Shinkoda, P.Eng.
Westroc Inc.
2424 Lakeshore Rd. W.,
Mississauga, Ontario

Gordon Spratt, M.Eng., P.Eng.
Gordon Spratt & Associates
2348 Yukon Street,
Vancouver, BC

Gary Sturgeon, P.Eng.
Masonry Canada
210 Chinook Dr.,
Cochrane, Alberta

Alf Warnock, Ph.D.
National Research Council of Canada
M-59 Montreal Road,
Ottawa, Ontario

Keith Wilson, M.Sc.
Owens Corning Canada
42 Johnson Street,
Orillia, Ontario

I / INTRODUCTION

Scope of this Guide	1-1
Authority having jurisdiction and codes	1-4

2 / FIRE AND SOUND CONTROL BASICS

Introduction	2-1
Controlling fire in buildings	2-1
Goals for fire control in multi-family buildings	2-2
Fire control by construction	2-5
Fire stopping	2-7
The physics of sound	2-7
Behaviour of sound in buildings	2-10
Steps to controlling sound transmission	2-12
Barriers to the passage of sound	2-12
Heavy building materials	2-13
Using sound-absorbing materials	2-14
Ideal assemblies	2-14

3 / FIRE-RESISTANCE RATINGS AND SOUND TRANSMISSION CLASSES

Introduction	3-1
Controlling fire spread with wall and floor assemblies	3-1
Fire separations	3-5
NBCC and fire separations	3-6
Sound testing of walls and floors	3-8
Sound control and the National Building Code of Canada	3-12
Best practices and minimum ratings for sound control	3-15

4 / INTERIOR WALL ASSEMBLIES

Introduction	4-1
Controlling fire with wall assemblies	4-1
Fire-resistance of framed wall assemblies	4-2
Fire-resistance of concrete-block walls	4-12
Ratings by calculation	4-13
Impact of integrating services on fire-resistance	4-14
Sound control and wall assemblies	4-15
Sound control with framed walls	4-16
Sound control with masonry and concrete walls	4-16
Integrating services to avoid unwanted sound	4-23
Assembling and integrating components to avoid unwanted sound	4-26

5 / FLOOR ASSEMBLIES BETWEEN DWELLING UNITS

Introduction	5-1
Unrated floor assemblies	5-10
Impact of integrating services in floors on fire-resistance	5-16
Limiting fire spread at wall-floor intersections	5-17
Sound control in floors	5-21
Sound control for joist and truss floors	5-22
Reducing impact noise	5-23
Reducing flanking noise and other unintended sound transmission	5-25

6 / WALL AND FLOOR ASSEMBLY DETAILS

Introduction	6-1
--------------	-----

FIGURES

Figure 1.1: Dwelling units clustered horizontally and vertically	1-1
Figure 2.1: Managing fire	2-3
Figure 2.2: Apartment suite compartmentation	2-5
Figure 2.3: Fire stopping	2-8
Figure 2.4: Flanking sound transmission	2-12
Figure 2.5: Heavy materials transmit less sound	2-13
Figure 2.6: Sound-absorbing materials dissipate sound energy	2-14
Figure 2.7: The ideal assembly	2-15
Figure 2.8: Effects of wall cavity and sound-absorbing materials on transmission loss	2-15
Figure 3.1: Typical fire exposures	3-2
Figure 3.2: Example of fire-test furnace for wall assemblies	3-3
Figure 3.3: Measuring sound transmission loss in the laboratory	3-8
Figure 3.4: Transmission loss for common construction materials	3-8
Figure 3.5: Fitting the STC contour to transmission loss data	3-10
Figure 3.6: Floor tapping machines used for impact insulation ratings	3-11
Figure 3.7: Measuring Impact Insulation Class in floor systems	3-11
Figure 3.8: Fitting the IIC contour to floor assembly test data	3-12
Figure 3.9: Sound performance of floating floor assemblies	3-16
Figure 4.1: Ratings for wall assemblies	4-3 to 4-8
Figure 4.2: Nail and screw fastening for gypsum board	4-11
Figure 4.3: Staggered studs vs. double studs	4-17
Figure 4.4: Estimating STC improvement for block walls	4-20

Figure 4.5:	Debris between wythes of concrete blocks	4-22
Figure 4.6:	Double-stud construction and the location of electrical outlet boxes	4-24
Figure 4.7:	Electrical and plumbing services reduce noise and occupant discomfort	4-25
Figure 4.8:	Penetration of sound through cracks in a framed wall	4-26
Figure 4.9:	Sound leak caused by debris under the sole plate	4-27
Figure 4.10:	Application of sealant to prevent sound leaks	4-27
Figure 4.11:	Sound transmission and double cavities	4-28
Figure 4.12:	Eliminating flanking transmission path in walls	4-29
Figure 4.13:	Gypsum board application	4-30
Figure 5.1:	Ratings for floor assemblies	5-9
Figure 5.2:	Fire-resistance ratings for floors in multi-storey, stacked dwelling units	5-11 to 5-15
Figure 5.3:	Thermal protection above a duct	5-17
Figure 5.4:	Test assembly for fire stop research	5-18
Figure 5.5:	Using semi-rigid insulation board firestopping	5-19
Figure 5.6:	Testing air cavity widths	5-20
Figure 5.7:	Effects of concrete topping on a wood joist floor assembly	5-23
Figure 5.8:	Floating floors	5-24
Figure 5.9:	Short-circuiting resilient layers in floor assemblies	5-25
Figure 5.10:	Incorrect use of resilient channels in floor assemblies	5-26
Figure 5.11:	Controlling flanking noise	5-26
Figure 5.12:	Eliminating flanking paths in wood-frame floors	5-27
Figure 5.13:	Eliminating vertical flanking paths	5-28
Figure 5.14:	Flanking paths along concrete floor toppings	5-28

LIST OF TABLES

Table 2.1:	Sound pressure levels for common sound	2-10
Table 3.1:	Required fire-resistance in wood-frame multi-family buildings	3-7
Table 3.2:	The audibility of speech and music through walls of various STC ratings	3-9
Table 3.3:	ASTM tests used in building acoustics	3-14
Table 3.4:	Minimum recommended STC and IIC for occupant satisfaction for various structural elements	3-15
Table 4.1:	Time assigned to wallboard membranes on fire-exposed side (from NBCC, 1995)	4-9

Table 4.2:	Time assigned for contribution of wood-frame (from NBCC, 1995)	4-9
Table 4.3:	Fire-resistance and monolithic load-bearing and non-load-bearing concrete wall thicknesses in millimetres (from NBCC, 1995)	4-14
Table 4.4:	Test-Derived STC ratings for frame walls	4-18
Table 4.5:	Typical STC ratings for single-wythe concrete-block walls with hollow, sealed units	4-19
Table 4.6:	STC ratings for structurally isolated, block-cavity walls	4-22
Table 4.7:	STC for solid-concrete construction	4-23
Table 5.1:	Time assigned to membranes on fire-exposed side (from NBCC, 1995)	5-4
Table 5.2:	Time assigned for contribution of floor frame	5-4
Table 5.3:	Minimum fastener penetrations for membrane protection on wood-frame, mm (in.) (from NBCC, 1995)	5-5
Table 5.4:	Flooring membranes (from Table D-2.3.5, NBCC, 1995)	5-5
Table 5.5:	Fire-resistance rating for ceiling membranes (from Table D-2.3.12, NBCC, 1995)	5-7
Table 5.6:	STC and IIC ratings for floors	5-22

DETAILS

Detail 1:	Non-loadbearing party wall	6-5
Detail 2:	Party wall at floating floor	6-7
Detail 3:	Loadbearing party wall or partition	6-9
Detail 4:	Double-stud party wall	6-11
Detail 5:	Double-stud party wall—unrated floors	6-13
Detail 6:	Double-stud party wall at offset floors	6-15
Detail 7:	Double-stud wall plan at exterior wall	6-17
Detail 8:	Double-stud wall plan at corridor	6-19
Detail 9:	Fire stop ceiling bulkhead	6-21
Detail 10:	Concrete masonry unit wall assembly	6-23
Detail 11:	Stair as a fire separation	6-25
Detail 12:	Electrical outlets plan	6-27

SCOPE OF THIS GUIDE

Builders and designers strive to create living spaces that are safe, healthy, durable, and comfortable—free from unwanted external noises and sounds, and the rapid spread of fire. Buildings that house a number of families or dwelling units tend to demand more attention in this regard than single-family buildings. Unless steps are taken in the design and construction of the building, sound and fire can easily travel from one dwelling unit to another, affecting both neighbouring occupants and property.

In recent years, wood-frame construction has been used much more frequently for multi-family buildings. These buildings, seldom more than three storeys in height but permitted to extend to four storeys, can include any number of dwelling units clustered both horizontally and vertically as shown in Figure 1.1. While wood-frame buildings are often limited in terms of total building area, firewalls are sometimes used in the construction of larger structures to avoid the need for non-combustible construction. In all cases, fire spread and sound transmission are suitably controlled to meet all safety standards. In general, the very details that provide for fire and sound control also enhance comfort, energy efficiency and durability.

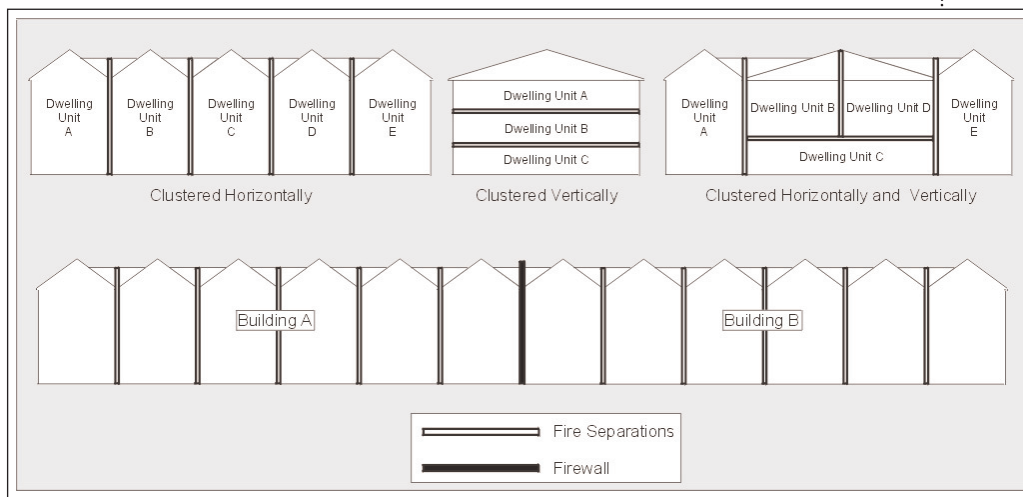

Figure 1.1: Dwelling units clustered horizontally and vertically

This *Guide* shows how the spread of fire and the transmission of sound between dwelling units can be controlled in wood-frame, multi-family buildings. It focuses on how the spread of fire and transmission of sound can be controlled through the design and construction of the walls and floors that separate one dwelling unit from another in a building. It relies on the results of research performed by National Research Council of Canada/Institute for Research in Construction (NRC/IRC)¹ and consultants for Canada Mortgage and Housing Corporation (CMHC), among others. This research will be highlighted

¹ Most of the information from NRC/IRC came from a project supported by an industry consortia including Canada Mortgage and Housing Corporation, Canadian Sheet Steel Building Institute, Cellulose Insulation Manufacturers of Canada, Forintek Canada Corp., Gypsum Manufacturers of Canada, Owens Corning Fiberglas Canada Inc., Roxul Inc., Canadian Home Builders' Association, and the National Research Council of Canada/Institute for Research in Construction.

throughout the publication as the basis for the best practices that are presented. It should be carefully noted that raw test data has been included to illustrate issues but may not be accepted by local authorities having jurisdiction as the basis for design.

It should be noted that while this publication attempts to present the state of the art, it does not address the many outstanding issues yet unresolved within the research community. These, in the fullness of time, will be researched and resolved and result in new practices.

The scope of the *Guide* has been limited to interior walls and floors, and does not include any discussion of roofs or exterior walls. In no way should this diminish the importance of appropriately designing these elements. The *Guide* is also confined to buildings that meet the size and height limitations imposed on buildings that use wood-frame construction. Reference will be made throughout the *Guide* to the requirements of the National Building Code of Canada (NBCC). It should be clear, however, that this publication is not a guide to the building code; rather, as a collection of best practices it summarizes the latest research and presents it in a fashion that can be applied in practice to design and construction. Commentaries are available from the National Research Council of Canada (NRCC) that discuss the minimum fire safety requirements of the NBCC.^{2,3,4} Also, the Canadian Wood Council has two publications, *Fire Safety in Buildings* and *Fire Safety in Residential Buildings* that provide additional information on fire safety and describe how wood-frame construction can be designed to meet the minimum requirements in the NBCC.

MULTI-FAMILY WOOD-FRAME BUILDINGS

Wood-frame buildings typically utilize a light wooden structural frame for wall, floor and roof assemblies. Walls are typically framed with studs while floors are built as platforms (platform framing). Platform construction is by far the most common approach used in Canada today. Floor members can be solid sawn lumber, wood I-joists or trusses with truss webs of wood or steel. Wood-frame buildings at times also make use of components not necessarily made of wood. Today's wood-frame buildings can include demising walls that make use of concrete-block construction, for instance. These variations are not uncommon and typically are a response to local practices and material costs.

With attention to design and detailing, wood-frame assemblies are able to more than adequately control fire and sound in multi-family building. This *Guide*, while focusing on construction made of wood, also addresses the more common variations of wall and floor assemblies that utilize components made of masonry or concrete. While the details that are presented and the associated discussion focuses on wood-frame construction, this should not imply in any way that alternative non-wood-frame approaches are less desirable or sub-optimal. In fact, non-wood-frame approaches may represent the best solution to certain circumstances.

² "User's Guide—NBC 1995 Fire Protection, Occupant Safety and Accessibility (Part 3)," NRCC, Ottawa, 1997.

³ "Fire Safety Design in Buildings," Canadian Wood Council, Ottawa, 1996.

⁴ "Fire Safety in Residential Buildings, Building Performance Series No. 2," Canadian Wood Council, Ottawa, 2000.

FIRE AND SOUND CONTROL IN MULTI-FAMILY BUILDINGS

Most fires in suites or other compartments in residential buildings typically do not grow to a sufficient size to affect the structural integrity of wall or floor assemblies. Fires that do grow can impose major thermal stress on wall and floor assemblies unless the building is protected by an automatic fire suppression system. Fires can spread through wall and floor assemblies from one dwelling unit to an adjacent dwelling unit, exposing neighbouring occupants and property to fire and smoke.

Unwanted sound can also travel from one unit into another and although not causing any physical damage can seriously impair the personal enjoyment of a private space, at times adversely affecting occupant health and comfort.

Controlling the spread of fire and the transmission of sound in multi-family buildings demands the adoption of specific measures in the design and construction of these buildings. Fire spread and sound transmission in multi-family buildings can be controlled by appropriately tailoring the construction to the intended use of the building. Wall and floor assemblies can be selected based on their ability to resist fire spread (rated as a fire-resistance rating) and to resist sound transmission (rated as sound transmission class and impact insulation class). These important characteristics can be used to ensure buildings provide adequate levels of protection against the spread of fire and transmission of unwanted sound.

This *Guide* shows how wall and floor assemblies in wood-frame, multi-family buildings can be designed to reduce the likelihood of fire spread and reduce the level of sound transmission.

It is unreasonable to expect conventional wall and floor systems to provide complete protection. For instance, some types of day-to-day sound generated within a dwelling unit, for example low frequency sound from home theatre systems, is very difficult to control using conventional details. Constructing systems that provide complete protection would result in buildings very few could afford. Nonetheless, building details using a variety of materials and systems are available that can provide an acceptable measure of protection, even for low frequency and impact sounds. The builder and designer are encouraged to examine the full range of alternatives that might be available.

Specifically, this *Guide* examines the fire-resistance and sound transmission characteristics of typical wall and floor assemblies found in wood-frame multi-family buildings and factors in design and construction that affect their fire-resistance and sound transmission ratings. This *Guide* outlines:

- Background information on how fire and sound moves from one dwelling unit to another in multi-family buildings.
- The standards that establish the requirements for assemblies that provide fire and sound separations between dwelling units.
- Specific fire-resistance and sound transmission control measures for wall and floor assemblies.
- The effects of services and other special conditions on fire and sound performance of wall and floor assemblies.
- Specific details for the construction of wall and floor assemblies.

AUTHORITY HAVING JURISDICTION AND CODES

The fire-resistance and sound transmission characteristics of a wall or a floor assembly are typically rated by standard tests of the assembly. The NBCC references the applicable test standards to be used for determining both the fire-resistance rating and sound transmission rating of assemblies. In both cases, the standardized test conditions are intended to represent a reasonable average of likely exposure conditions for the assembly in real life. With this approach, builders and designers can choose from a number of alternatives given their fire-resistance and sound attenuation characteristics.

The NBCC includes details on specific assemblies tested by the NRCC. The values assigned to the different wall and floor assemblies can be used where a proposed assembly matches the specific listed assembly in all essential elements. This is an important point since differences may adversely affect expected performance. Nonetheless, some minor variance in ratings will always exist between actual field performance and laboratory rated performance. Historically, ratings listed by the NBCC have been accepted by provincial and local authorities.

It should be clear that ultimately the local authority having jurisdiction will determine whether an assembly is acceptable in meeting the requirements of the local building code. In addition to the listings tabulated in the NBCC, assemblies that are supported by test reports, either field or laboratory, and which document the test results for assemblies identical to those to be constructed are also generally considered acceptable. In some cases, an estimate by a fire safety or acoustical engineer could be used as the basis for accepting an assembly. It is always prudent to consult the authority having jurisdiction where any question might exist about the acceptability of an assembly or detail.

INTRODUCTION

Developing design strategies to control the spread of fire and sound transmission should begin by developing a basic understanding of how fire begins and spreads and how sound moves through the fabric of the building. Understanding some of the science that is the basis for how assemblies are evaluated and rated will help the designer and builder to select those assemblies that are best suited to a building and its occupants. While, in many cases, the actual physical mechanisms involved in the spread of fire and the transmission of sound can be quite complex, it is possible to frame the discussion in easy-to-understand terms that will enable the design and construction of healthy and safe buildings.

This chapter reviews the fire and sound control basics. It introduces terminology that will be encountered throughout the *Guide*. The chapter provides an overview of the fire control strategies that exist and those that are most useful to the designer and builder. Finally, it explains how construction can be used to control the spread of fire and the transmission of sound, identifying the specific characteristics of assemblies that provide these important functions.

CONTROLLING FIRE IN BUILDINGS

Statistics show that residential buildings account for 40 per cent of all fires and almost 80 per cent of all fire deaths.⁵ One-third of these deaths occur in multi-family buildings (MFBs). In an attempt to reduce the loss of life from fire, Canadian building codes require designers and builders of multi-family buildings to consider the potential for fire ignition, fire growth and fire spread as well as approaches to early warning and suppression. The discussion below identifies background information that can be used when designing and constructing wood-frame, multi-family buildings to provide adequate levels of fire performance.

IGNITION

In residential buildings there are many possible sources of ignition. Canadian statistics indicate that the most common sources are smoking (20 per cent), electrical (19 per cent) and cooking equipment (11 per cent).⁶ The most common materials first ignited are upholstered furniture and bedding, both brought in by occupants after the building construction is completed. Obviously, a designer or builder has little control over such ignition scenarios. In most cases, ignition control strategies, identified by building codes, are limited to maintaining necessary clearances from fuel burning appliances and equipment and ensuring that electrical and mechanical systems are properly installed.

⁵ "Fire Loses in Canada, Annual Report 1995," Council of Canadian Fire Marshals and Fire Commissioners, Human Resources Development Canada, Hull, QC.

⁶ *ibid.*

FIRE GROWTH

The NBCC contains requirements for residential buildings that are intended to reduce the probability that fire will grow and spread in a building. This primarily involves:

- Limits that are placed on the surface flammability of interior finishes.
- The need for automatic sprinkler systems to suppress or control fire.
- In some cases, the use of non-combustible construction.

In general, the use of non-combustible floor, wall and roof assemblies, including interior finish materials, has a limited impact on fire growth, and often represents a capital cost upgrade. Automatic sprinkler systems are very effective, especially in residential occupancies, in reducing the potential for fire growth, but also have cost implications. For four storey, multi-family buildings, the NBCC mandates automatic sprinkler protection whether the construction is combustible or non-combustible. Multi-family buildings over four storeys in height must be of non-combustible construction and be sprinklered.

FIRE SPREAD

Unlike ignition and fire growth, fire spread is an area where designers and builders can influence the level of control that is built into a building. The spread of fire from one dwelling to another can be controlled by adopting appropriate fire resistant assemblies. In fact, wall and floor construction designed to control fire spread is basic to most passive fire protection in MFBs. Current practice to control the spread of fire relies on the use of fire-rated floor and wall assemblies that form an effective barrier to the movement of fire from one dwelling to another. These assemblies, often referred to as fire separations, come in a variety of configurations and make use of a full range of construction materials.

GOALS FOR FIRE CONTROL IN MULTI-FAMILY BUILDINGS

Understanding the goals of fire control and how they can be met is the first step in selecting appropriate assemblies that can restrict the spread of fire from one space to another. The primary goal for fire control in multi-family buildings is to provide safety for occupants. Related to this are the secondary goals of protection of property, preventing the loss of function and minimizing the damage caused to the environment.

To achieve these goals, fire safety strategies for the design and construction of the building need to be developed. While these strategies are often prescribed by codes, a prudent designer or builder will seek the best practices (not just the minimum standard required by the Code) to ensure that all of the fire control goals are met and that optimum fire safety is provided throughout the life of the building (not just at the time of construction). A programmed means to enable designers and builders to meet these goals is presented in the next section.

MEETING FIRE CONTROL GOALS

A simple method is available to determine the measures that can be used to meet fire control goals for multi-family residential buildings. This method is extracted from *NFPA 550—Guide to the Fire Safety Concepts Tree*,⁷ which is often used in developing fire control measures for large, complex buildings.

The first level in the decision about which fire control measures to adopt is depicted in Figure 2.1. The decision suggests that to achieve the fire control goals, one must either prevent ignition, or manage the impact of a fire, if ignition occurs. As explained earlier, it is impossible to prevent ignition in any building; therefore, the most effective way to achieve the fire control goals is to focus on managing the impact of the fire.

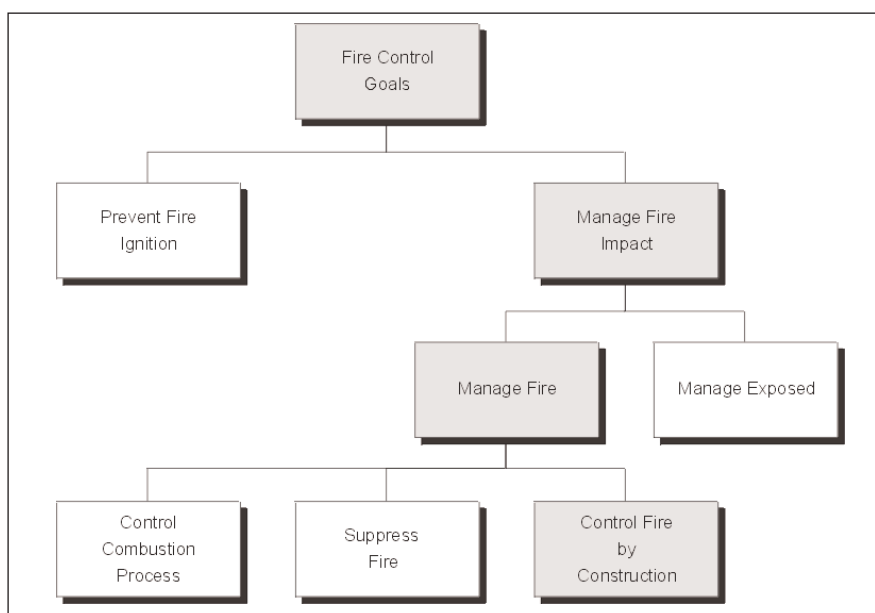

Figure 2.1: *Managing fire*

Figure 2.1 shows the two available options to manage the impact of fire; that is, to either manage the people, property or functions exposed to the fire, or to manage the fire itself.

Designers and builders can try to exercise some degree of control over the occupants or limit the building’s occupancy but, once the building is occupied, these are often difficult or impossible to manage. Prohibiting propane barbecues on balconies or limiting the maximum number of occupants in each apartment are examples of the operational controls that might be imposed on residents of MFBs.

For designers and builders, managing the people in a fire is accomplished, in part, by providing critical facilities such as fire alarm systems in the building to alert people of a fire. As well, exit facilities in the form of corridors and stairs must be provided to facilitate escape once the occupants are alerted to an emergency situation. In the end, the designer or builder has little ability to

⁷ “NFPA 550—Guide to Fire Safety Concepts Tree,” National Fire Protection Association, Quincy, MA, 1995.

manage the operational aspects of the building. In order to help meet the fire control goal, therefore, the designer or builder must incorporate design features into the building intended to manage the fire in multi-family buildings.

In managing the fire, there are three options for achieving the fire control goals, as shown in Figure 2.1, page 2-3. The management of fire is attained either by:

- Controlling the combustion process,
- Suppressing the fire, or
- Controlling the fire by construction.

Controlling the combustion process involves controlling the fuel within the building, including parts of the building itself. In MFBs, the contents of the building, that is the occupants' possessions and furniture, are typically the first objects ignited in a fire. The contents become a ready supply of fuel for the combustion (fire growth) process. Controlling the contents is beyond the current scope of building codes and thus beyond the control of designers and builders. The interior finish materials, as well as exposed structural components, can also become a supply of fuel for the combustion process. Controlling combustion by attempting to eliminate such sources of fuel, by using totally non-combustible furniture and construction materials, is often not a practical consideration for designers and builders of MFBs.

Fire management can also be achieved by suppressing the fire by installing an automatic sprinkler system in the building. Although the NBCC and most provincial building codes do not mandate automatic sprinkler systems for low-rise MFBs, this practice is growing in use in multi-family buildings. Today, there is considerable debate, relating primarily to reliability and cost effectiveness, about the installation of suppression systems. While active fire suppression through the use of automatic sprinkler systems can be a viable strategy for fire control in multi-family buildings, it is not the focus of this *Guide*. Builders and designers are encouraged to explore this option for their projects where it may be cost-effective, particularly where it complements other fire safety requirements.

As shown in Figure 2.2, page 2-5, fire control can also be achieved through passive fire resistant construction. This option is used in all multi-family buildings and is the main focus of this *Guide*. Fire control is achieved through the construction of fire separations that are barriers to the unimpeded movement of fire. These are designed with the intent of containing a fire to a specific compartment, usually an apartment or another space for a specific period of time. The construction must address both preventing the fire from spreading between units or fire compartments and preventing the collapse of the building as it is exposed to fire.

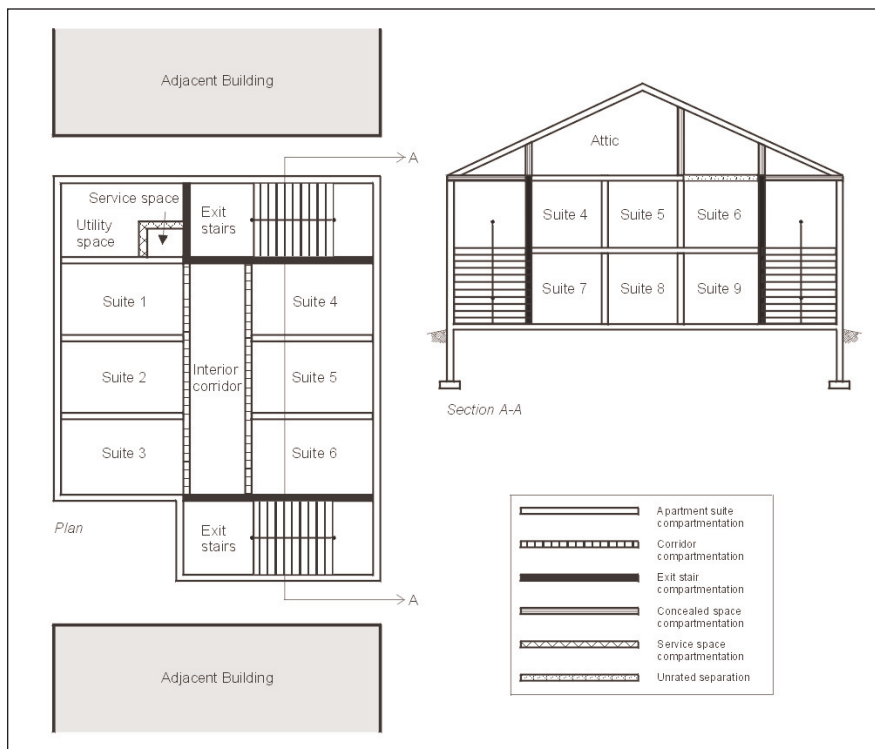

Figure 2.2: Apartment suite compartmentation

FIRE CONTROL BY CONSTRUCTION

In order to contain a fire to the compartment of origin, wall and floor assemblies must be carefully constructed and doors and windows (often referred to as *closures* by building codes) must be properly selected. Most fires in multi-family buildings do not spread by the failure of compartment walls or structural assemblies, attesting to the effectiveness of such assemblies in controlling fire.⁸ Fires most often spread through open doors or windows, or through concealed spaces that were not properly firestopped. While this *Guide* will not focus on the construction of doors and windows to prevent fire spread, it will address fire stopping (see also Chapter 6, page 6-1). Fire doors and windows can be selected from extensive lists of tested and certified products by accredited testing laboratories, such as Underwriters’ Laboratories of Canada⁹ and Intertek Testing Services.¹⁰

In multi-family buildings, there are several places where fire spread is controlled by construction, and consequently, where fire can possibly spread if the construction is inadequate. The following are some of the most common examples of construction approaches intended to contain the spread of fire (refer to Figure 2.2):

⁸ Coté, A.E., “Fire Protection Handbook,” 18th Edition, National Fire Protection Association, Quincy, MA, 1997.

⁹ “List of Equipment and Materials—Fire-resistance,” Underwriters’ Laboratories of Canada, Toronto, ON.

¹⁰ “Intertek Certification Listings,” Intertek Testing Services, Coquitlam, BC.

Apartment suite compartmentation: This method is possibly the most common use of fire barriers in multi-family buildings—the separation of one apartment from another. This compartmentation involves the use of both fire-rated wall and floor assemblies to help confine the fire to the apartment of origin.

Corridor compartmentation: When a fire occurs in a multi-family building having corridors used as common means of egress from dwelling units, occupants must be able to reach the exit stairs. The route to the exit stairs is typically an interior corridor on each floor separated from the adjacent dwelling units or service spaces by walls or partitions constructed as fire separations.

Exit stair compartmentation: The primary means by which occupants exit a MFB is through exit stairs, usually located within individual units or at both ends of the interior corridor at each floor level in typical apartment buildings. These exit stairs are required to be separated from the remainder of the building by walls constructed as fire separations.

Service space compartmentation: Separating service spaces such as boiler rooms, furnace rooms and electrical rooms is an important approach to containing fire and keeping it from spreading into other compartments. Multi-family buildings also contain both vertical (shafts) and horizontal service spaces that contain electrical and plumbing services and heating and air conditioning ductwork. Shafts are required to be separated from adjacent floor spaces by fire-rated walls. Shafts must also be separated from horizontal service spaces, unless the horizontal space is separated from the room below with fire separation with a rating equivalent to that of the vertical separation. The proper fire stopping and fire dampering of services as they enter and exit these spaces is one of the major fire spread issues that often is not adequately addressed by designers and builders.

Concealed space compartmentation: There are always concealed spaces in multi-family buildings through which fire can spread. These range from soffits to attic spaces to pipe chases. To control fire spread, these spaces are divided into smaller areas, often by extending fire separations located adjacent to them. For example, unless the ceiling membrane beneath the roof assembly provides enough fire-resistance, an apartment demising wall needs to extend through a common roof space to the underside of the roof deck to ensure that fire does not bypass the fire separation below.

Building-to-building compartmentation (firewalls): Occasionally firewalls are used to divide large buildings into smaller “buildings.” This often permits the use of wood-frame construction where steel or concrete would otherwise need to be used for the larger, single building. Firewalls are generally free-standing walls that are designed to prevent fire spread even in the case of the total destruction by fire of the building on one side of the wall. In essence, these are fire separations that are built to more stringent requirements than typical suite separations used in wood-frame construction. The Canadian Concrete and Masonry Codes Council has produced a useful publication on firewalls that provides additional details on the use and construction of such walls.¹¹

This *Guide* focuses primarily on the best practice for the design and construction of interior fire separations, which are the basic elements in controlling fire by construction. As indicated earlier, they constitute the most commonly used approach to managing fire spread in multi-family buildings.

¹¹ “Firewalls—A Design Guide,” Canadian Concrete and Masonry Codes Council, 1992.

FIRE STOPPING

Fire stopping is intended to prevent the movement of fire through concealed spaces within building assemblies. Fire stopping also prevents fire from spreading through openings in floors and walls created by services penetrating the assembly. In many ways, fire stopping can be viewed as increasing the reliability of a fire separation. The absence of appropriate fire stopping is one of the primary reasons that fire control by compartmentation fails. It therefore deserves special attention by designers and builders of multi-family buildings. Fire stopping can take a number of forms. These include:

Concealed space barriers: Typically, any concealed space that extends past the end of a fire separation is required to be blocked by a barrier. These barriers are required by Canadian building codes to remain in place and prevent the passage of flames for fifteen minutes when subjected to a standard fire test exposure (discussed in Chapter 3, page 3-1). For this purpose, most designers or builders will choose a generically accepted fire stopping material such as gypsum board, sheet steel, solid lumber, plywood or oriented strand board (OSB). Spaces commonly fire stopped in this manner include combustible cavity walls, dropped ceilings, soffits, attic spaces and crawl spaces. Canadian codes contain different fire stopping requirements, depending on the size of the space and the surface flammability of the materials in the space. See Figure 2.3, page 2-8.

Through-penetration fire stopping: Most multi-family buildings have locations where pipes, ducts or cables penetrate fire-rated floor or wall assemblies, and where floor and wall assemblies are joined. In the former case, the size of the opening often exceeds the size of the pipe, duct or cable and, as such, must be filled with an appropriate fire-stopping material. In addition to numerous proprietary materials that have been tested and certified for this purpose, generic materials, such as mineral wool insulation, can be used to fill these gaps to ensure that the continuity of the fire separation is maintained. While fire stopping around through-penetrations will not be addressed in this *Guide*, it is critically important to controlling the spread of fire. Additional information is available in the Underwriters' Laboratories of Canada publication, *ULC 40 U19 Fire Stop Systems*. The fire stopping of gaps where floor and wall assemblies join is addressed in wall and floor assembly details of Chapter 6, page 6-1.

THE PHYSICS OF SOUND

Controlling the passage of sound in buildings begins by reviewing the basic physics of sound movement. This review introduces key terminology and describe the properties of sound, how it moves from one space to another and how it interacts with building materials. This chapter also reviews the basics of sound control including the fundamentals of airborne sound, impact sound and flanking noise.

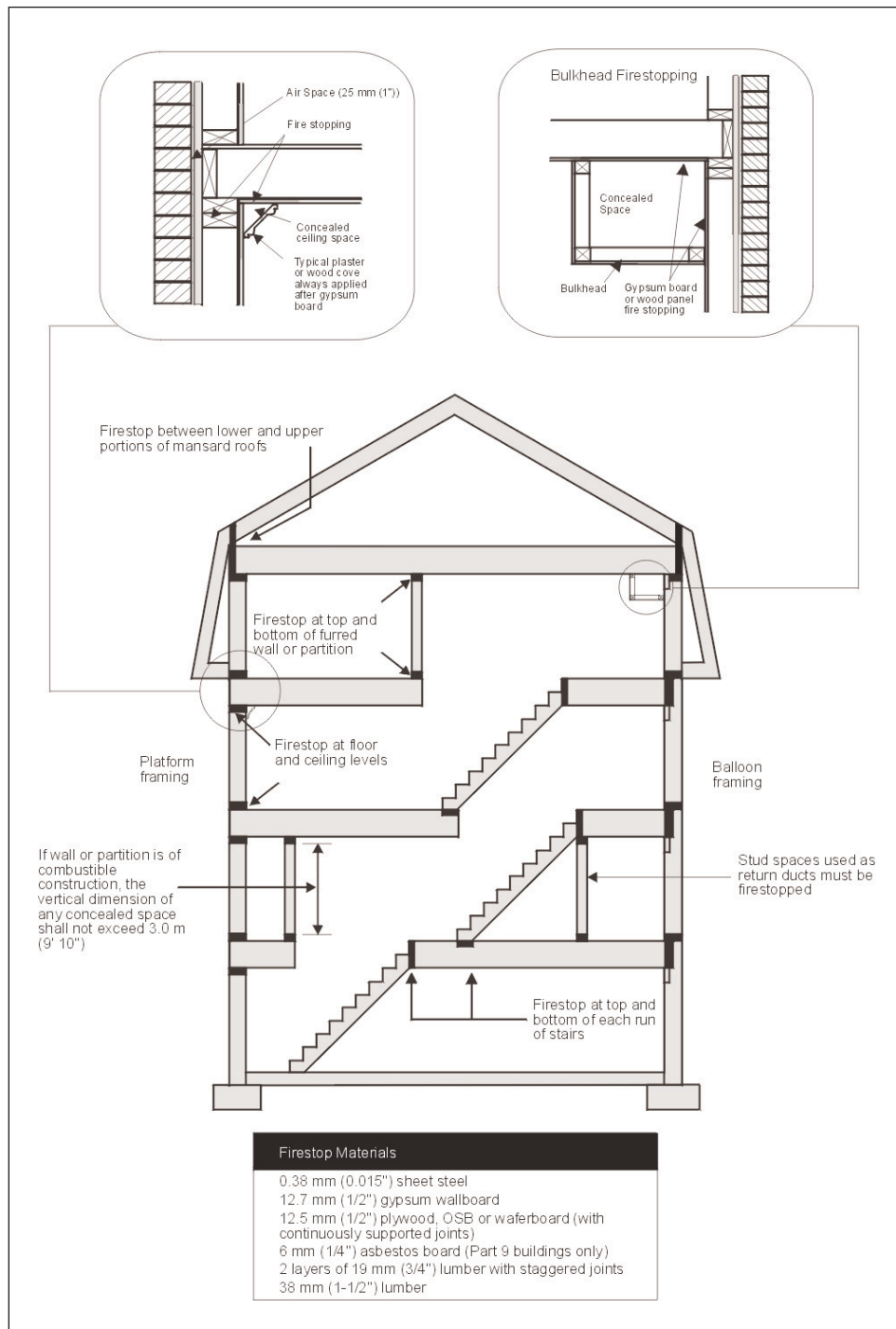

Figure 2.3: Fire stopping

While people recognize sound and noise, the physics of sound movement is quite complex. The steps that are involved in controlling the movement of sound from one space to another in buildings are not nearly as complicated. Understanding the fundamental concepts and the terms used to describe them is the first step in selecting assemblies that work.

Sound sources radiate energy through air, water or solid objects. As sound vibrations strike the eardrum and cause it to vibrate, the process we call *hearing* begins.

SOURCE OF SOUND

How are sounds generated? A guitar string that's made to vibrate by being plucked or a vibrating speaker cone are both examples of how sound can be produced. The movement of the speaker diaphragm compresses and expands air in its vicinity. These disturbances travel away from the sound source as sound waves. Like a stone that's dropped into a still pond, the sound moves through air in all directions until it hits an obstruction or until it dissipates and is no longer perceptible.

In buildings, sounds are generated by:

- People (walking, talking and so on).
- TV sets, audio systems and other entertainment equipment.
- Household appliances.
- HVAC equipment.
- Water and waste piping.

SOUND FREQUENCY

The number of oscillations per second of a source is known as the frequency and is measured in cycles per second, or Hertz (Hz). The more rapidly a source vibrates, the higher the pitch of the sound it makes. For example, a piccolo's highest note will register at approximately 5,000 Hz, whereas an upright bass can play as low as 40 Hz. Virtually all sources of sound produce several different frequencies simultaneously and if the sound is discordant, it's often referred to as noise. The human ear can hear sound frequencies as low as 20 Hz and as high as 20,000 Hz.

Frequency is an important concept for good building design for two reasons. First, the human ear perceives loudness differently at different frequencies. Second, low frequency sounds are much more difficult to control in buildings.

SOUND LEVELS

The energy associated with a sound wave is measured in decibels (dB). The term is also used to measure sound pressure level. The larger the vibration of the source and the disturbance of the air, the louder a sound is perceived by the ear and the greater the sound pressure level. Table 2.1, page 2-10, identifies typical sound pressure levels associated with common sound sources.

Table 2.1: Sound pressure levels for common sound

Noise source	Decibels (dB)
Jet takeoff, artillery fire	120 or more
Rock band or home theatre system	100–120
Unmuffled truck or motorcycle	80–100
Average radio or TV	70–90
Human voice at 1 m (3.2 ft.)	55–60
Background in private office	35–40
Quiet home	25–35
Buzzing insect at 1 m (3.2 ft.)	15–25
Threshold of hearing	0

The human ear is not equally responsive to all sound frequencies; that is, sound at the same level but with different frequencies is not perceived to be equally loud. To adjust for the perception of the human ear, the dBA unit was developed. It corresponds to the human assessment of overall loudness.

BEHAVIOUR OF SOUND IN BUILDINGS

When an airborne sound hits the surface of a building assembly, the energy contained in the sound wave in part transmits through the assembly, reflects off the surface and is absorbed by the materials used as part of the assembly. Impacts can also generate sound that can transmit through a building assembly. Understanding how sound behaves within an assembly is the basis for devising strategies for controlling its movement.

SOUND TRANSMISSION AND SOUND TRANSMISSION LOSS

When sound waves strike one side of a partition, pressure variations cause the face of the partition to vibrate as some of the power in the sound wave is transferred into the partition. Some of this vibration energy reappears at the partition's second surface where it is re-radiated as sound. The partition transmits some of the sound from one side to the other. The partition also prevents some of the sound from re-radiating to the other side, referred to as the "sound transmission loss" of the partition.

Sound not only moves through materials, it also passes around them through cracks and voids by air leakage. Airborne sound leakage needs very little air to transport it and can often be reduced through good detailing and good planning.

Good sound barriers must be impervious to air. Examples of sound barriers include concrete, glass, gypsum board, plywood or other sheathing materials.

ABSORPTION

One method of reducing sound transmission in a cavity wall or floor is to place absorptive material, such as fibrous insulation, within the cavity of the assembly. The absorptive material will only be effective in absorbing sound waves in the cavity. A significant amount of sound energy can flank or bypass the cavity when front and back layers are solidly connected to each other.

Absorptive materials are normally quite porous. They interact with sound passing through them, converting the vibrations into heat. Absorptive materials are not sound barriers. They reduce sound energy in an enclosed space because sound repeatedly reflects from the surfaces of the spaces and passes through the sound-absorbing material many times. Each pass-through results in a small decrease in energy, with the cumulative effect being significant. A single pass provides very little sound attenuation unless the material is very thick. Thus, adding a carpet or acoustic tiles directly on a surface will not significantly improve the airborne sound insulation of the separation.

IMPACT SOUND

Impact sound is caused by a floor or wall being set into vibration by direct mechanical contact or impact. The sound is then radiated by the wall or floor surface into the cavity of the assembly. Floor vibrations can also be transmitted throughout the structure to walls and re-radiated as sound into adjoining spaces. For occupants, impact sound transmission can be a major issue and the source of considerable disturbance.

FLANKING SOUND

Sound that is transmitted into an assembly can short-circuit the cavity by moving across its top, bottom or sides. This type of sound transmission is often referred to as “flanking noise.” A flanking path is a path for sound transmission that involves elements other than the common partition between two spaces although the latter may still be involved. Figure 2.4, page 2-12, shows examples of flanking paths. Once sound has entered a structure and is propagating as vibration, it can travel for considerable distances. The vibrating structure continually re-radiates energy as sound from both sides.

The energy lost in travelling from one point to another depends on the materials and on the details of the construction. Proper detailing helps to reduce this type of sound transmission; however, its avoidance is nearly impossible. Flanking paths have much more serious consequences for impact sound transmission than for airborne sound transmission. This is because with impacts more vibrational energy gets transferred to the structure; vibrational energy often of low frequencies which is more difficult to control.

Published sound transmission ratings for individual floor and wall assemblies typically do not account for this type of flanking noise problem. In practice, flanking transmission will reduce the specific airborne and impact transmission ratings of an assembly. See Chapter 4, page 4-1, and Chapter 5, page 5-1, for additional details regarding flanking noise in floors and walls.

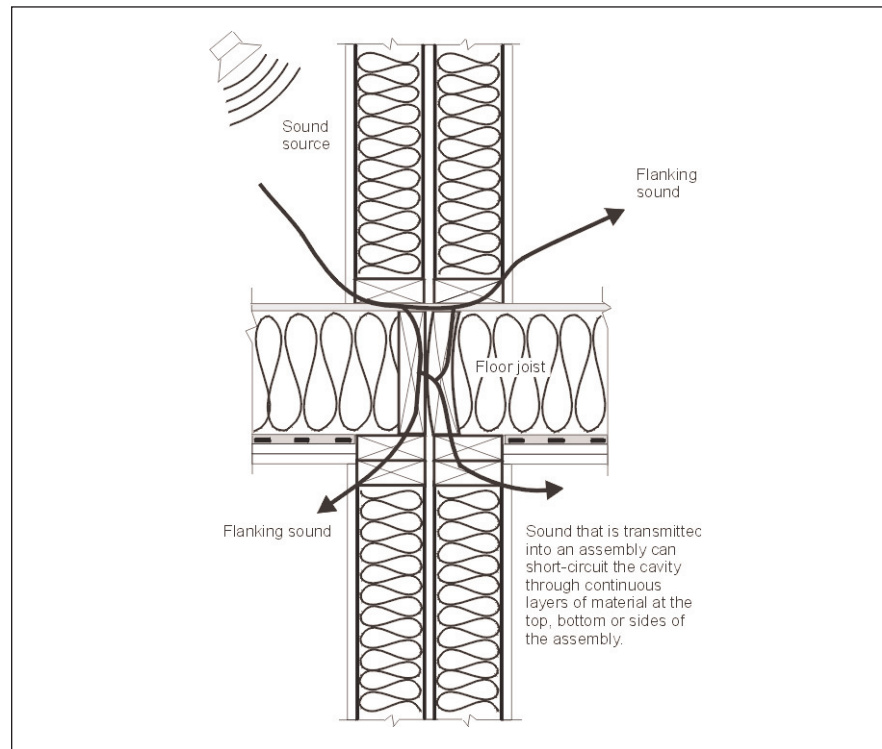

Figure 2.4: Flanking sound transmission

STEPS TO CONTROLLING SOUND TRANSMISSION

The transmission of sound through walls and floors can be improved by taking some easy steps:

- Create an airtight barrier to the passage of sound.
- Use heavier building materials in the construction of the wall or floor.
- Break the sound vibration path.
- Provide materials in the wall or floor cavity that can absorb sound.

Among these steps is the often-neglected approach of planning the building layout with sensible vertical and horizontal relationships between noise-generating spaces and spaces sensitive to transmitted sound.

BARRIERS TO THE PASSAGE OF SOUND

To prevent the passage of sound a continuous barrier is needed. A sound barrier must be impervious to air. Barriers to sound can include gypsum board, glass, plywood and concrete. Typically, a good sound barrier, in addition to being impervious to air, is also non-porous, solid and reasonably heavy.

Sound can leak through small holes and fissures in the sound barrier. Special attention to details is critical in providing an effective barrier. Normally, this calls for sealing of the perimeter of walls, careful detailing of wall

intersections, proper sizing and placement of windows, properly locating and installing doors, electrical outlets, heating ducts and mechanical equipment. Aside from attenuating sound, good details also reduce odours and pests migrating between suites and improve comfort and durability.

HEAVY BUILDING MATERIALS

Heavier, denser, building materials tend to block sound better than lightweight building materials. In the simplest terms, this might mean using double weight gypsum wallboard, for instance. The higher the transmission loss, the less sound that passes through the wall. See Figure 2.5.

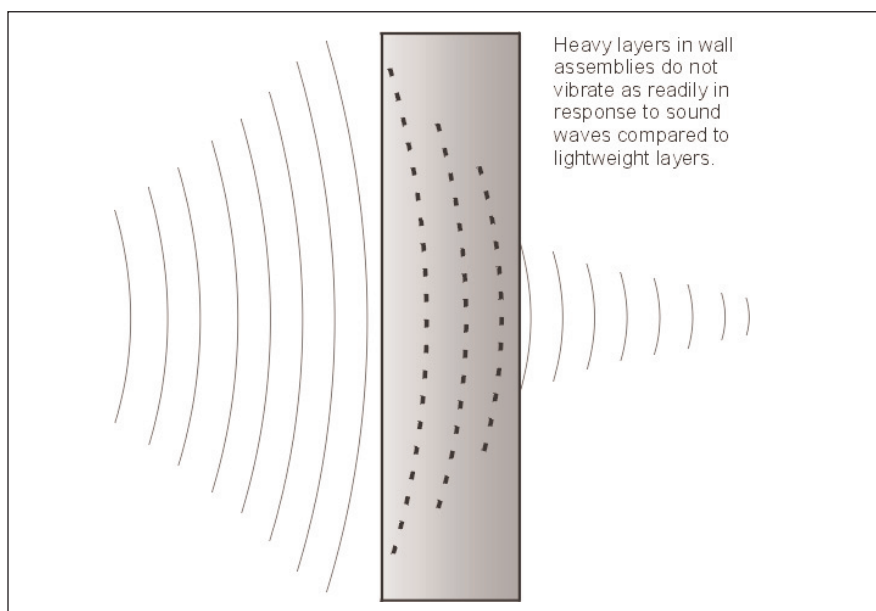

Figure 2.5: Heavy materials transmit less sound

BREAKING THE SOUND VIBRATION PATH

Cavity walls or floors provide an effective way of achieving good sound insulation without excessive weight. Acoustically, this type of construction performs best if the two layers are not solidly connected and there is sound-absorbing material in the cavity. In frame construction, staggering the studs in the wall or fastening horizontal resilient channels to the structural members are common approaches used to break the path of the travelling sound. The sound insulation is greatly reduced when vibrations are allowed to move from one wall face to the other through solid internal wall elements, such as studs or plates. Where sound transmission paths are broken once by a gap or by resilient channels, any additional breaks will have virtually no benefit. Resilient channels installed on both sides of a wall may be beneficial where flanking sound can enter the wall framing from above or below.

The thickness of the cavity that is formed will have an effect on the sound transmission losses. Every time the cavity thickness is doubled the sound attenuation or sound transmission losses increase substantially. See Chapter 4, page 4-1, for specific details about walls and Chapter 5, page 5-1, for specific details about floors.

USING SOUND-ABSORBING MATERIALS

Sound-absorbing materials are usually porous foams or fibrous layers through which sound passes easily. However, closed-cell foam plastics are generally not good sound absorbers. Sound-absorbing materials absorb sound by converting the vibrations of the air molecules into heat. They reduce sound levels in a room because the sound repeatedly passes through them losing energy each time. See Figure 2.6. Mineral wool, glass fibre, cellulose fibre, open cell foams and acoustical tiles are good examples of sound-absorbing materials.

Typically filling a wall or floor cavity with sound-absorbing materials like batt insulation can substantially reduce sound transmission, if the layers are properly isolated. The position of the sound-absorbing material in the cavity is not important as long as it is fairly well distributed within the cavity.

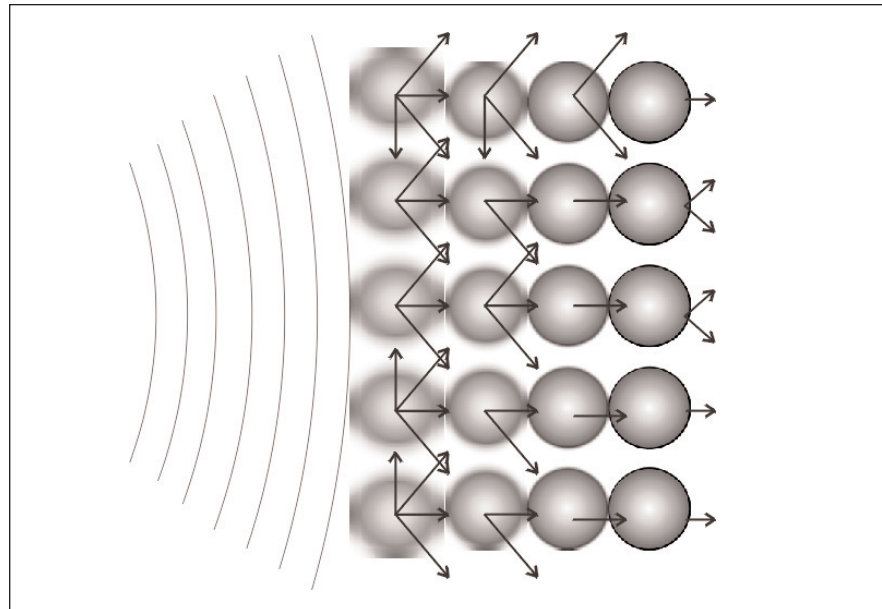

Figure 2.6: Sound-absorbing materials dissipate sound energy

IDEAL ASSEMBLIES

The ideal assembly to attenuate sound, as shown in Figure 2.7, page 2-15, and Figure 2.8, page 2-15, would include:

- Airtight construction, especially at penetrations.
- Two layers that are not connected at any point by solid materials.
- The heaviest layers that are practical.
- The deepest cavity that is practical, filled with sound-absorbing material.

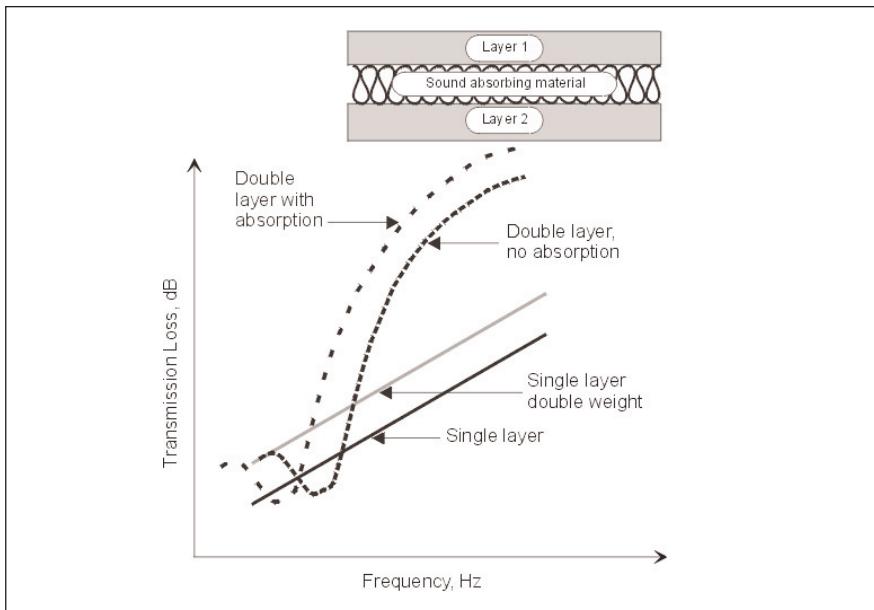

Figure 2.7: The ideal assembly

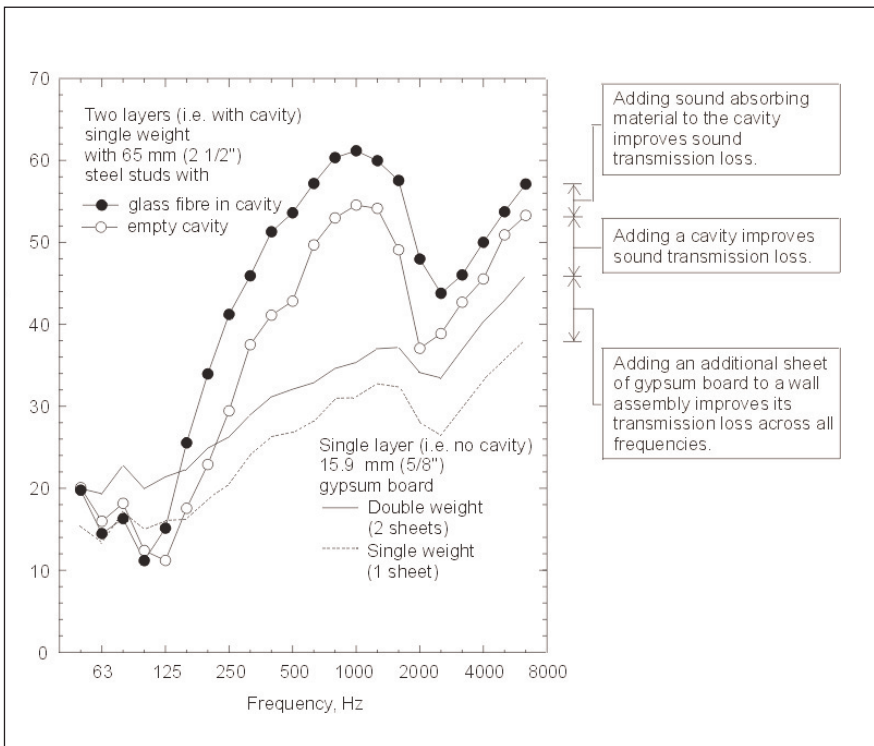

Figure 2.8: Effects of wall cavity and sound-absorbing materials on transmission loss

INTRODUCTION

The selection of an appropriate assembly to properly control fire spread and sound transmission is possible by using a system that rates each assembly's fire-resistance and sound attenuation properties. The *Fire-resistance Rating* (FRR) and *Sound Transmission Class* (STC) can be determined for wall and floor assemblies to assess these properties. Additionally, *Impact Insulation Class* (IIC) can also be assessed for floor assemblies. These are determined from tests of the performance of assemblies built under controlled conditions in a laboratory. It is important to understand that field performance can vary as any number of variables are introduced on-site that are not present in the lab.

This chapter defines FRR, STC and IIC and briefly outlines how each is determined for specific assemblies. The chapter presents, in summary form, the requirements of the National Building Code of Canada and other standards as they relate to the FRR and STC of assemblies in wood-frame, multi-family buildings. Although IIC is not mandated by the National Building Code of Canada, best practices to reduce impact sound transmission are presented. Finally, as already noted, this chapter discusses the variables that can compromise performance in the field.

CONTROLLING FIRE SPREAD WITH WALL AND FLOOR ASSEMBLIES

Most fires in suites or other compartments in residential buildings typically do not grow to a sufficient size to affect the structural integrity of wall or floor assemblies. Canadian statistics show that, in all apartment buildings, approximately 82 per cent of fires will not grow to the flashover stage, involving everything in the room burning, but will remain as smouldering or small flaming fires, such as in wastepaper baskets.¹² The remaining 18 per cent of fires do grow to flashover and unless there is manual or automatic fire suppression, they can create significant heat exposures for wall and floor assemblies. As shown in Figure 3.1, page 3-2, for a typical bedroom fire exposure, fire grows rapidly to its maximum temperature and then decreases in intensity as the fuel is consumed. Such a fire can impose a major stress on wall and floor assemblies.

Fire in multi-family buildings can be controlled by tailoring the construction to be used for wall and floor assemblies to match the fire exposure risk. This implies quantifying the risk of multi-family building fires, including fires in any compartment. This is not easy, due to the great variation in the types and quantity of fuel, the arrangement of fuels in the compartment, the size of the compartment and the compartment's ventilation. To balance that risk in a standardized manner, most designers and builders make use of the assembly's ability to resist fire spread, commonly called fire-resistance, rather than assessing risk in every situation.

The fire-resistance of wall and floor assemblies along with other structural and non-structural members or assemblies can be easily rated based on the exposure

¹² Gaskin, J. and Yung, D., "Canadian and U.S.A. Fire Statistics for Use in the Risk-Cost Assessment Model," IRC Internal Report No. 637, National Research Council of Canada, 1993.

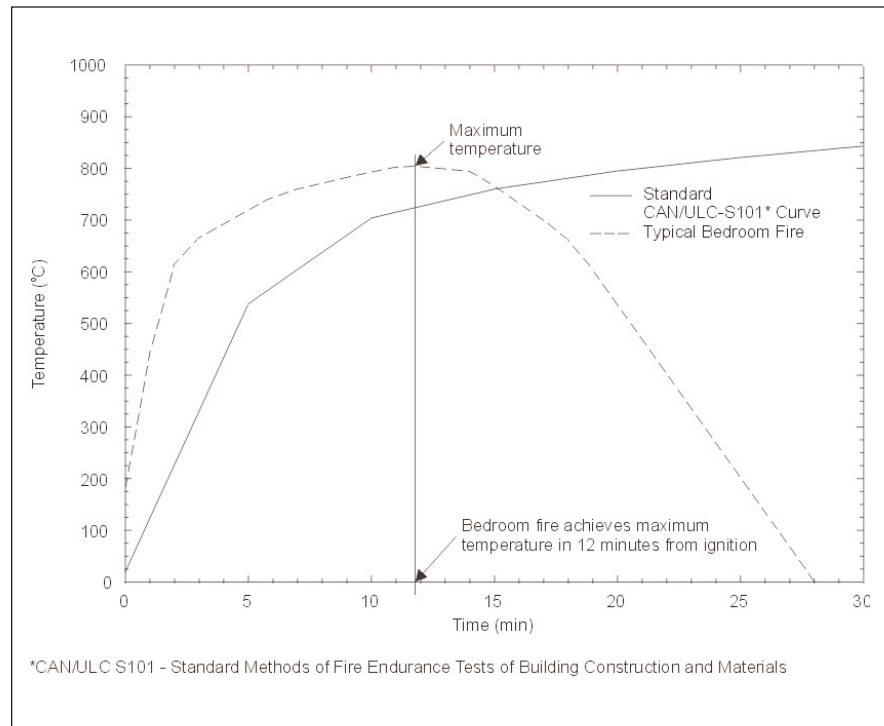

Figure 3.1: Typical fire exposures

of the assembly or member to a standard fire. The standard fire may be more or less severe than the expected fire exposure in a real fire, however, it has been generally accepted that the standard fire test exposure is a reasonable method to be used to evaluate the fire-resistance of assemblies and structural members. Figure 3.1 illustrates the standard fire exposure used in Canada as compared to a typical bedroom fire.¹³

FIRE-RESISTANCE RATINGS

The ability of a floor or wall assembly or a structural member to withstand exposure to a standard fire can be measured and is defined as its fire-resistance rating. The NBCC defines fire-resistance rating as follows:

Fire Resistance Rating is the time in hours or fraction thereof that a material or assembly of materials will withstand the passage of flame and the transmission of heat when exposed to fire under specified conditions of test and performance criteria, or as determined by extension or interpretation of information derived therefrom as prescribed in this Code.

Fire-resistance ratings, as measured in the standard fire test, provide a relative indication of how well an assembly or structural member will perform in resisting a real fire. In Canada, there are a number of ways to demonstrate fire-resistance that have typically been accepted by various authorities having jurisdiction.

- **Tested assemblies:** These are assemblies that are tested by a recognized testing laboratory and a report of the findings prepared.

¹³ Coté, A.E., “Fire Protection Handbook,” 18th Edition, National Fire Protection Association, Quincy, MA, 1997.

- **Certified or listed assemblies:** These are assemblies that are tested by a recognized testing laboratory and listed in a publication by a recognized certification organization as providing a specified fire-resistance rating.
- **Assigned ratings:** “Appendix A” of the NBCC contains an extensive list of assemblies with assigned fire-resistance ratings based on a review of fire test data. If a designer or builder selects an assembly from the Tables in Appendix A, the assembly is deemed to satisfy the intent of the fire-resistance rating requirements in the NBCC.
- **Ratings by calculation:** As referenced above in the definition of fire-resistance rating, the NBCC permits the fire-resistance rating of an assembly to be determined by an extension or interpolation of fire test and other data. “Appendix D—Fire Performance,” of the NBCC contains information that allows designers to easily calculate the fire-resistance rating for walls, floors, beams and columns. The calculation method for walls and floors, commonly referred to as the “component additive method” was developed in the 1960s after an extensive review of the fire test information. Calculation methods for glued laminated wood beams and columns as well as concrete-filled steel columns were developed later. Typically, calculations using the information contained in “Appendix D” or other reliable fire protection engineering sources are undertaken by qualified fire protection engineers, architects and other competent individuals.^{14, 15}

Wall and floor assemblies are tested by exposing them to a fire in a furnace also designed to apply structural loading, when applicable, as part of the fire test. Walls are exposed to fire on one side only, while floors are exposed to fire from below. Figure 3.2 shows an example of a furnace designed to test wall assemblies.

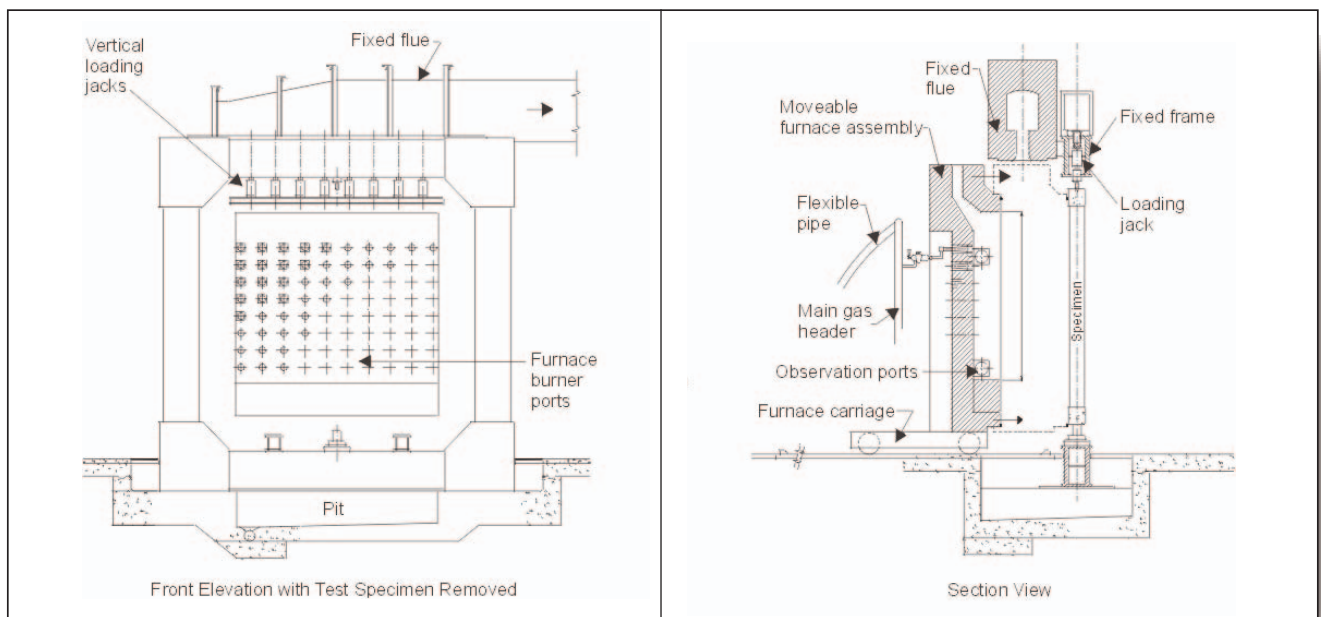

Figure 3.2: Example of fire-test furnace for wall assemblies

¹⁴ “Society of Fire Protection Engineers Handbook on Fire Protection Engineering,” Society of Fire Protection Engineers.

¹⁵ “American Wood Council Technical Report 10—Calculating the Fire Resistance of Exposed Wood Members Test for Determining Fire Resistance Ratings,” American Wood Council.

For floors, the test assembly is installed over a horizontal furnace chamber and the structural loading system is placed on top of the test assembly.

The test method used in Canada to measure fire-resistance, using either a wall or floor furnace, is described in *CAN/ULC S101—Standard Methods of Fire Endurance Tests of Building Construction and Materials*.¹⁶ This standard test method is referenced in the NBCC and is similar to *ASTM E119—Test Methods for Fire Tests of Building Construction and Materials*,¹⁷ which is the primary test standard for fire-resistance used in the United States.

For wall and floor assemblies, the test assembly is constructed to specific dimensions. Assemblies that are intended to support live loads are tested with superimposed loads, calculated based on the load-carrying capacity of the final assembly (that is, as close as possible to the maximum load permitted by structural design criteria).

Furnace burners are ignited and controlled so the temperatures in the furnace follow as closely as possible the time-temperature curve of the standard fire exposure shown in Figure 3.1, page 3-2. The average temperature inside the furnace is carefully monitored to ensure the prescribed temperature profile is followed. The test continues until one of the failure criteria specified in the test standard occurs; that is:

- If the test specimen is a load-bearing assembly, failure to sustain the applied load during the test or where its deflection allows heat and flame to breach the assembly and ignite cotton material on the non-exposed side. (This is determined by touching a piece of cotton material to various points on the non-exposed side of the assembly.)
- Passage of flame from the furnace side through the test assembly to the non-fire-exposed side.
- If the test specimen is not a load-bearing assembly, passage of gases hot enough to ignite cotton waste.
- Transmission of heat so as to raise the average temperature on the unexposed surface more than 140°C (284°F) above its initial temperature.
- Transmission of heat so as to raise the temperature of one of the nine thermocouples on the unexposed face to greater than 180°C (356°F).
- Passage of the hose-stream test, if required.

With the exception of the hose-stream test, these failure criteria are self-explanatory. The hose-stream test is applied to wall assemblies as a means to evaluate the capability of the assembly to withstand the impact, erosion and cooling effects of a solid hose stream directed at the assembly from the fire-exposed side. This is applied to assemblies that achieve fire-resistance ratings of one hour or more.

Based on these test criteria, an assembly is assigned a fire-resistance rating of 3/4 h., 1 h., 1-1/2 h., 2 h., 3 h. or greater. While the actual result from the test may be greater than one of these nominal ratings, the next lowest rating is what is reported. For example, if an assembly achieves a test result of 56 minutes, it is assigned a nominal fire-resistance rating of 3/4 h. In MFBs, the minimum fire-resistance rating required by the NBCC for floor and wall assemblies designed as fire separations between dwellings is 3/4 h.

¹⁶ “CAN/ULC S101—Standard Methods of Fire Endurance Tests of Building Construction and Materials,” Underwriters’ Laboratories of Canada, Toronto, ON.

¹⁷ “ASTM E119—Test Methods for Fire Tests of Building Construction and Materials,” American Society for Testing and Materials, Philadelphia, PA.

FIRE SEPARATIONS

While the fire-resistance rating of a floor or wall assembly is an indication of how long the assembly can withstand a standard fire exposure, the assembly itself must possess other characteristics to be considered a fire separation. The definition in the NBCC for a fire separation reads: “A fire separation is a construction assembly that acts as a barrier against the spread of fire.”

A floor or wall assembly classified as a fire separation may or may not have a fire-resistance rating determined by testing. For example, while a wood-stud wall, finished with gypsum wallboard on both sides, may be a fire separation with a 3/4 h. fire-resistance rating, a glazed wall with a fire-resistance rating of only a few minutes (an unrated assembly) can also be designed as a fire separation.

The most important characteristic of a fire separation is that it must be a continuous barrier against the spread of fire. This means that:

- Any large opening, such as a doorway or window, must be equipped with a closure.
- The terminations of the fire separation and any service penetrations through it must be firestopped to prevent the passage of smoke and flames.

A closure is a device or assembly that closes an opening through a fire separation or an exterior wall. A door, a shutter, wired glass or glass block, together with all components such as hardware, closing devices, frames and anchors would all be considered closures. Only when a fire separation is required to have a fire-resistance rating (i.e., 3/4 h. or greater) must the closures also be fire-rated. Effectively, closures act to provide the required continuity for the non-solid portions of fire separations. To achieve the required continuity, closures are assigned fire-protection ratings defined as the time in hours that the closure will withstand the passage of a flame when exposed to fire under specified test conditions and performance criteria.

Two significant factors distinguish a fire protection rating for a closure from a fire-resistance rating for a wall or floor assembly:

1. For a closure, a fire protection rating is required only to prevent the passage of flame. There are typically no average temperature rise or maximum temperature failure criteria (although such limits are required by the NBCC for some doors).
2. A closure usually has a lower fire-protection rating than the fire-resistance rating of the assembly in which it is installed. For example, a fire separation required to have a 1 h. fire-resistance rating is permitted to have closures with a 3/4 h. fire protection rating.

Fire stopping delays the movement of fire in concealed spaces within an assembly and around penetrations through an assembly. In wall assemblies, fire stopping must be installed at the top and bottom of the assembly to prevent smoke from escaping at the top and to prevent oxygen from feeding the fire from below. In all cases, fire stopping must be installed to meet specific requirements (see the NBCC).

There are many aspects of fire separations and closures for multi-family buildings of which designers and builders should be aware. Some of these will be addressed in Chapter 4, page 4-1, and Chapter 5, page 5-1. In all cases, designers and builders should have a good working knowledge of these provisions of the National Building Code of Canada to ensure that the objectives of fire control by construction are more likely to be met.

NBCC AND FIRE SEPARATIONS

In Chapter 2, page 2-1, the concepts of fire control by construction for multi-family buildings were introduced and examples provided of locations where fire compartmentation is suggested by the NBCC to achieve fire control goals. This section will provide additional information on multi-family building compartmentation, including NBCC minimum limits for fire-resistance ratings for fire separations.

BUILDING CONSTRUCTION

Table 3.1, page 3-7, contains some of the more common NBCC limits for fire-resistance ratings of the major construction assemblies of wood-frame multi-family buildings. The intent of this level of fire-resistance is to increase the likelihood that the overall building itself will withstand prolonged fire exposure and that floors and walls will continue to remain in place to enable egress by occupants and entry by the fire service for firefighting.

The most common fire compartments found in multi-family buildings are:

Apartment suite compartmentation: Typically, apartments or suites in multi-family buildings are required by the NBCC to be separated from each other by wall and floor assemblies designed as fire separations having a minimum 1 h. fire-resistance rating. This rating is reduced to 3/4 h. for smaller wood-frame buildings up to 3 storeys in height.

Corridor compartmentation: In multi-family buildings, walls or partitions enclosing public corridors that provide access to an exit from more than one apartment or suite are required by the NBCC to be 1 h. fire separations. This required rating is reduced to 3/4 h. where 3/4 h. or lesser ratings are permitted for floors in Table 3.1, page 3-7.

Exit compartmentation: The NBCC requires that walls or partitions enclosing exits be constructed as fire separations having a fire-resistance rating not less than those required for floors in Table 3.1, page 3-7.

Service space compartmentation: The NBCC requirements for service space fire separations vary depending on the hazard presented. For example, a fuel-fired appliance may be required to be enclosed in 2 h. fire separations, whereas certain rooms with non-hazardous equipment may not require fire separations at all.

Concealed space compartmentation: Vertical service spaces (shafts) are required by the NBCC to be enclosed by walls or partitions constructed as fire separations with fire-resistance ratings typically less than those required for the floor assemblies which they penetrate. Similar requirements apply to horizontal service spaces that penetrate a required vertical fire separation.

Table 3.1: Required fire-resistance in wood-frame multi-family buildings

Building size	Sprinklered	Construction	Assembly	Fire-resistance	Fire separation
Up to 4 storeys, area limits	Yes	Wood-frame or heavy timber*†	Floors	1 h.	Yes
			Mezzanines	1 h.	No
			Internal floors	1 h.‡	No
Up to 3 storeys, greater area limits	No	Wood-frame or heavy timber*†	Floors	1 h.	Yes
			Mezzanines	1 h.	No
			Roofs	1 h.	No
Up to 3 storeys, area limits	Yes	Wood-frame or heavy timber*†	Floors	3/4 h.	Yes
			Mezzanines	3/4 h.	No
			Internal floors	3/4 h.‡	No
Up to 3 storeys, area limits	No	Wood-frame or heavy timber*†	Floors	3/4 h.	Yes
			Mezzanines	3/4 h.	No
			Internal floors	3/4 h.‡	No

* Non-combustible construction is also permitted.
 † Heavy timber members need to be designed to provide 1 h. fire-resistance rating.
 ‡ No rating is required for unstacked dwelling units.

Building-to-building compartmentation (firewalls): In some cases, buildings can be subdivided into smaller buildings through the use of firewalls. This often permits the use of less-restrictive requirements, including those in Part 9 of the NBCC.

As can be seen in this chapter, the designers and builders of wood-frame, multi-family buildings have numerous occasions to deal with fire separations and fire-resistance ratings when strategies for fire control by building construction are employed. Chapter 4, page 4-1, and Chapter 5, page 5-1, provide designers and builders with a number of design options that they can use to achieve fire control in low-rise wood-frame multi-family construction.

SOUND TESTING OF WALLS AND FLOORS

In a laboratory, wall assemblies to be tested are built and placed between two reverberation rooms constructed so that transmission of vibration from one to the other is minimized. Noise is generated in one room and the sound pressure levels are measured in both, as shown in Figure 3.3. In the laboratory, unlike in real buildings, the only sound transmission path between rooms is through the wall or floor assembly being tested.

Sound pressure levels are measured and corrected to account for the acoustical properties of the receiving room. The ability to reduce sound energy is measured in decibels (dB) at various frequencies. This characteristic of the assembly is also referred to as the “sound transmission loss.” The higher the transmission loss, the less sound that passes through the wall. Figure 3.4, shows typical sound transmission losses through a variety of construction materials.

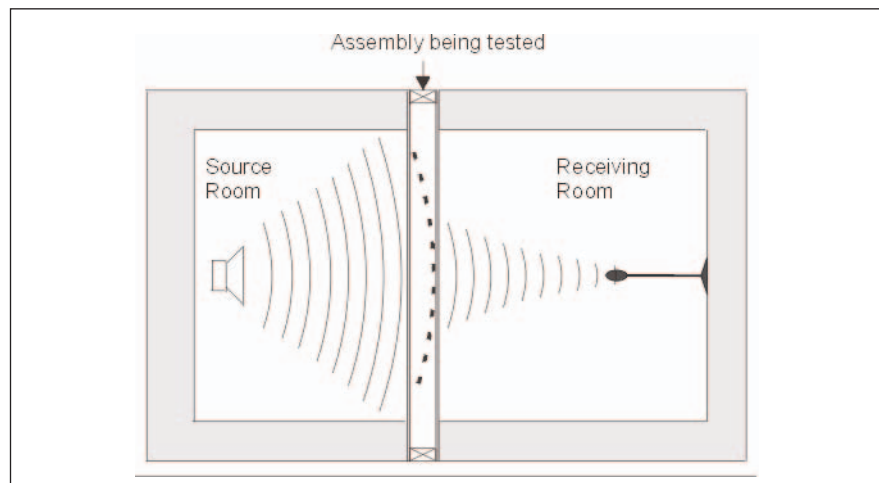

Figure 3.3: Measuring sound transmission loss in the laboratory

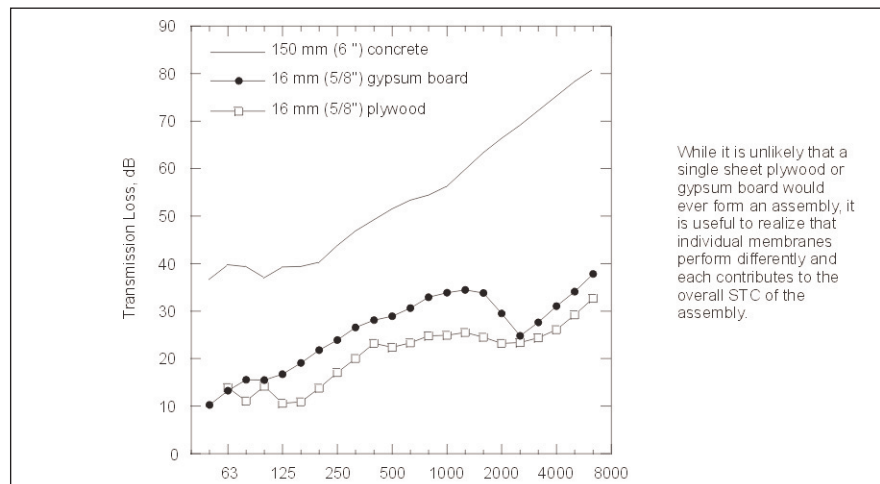

Figure 3.4: Transmission loss for common construction materials

Floor specimens are tested in the same way, except they are sometimes also subjected to tests intended to measure the impact insulation characteristics of the assembly. Unlike walls, the sound of footsteps and falling objects are often of concern with these assemblies. The National Building Code of Canada, it should be clear, does not include minimum requirements for the impact insulation characteristics of floors. The need for such requirements is currently being examined for future versions of the code.

WHAT IS SOUND TRANSMISSION CLASS (STC)?

Sound transmission class, or STC, is a numerical rating assigned to a wall or floor assembly, used to describe how well and how much it transmits sound. STC classifies the average noise reduction in decibels for sounds, like speech that pass through an assembly. A high STC rating for an assembly implies good sound attenuation characteristics. Table 3.2 shows generally how the STC ratings for walls relate to their ability to attenuate different sound.

Table 3.2: The audibility of speech and music through walls of various STC ratings

STC 45	Loud or amplified speech audible. Loud music audible, and bass notes particularly strong.
STC 50	Loud or amplified speech faintly audible. Loud music mostly just audible, but bass notes still quite noticeable.
STC 55	Loud music not generally audible, but bass notes still heard.
STC 60	Loud music inaudible except for occasional very strong bass notes.

Measured sound-transmission losses for specific assemblies are fit against a predetermined sound-transmission class contour that extends from 125 to 4,000 Hz. The STC of the assembly is read from the contour value at 500 Hz and provides an average measure of the transmission loss across 16 specific sound frequencies. Figure 3.5, page 3-10, illustrates how the STC contour is fitted to measured sound-transmission loss data from various wall and floor assemblies. STC can also be measured in buildings in the field. Measurements made in the field and not in a laboratory are identified using the FSTC or Field Sound Transmission Class designation.

The STC rating ignores low-frequency sound transmission below 125 Hz, which is often associated with mechanical systems, transportation sources and amplified music. It should be noted that low-frequency sounds can be a major cause for complaint in multi-family construction. A heavier assembly with the same STC as a lighter assembly may often outperform the lighter assembly at low frequencies. Chapter 4, page 4-1, and Chapter 5, page 5-1, identify specific measures that can be taken to deal with this type of sound.

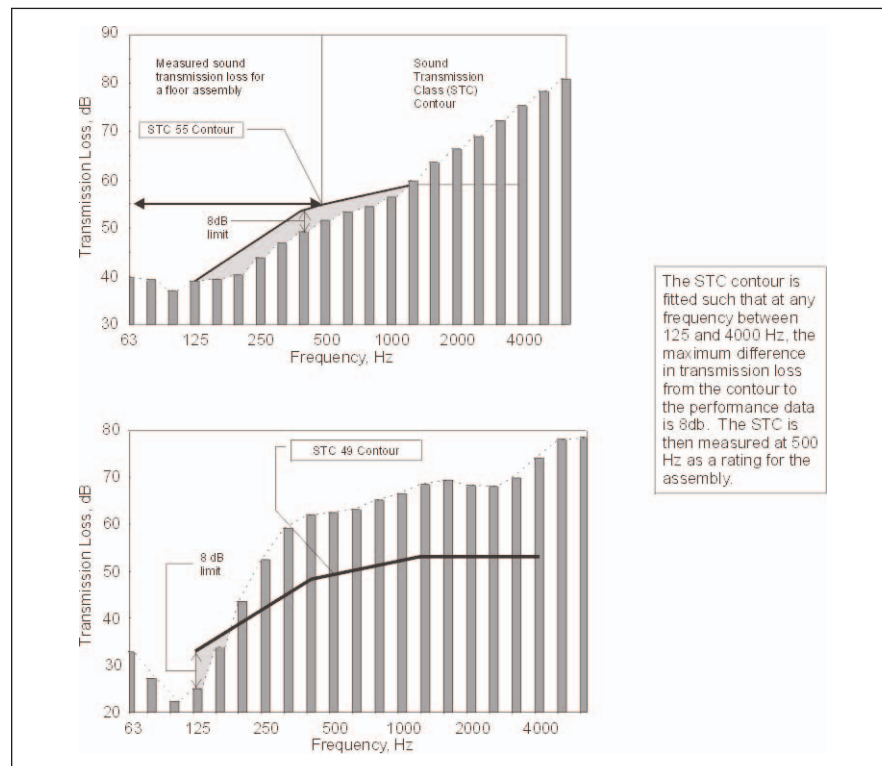

Figure 3.5: Fitting the STC contour to transmission loss data

STC ratings are sometimes difficult to understand since decibels cannot be added and subtracted. A 10 dB increase actually means increasing the sound energy 10 times, which is perceived as being about twice as loud by the human ear. Therefore, an STC 45 wall will allow about 10 times as much sound to pass compared to a wall with STC 55, and the sounds that come through will be perceived as about twice as loud. Similarly, a wall with an STC of 35 will seem four times noisier than the wall with STC 55.

WHAT IS IMPACT INSULATION CLASS (IIC)?

Just as there is a standard test for airborne sound, there is a similar test for impact sound that results in a rating called “impact insulation class” (IIC). The standard test method uses a tapping machine, shown in Figure 3.6 on page 3-11, that consists of a motor and turning shaft that lifts and drops five steel hammers on the floor a total of 10 times per second. Sound pressure levels are measured in the room below at specific frequencies, as illustrated in Figure 3.7, page 3-11.

An IIC contour is fitted to measured sound levels through the assembly in the same way the STC contour is fitted; however, only the frequencies from 100 to 3,150 Hz are used in determining the IIC rating. Figure 3.8, page 3-12, shows how the IIC contour is fitted. From the figure, the bars represent the sound pressure levels measured in the sound receiving room. The dotted line is the IIC contour. When a bar is higher than the dotted line, the difference between the bar and the dotted line is a deficiency. IIC is read on the right so it increases as the impact sound insulation improves. In this figure, the impact sound intensity pressure level is identified in addition to the impact insulation class.

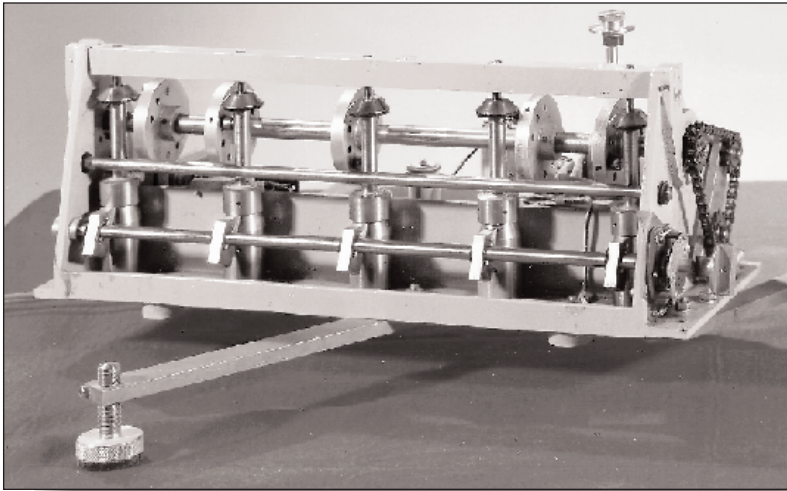

Figure 3.6: Floor tapping machines used for impact insulation ratings

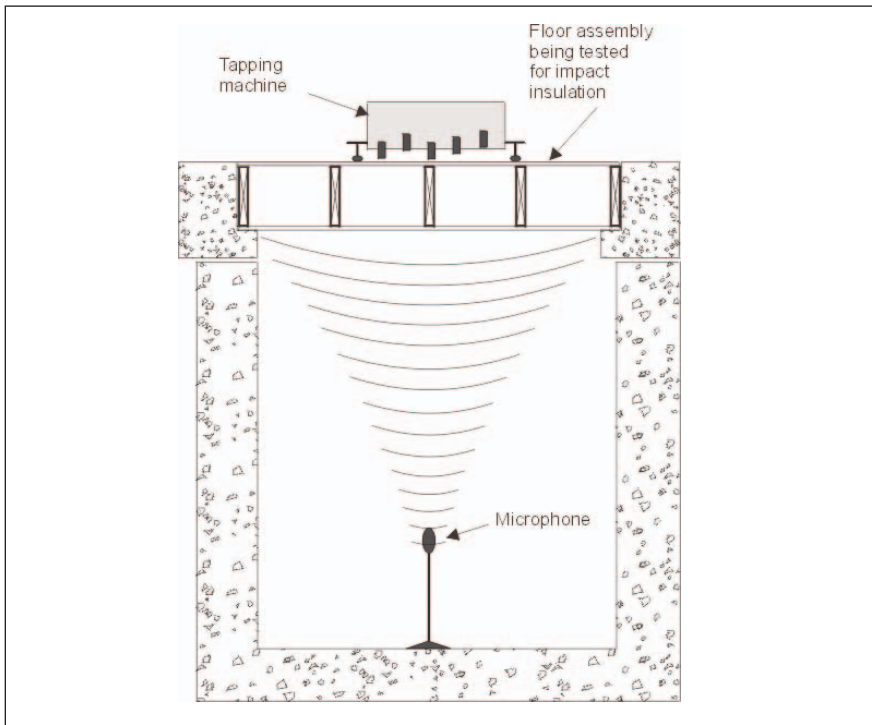

Figure 3.7: Measuring Impact Insulation Class in floor systems

The IIC test method ignores sounds generated at the lower frequencies (below 100 Hz). When people walk on lightweight joist floors, they primarily generate these low-frequency sounds, often at a level below the range used by the IIC rating. Thus, while a low IIC rating indicates that there will be annoyance due to impact sound, a high IIC rating does not necessarily guarantee there will be no problems from low-frequency sound through lightweight floors.

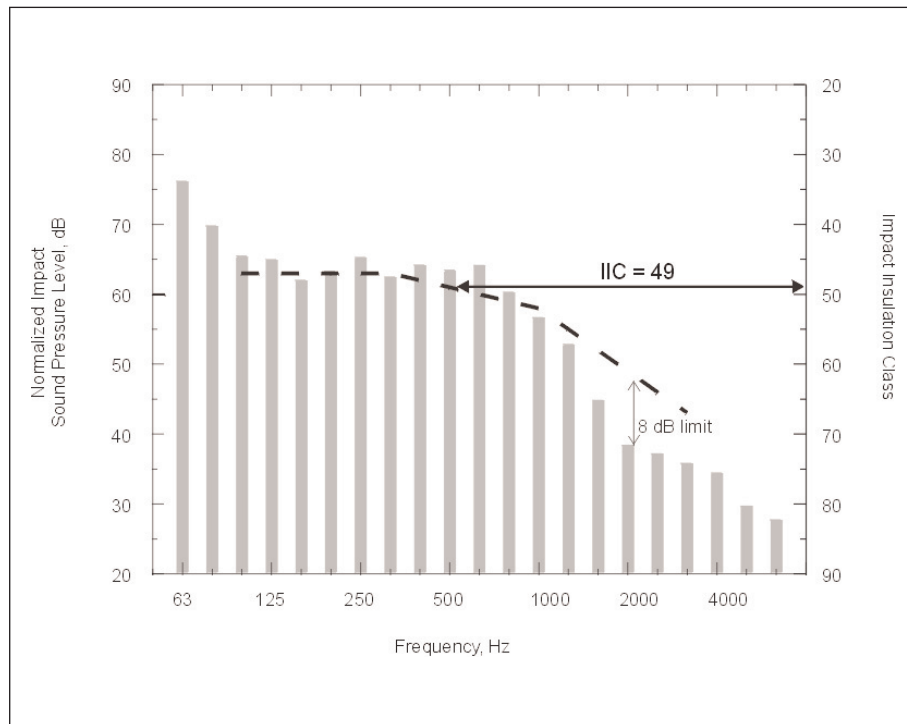

Figure 3.8: Fitting the IIC contour to floor assembly test data

SOUND CONTROL AND THE NATIONAL BUILDING CODE OF CANADA

Currently, the NBCC only regulates airborne sound transmission for the interior wall and floor assemblies in multi-family construction. It does not provide for protection from the transmission of impact sounds. The walls and floors between dwelling units or between dwelling units and adjacent spaces such as stairways, elevator shafts and public corridors must have an STC of 50 or 55 depending on the type of space being separated. Refer to the User's *Guide* to the NBC 1995 Housing and Small Buildings (Part 9) for useful information.

The sound control requirements in the NBCC use the STC rating as the basis for the selection of appropriate assemblies. The excerpt from the NBCC below provides a summary of the requirements from the model code.

A-9.11.1.1. (1) SOUND TRANSMISSION CLASS RATINGS

The specified STC rating of 50 is considered the minimum acceptable value, but many builders prefer to design for STC 55 or more in high quality accommodation.

Another reason to choose assemblies rated higher than STC 50 is that the STC ratings of assemblies are based on laboratory tests, but the sound transmission of any assembly as constructed in the field may be significantly less than its rating. This can be due to sound leaks, departures from design, poor workmanship or indirect (flanking)

transmission paths overlooked in design. To provide a margin of safety to compensate for these, builders often select wall and floor systems that have been rated at least 5 points higher than the design STC rating in laboratory tests.

Sound leaks can occur where one wall meets another, the floor, or the ceiling. Leaks may also occur where the wall finish is cut for the installation of equipment or services. Avoid back-to-back electrical outlets or medicine cabinets. Carefully seal cracks or openings so structures are effectively airtight. Apply sealant below the plates in stud walls, between the bottom of drywall sheets and the structure behind, around all penetrations for services and, in general, wherever there is a crack, a hole or the possibility of one developing. Sound-absorbing material inside a well-designed wall decreases sound transmission. It has another advantage; it also helps to reduce the effects of leaks due, perhaps, to poor workmanship.

Indirect or flanking transmission arises where the parts of a building are rigidly connected together and where cavities in hollow walls or floors, or continuous lightweight layers connect apartments.

Sound travels in cavities, as vibration along surfaces and through walls, ceilings and floors to adjacent rooms. Many paths other than the direct one through the party wall or floor may be involved. To achieve good sound insulation, transmission along flanking paths must be minimized by introducing breaks and resilient connections in the construction. Some examples of bad and good details are shown in the Appendix of the NBCC.

Changes to constructions should not be made without consultation with someone competent in the field of acoustical design. Adding extra layers of drywall to walls in an attempt to reduce sound transmission, can actually increase it if done incorrectly. For example, attaching drywall on resilient channels directly to an existing wall or ceiling usually increases low frequency sound transmission. Adding an additional layer of drywall inside a double layer wall will also seriously increase sound transmission. Adding blocking inside walls to reduce the risk of fire spread should be done so it does not increase vibration transmission from one part of a wall or floor to the other.

To verify that acoustical privacy is being achieved, a field test can be done at an early stage in the construction; ASTM E 336 will give a complete measurement. A simpler and less expensive method is ASTM E 597, "Determining a Single Number Rating of Airborne Sound Insulation in Multi-Unit Building Specifications." The rating provided by this test is usually within 2 points of the STC obtained from ASTM E 336. It is useful for verifying performance and finding problems during construction. Alterations can then be made prior to project completion.

Impact Noise

Section 9.11 has no requirements for control of impact noise transmission. Footstep and other impacts can cause severe annoyance in multi-family residences. Builders concerned about quality and reducing occupant complaints will ensure that floors are designed to minimize impact transmission. A recommended criterion is that bare floors (tested without

a carpet) should achieve an impact insulation class (IIC) of 55. Some lightweight floors that satisfy this requirement may still cause complaints about low frequency impact noise transmission. Adding carpet to a floor will always increase the IIC rating but will not necessarily reduce low frequency noise transmission. Good footstep noise rejection requires fairly heavy floor slabs or floating floors. Impact noise requirements are being considered for inclusion in future versions of the NBCC.

Most frequently used methods of test for impact noise are ASTM E 492, “Laboratory Measurement of Impact Sound Transmission Through Floor-Ceiling Assemblies Using the Tapping Machine,” or ASTM E 1007, “Field Measurement of Tapping Machine Impact Sound Transmission Through Floor-Ceiling Assemblies and Associated Support Structures.”

Machinery Noise

Elevators, garbage chutes, plumbing, fans, and heat pumps are common sources of noise in buildings. To reduce annoyance from these, they should be placed as far as possible from sensitive areas. Vibrating parts should be isolated from the building structure using resilient materials such as neoprene or rubber.

OTHER STANDARDS

Many other standards are used in testing assemblies for their sound attenuation characteristics. The American Society for Testing and Materials (ASTM) publishes a number of key standards listed in Table 3.3 that are used to test and classify building assemblies. These are:

Table 3.3: *ASTM tests used in building acoustics*

E90	Standard method for laboratory measurement of airborne sound transmission loss of building partitions
E336	Standard test method for measurement of airborne sound insulation in buildings
E413	Standard classification for determination of sound transmission class
E492	Standard method of laboratory measurement of impact sound transmission through floor-ceiling assemblies using the tapping machine
E1007	Standard test method for field measurement of impact sound transmission through floor ceiling assemblies and associated support structures
E989	Standard classification for determination of impact insulation class

AUTHORITY HAVING JURISDICTION

While the NBCC and other standards exist across Canada and can be used to provide guidance, the responsibility for accepting specific assemblies and details rests with the provincial or local authority having jurisdiction. Please consult your local building official before choosing a specific assembly or detail, particularly if it is not described by your local building code.

BEST PRACTICES AND MINIMUM RATINGS FOR SOUND CONTROL

The minimum STC required by the NBCC for walls and floors between dwelling units is 50. Walls that separate dwellings from elevator shafts require an STC of at least 55. It should be clear that these are minimum requirements and that in many instances enhanced levels of performance are desired. A good assembly should prevent the passage of noise from all but the most inconsiderate neighbours. While it may not be possible to provide an entirely sound-tight assembly, many walls and floors in the STC 55 to 60 range are quite feasible to construct. Assemblies with an STC 55 generally will provide very good acoustical privacy. Homeowner satisfaction research suggests this level of sound insulation is recommended as a realistic goal to reduce annoyance and disturbance.¹⁸ Where exceptional sound isolation is desired, STC 60 would be a more appropriate rating and would essentially eliminate disturbance from neighbours. It should be understood that in some cases even this rating would not guarantee total protection from low-frequency sound.

Although there is no requirement in the National Building Code for reasonable protection against impact noise, the IIC should be at least 55. As noted, although the rating applies to the whole assembly, the floor covering is extremely important to the IIC rating. Table 3.4 summarizes the minimum recommended STC and IIC requirements for various building assemblies. It should be clear that these exceed the minimums required by the NBCC.

Table 3.4: *Minimum recommended STC and IIC for occupant satisfaction for various structural elements*

Assemblies	NBCC Required STC	Best Practice Recommended STC	Best Practice Recommended IIC
Party walls or corridor walls	50	55	—
Bare party floors	50	55	55
Carpeted party floors	50	55	65
Elevator shafts	55	60	—

¹⁸ Bradley, J.S., "Aggregate Subjective Ratings of Airborne Sound Insulation," Canadian Acoustics, Vol. 27, No. 4, pp. 38–39, (1999).

As an illustrative example, Figure 3.9 shows how carpeting and underpad can improve the IIC of a floor, in this case one made of solid concrete. In this example, the carpet reduces low-frequency sounds by approximately 50 per cent and the high-frequency noise by almost 80 per cent. In this case, the low-frequency sound transmission establishes the final IIC.

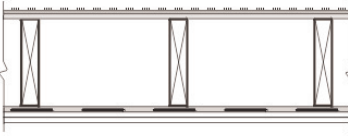
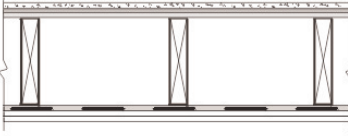
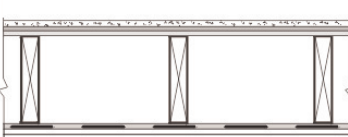
Assembly	Description	Sound Transmission Class ¹	Impact Insulation Class ¹
	<ul style="list-style-type: none"> •10 mm carpet with 5 mm integral foam backing on subfloor of 16 mm plywood on wood joists spaced not more than 400 mm o.c. •Absorptive material in cavity •Resilient metal channels spaced at 600 mm o.c. 	55	65
	<ul style="list-style-type: none"> •19 mm concrete on 3 mm foam rubber on subfloor of 16 mm plywood on wood joists spaced not more than 400 mm o.c. •Absorptive material in cavity •Resilient metal channels spaced at 600 mm o.c. •2 layers of gypsum board on ceiling side 	62	56
	<ul style="list-style-type: none"> •19 mm concrete on 6 mm felt underpad on subfloor of 16 mm plywood on wood joists spaced not more than 400 mm o.c. •Absorptive material in cavity •Resilient metal channels spaced at 600 mm o.c. •2 layers of gypsum board on ceiling side 	63	59

¹ Adapted from: Bradley, C.W., "Sound Performance of Wood/Floor Ceiling Assemblies (Stage II)", CMHC, 1990

Figure 3.9: Sound performance of floating floor assemblies

INTRODUCTION

Controlling the movement of fire and sound from one suite to another is an important function of interior wall assemblies. Occupant safety and comfort can be enhanced by selecting assemblies that provide the performance appropriate for each specific application. In most cases, careful attention to both design and installation will avoid problems that can be costly to remediate.

This chapter provides specific information on the design and installation of wall assemblies to control the movement of both fire and sound. It describes the performance of typical interior wall assemblies, including the impact of electrical, mechanical and plumbing services. The chapter focuses primarily on wood-frame assemblies; although assemblies constructed with concrete and masonry are also discussed as they sometimes are used as party walls or firewalls in wood-frame buildings. Finally, important details that can substantially enhance the performance of interior wall assemblies are provided in the chapter.

CONTROLLING FIRE WITH WALL ASSEMBLIES

As described in Chapter 3, the ability of a wall assembly to resist fire spread is commonly expressed in terms of a fire-resistance rating. The rating identifies the time associated with the failure of the assembly under standard fire exposure conditions during a test. The fire-resistance rating of wall assemblies can be evaluated and compared before the final designs are selected for use within a building. Designers or builders can use three methods to determine the rating for an assembly:

1. Certified or listed assemblies.
2. Assigned ratings.
3. Ratings by calculation.

This chapter shows how each of these methods can be employed to develop fire-resistance ratings for interior wall assemblies. It focuses on assemblies constructed of wood, but also briefly describes those made of concrete and concrete block. In addition, this chapter examines the impact of services and other factors on the fire-resistance of wall assemblies.

FIRE-RESISTANCE OF FRAMED WALL ASSEMBLIES

Framed cavity wall assemblies, for the purposes of this *Guide*, is primarily limited to wood-framed walls protected by gypsum board. However, some discussion is also provided of steel-framed walls, particularly in non-load-bearing applications. Designers and builders should consult the listings of the certification agencies and “Appendix D” of the NBCC for more information on the fire-resistance of cavity walls comprised of two wythes of masonry or two precast panels. In general, the Code considers the two layers of masonry or concrete panels as being additive for fire-resistance rating purposes. The effects of loading and type of masonry or concrete are described in detail in the NBCC.

For wood-framed walls, three methods of determining fire-resistance are available to designers and builders of multi-family buildings: certified or listed assemblies, assigned ratings and ratings by calculation.

CERTIFIED OR LISTED ASSEMBLIES

A large number of wood-framed wall assemblies are listed by certification agencies. Many options are available as aspects of construction are varied including the type, spacing and size of studs, the type and thickness of gypsum board, the type and spacing of fasteners and the type and thickness of insulation. It is important to note that changes to listed assemblies are only permitted where the certification agency has undertaken an assessment of the impact of the changes. Several documents are available that provide guidance on the extrapolation of data from results of fire-resistance tests on proprietary assemblies.^{19,20}

ASSIGNED RATINGS

The committees that develop the National Building Code of Canada have assigned ratings to a wide variety of wood-stud wall assemblies in “Appendix A” of the NBCC. These are shown in Figure 4.1, page 4-3, with specific assemblies that represent best practices identified. It provides ratings for interior wall assemblies with wood studs and gypsum-board membranes, with and without resilient metal channels and insulation. Ratings are also provided for double-stud assemblies on common or separate plates. Rated wood assemblies range from 30 minutes to two hours, depending on their configuration and whether they support load.

¹⁹ “ULC Subject C263(e) M1988 “Criteria for Use in Extension of Data from Fire Endurance Tests.”

²⁰ “ASTM E 2032-99, “Standard Guide for Extension of Data from Fire Endurance Tests.”





Type of Wall	Wall Number	Description	Fire Resistance Rating ⁽¹⁾		Typical Sound Transmission Class ⁽²⁾⁽³⁾
			Load-bearing	Non-Load-bearing	
 <ul style="list-style-type: none"> • Wood Studs • Single Row • Loadbearing or Non-Loadbearing 	W4	<ul style="list-style-type: none"> • 38 x 89 mm studs spaced 400 mm or 600 mm o.c. • 89 mm thick absorptive material⁽⁴⁾ • Resilient metal channels on one side spaced 400 mm or 600 mm o.c. • 2 layers of gypsum board on resilient metal channel side • 1 layer of gypsum board on other side 			
	W4a	<ul style="list-style-type: none"> • W4 with • Studs spaced 400 mm o.c. • 15.9 mm Type X gypsum board⁽⁵⁾ 	1h	1h [1.5h] ⁽⁶⁾	51
	W4b	<ul style="list-style-type: none"> • W4 with • Studs spaced 600 mm o.c. • 15.9 mm Type X gypsum board⁽⁵⁾ 	1h	1h [1.5h] ⁽⁶⁾	54
	W4d	<ul style="list-style-type: none"> • W4 with • Studs spaced 600 mm o.c. • 12.7 mm Type X gypsum board⁽⁵⁾ 	45 min [1h] ⁽⁶⁾	1h	53
 <ul style="list-style-type: none"> • Wood Studs • Single Row • Loadbearing or Non-Loadbearing 	W5	<ul style="list-style-type: none"> • 38 x 89 mm studs spaced 400 mm or 600 mm o.c. • 89 mm thick absorptive material⁽⁴⁾ • Resilient metal channels on one side spaced 400 mm or 600 mm o.c. • 1 layer of gypsum board on resilient metal channel side • 2 layers of gypsum board on other side 			
	W5a	<ul style="list-style-type: none"> • W5 with • Studs spaced 400 mm o.c. • 15.9 mm Type X gypsum board⁽⁵⁾ 	45 min	1h	51
	W5b	<ul style="list-style-type: none"> • W5 with • Studs spaced 600 mm o.c. • 15.9 mm Type X gypsum board⁽⁵⁾ 	45 min	1h	54
	W5d	<ul style="list-style-type: none"> • W5 with • Studs spaced 600 mm o.c. • 12.7 mm Type X gypsum board⁽⁵⁾ 	45 min	1h	53
 <ul style="list-style-type: none"> • Wood Studs • Single Row • Loadbearing or Non-Loadbearing 	W6	<ul style="list-style-type: none"> • 38 x 89 mm studs spaced 400 mm or 600 mm o.c. • With or without absorptive material • Resilient metal channels on one side • 2 layers of gypsum board on each side 			
	 W6a	<ul style="list-style-type: none"> • W6 with • Studs spaced 400 mm or 600 mm o.c. • 89 mm thick absorptive material⁽⁴⁾ • Resilient metal channels spaced 400 mm o.c. • 15.9 mm Type X gypsum board⁽⁵⁾ 	1.5h	2h	55
	 W6b	<ul style="list-style-type: none"> • W6 with • Studs spaced 400 mm or 600 mm o.c. • 89 mm thick absorptive material⁽⁴⁾ • Resilient metal channels spaced 600 mm o.c. • 15.9 mm Type X gypsum board⁽⁵⁾ 	1.5h	2h	58
	W6c	<ul style="list-style-type: none"> • W6 with • Studs spaced 400 mm o.c. • 89 mm thick absorptive material⁽⁴⁾ • Resilient metal channels spaced 400 mm o.c. • 12.7 mm Type X gypsum board⁽⁵⁾ 	1h	1.5h	53
	 W6d	<ul style="list-style-type: none"> • W6 with • Studs spaced 400 mm o.c. • 89 mm thick absorptive material⁽⁴⁾ • Resilient metal channels spaced 600 mm o.c. • 12.7 mm Type X gypsum board⁽⁵⁾ 	1h	1.5h	55
	 W6e	<ul style="list-style-type: none"> • W6 with • Studs spaced 600 mm o.c. • 89 mm thick absorptive material⁽⁴⁾ • Resilient metal channels spaced 400 mm o.c. • 12.7 mm Type X gypsum board⁽⁵⁾ 	1h	1.5h	55

Figure 4.1: Ratings for wall assemblies



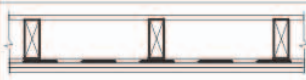
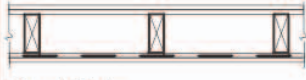
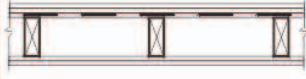







Type of Wall	Wall Number	Description	Fire Resistance Rating ⁽¹⁾		Typical Sound Transmission Class ⁽¹⁾⁽²⁾⁽³⁾
			Load-bearing	Non-Load-bearing	
 <ul style="list-style-type: none"> • Wood Studs • Single Row • Loadbearing or Non-Loadbearing 	W6	<ul style="list-style-type: none"> • 38 x 89 mm studs spaced 400 mm or 600 mm o.c. • With or without absorptive material • Resilient metal channels on one side • 2 layers of gypsum board on each side 			
	 W6f	<ul style="list-style-type: none"> • W6 with • Studs spaced 600 mm o.c. • 89 mm thick absorptive material⁽⁴⁾ • Resilient metal channels spaced 600 mm o.c. • 12.7 mm Type X gypsum board⁽⁵⁾ 	1h	1.5h	58
	W6g	<ul style="list-style-type: none"> • W6 with • Studs spaced 400 mm or 600 mm o.c. • 89 mm thick absorptive material⁽⁴⁾ • Resilient metal channels spaced 400 mm o.c. • 12.7 mm regular gypsum board⁽⁵⁾ 	45 min	1h	50
	W6h	<ul style="list-style-type: none"> • W6 with • Studs spaced 400 mm or 600 mm o.c. • 89 mm thick absorptive material⁽⁴⁾ • Resilient metal channels spaced 600 mm o.c. • 12.7 mm regular gypsum board⁽⁵⁾ 	45 min	1h	52
 <ul style="list-style-type: none"> • Wood Studs • Two Rows Staggered on 38 x 140 mm Plate • Loadbearing or Non-Loadbearing 	W8	<ul style="list-style-type: none"> • (2) rows 38x89 mm studs spaced 400 or 600 mm o.c. staggered on common 38x140 mm plate • 89 mm thick absorptive material on one side or 65 mm thick on each side⁽⁴⁾ • 2 layers of gypsum board on each side • 1 layer of gypsum board on the other side 			
	W8a	<ul style="list-style-type: none"> • W8 with • 15.9 mm Type X gypsum board⁽⁵⁾ 	1h	1.5h	52
	W8b	<ul style="list-style-type: none"> • W8 with • 12.7 mm Type X gypsum board⁽⁵⁾ 	45 min	1h	50
 <ul style="list-style-type: none"> • Wood Studs • Two Rows Staggered on 38 x 140 mm Plate • Loadbearing or Non-Loadbearing 	W9	<ul style="list-style-type: none"> • (2) rows 38x89 mm studs spaced 400 or 600 mm o.c. staggered on common 38x140 mm plate • With or without absorptive material • 2 layers of gypsum board on each side 			
	 W9a	<ul style="list-style-type: none"> • W9 with • 89 mm thick absorptive material on one side or 65 mm thick on each side⁽⁴⁾ • 15.9 mm Type X gypsum board⁽⁵⁾ 	1.5h	2h	56
	 W9b	<ul style="list-style-type: none"> • W9 with • 89 mm thick absorptive material on one side or 65 mm thick on each side⁽⁴⁾ • 12.7 mm Type X gypsum board⁽⁵⁾ 	1h	1.5h	55
	W9c	<ul style="list-style-type: none"> • W9 with • 89 mm thick absorptive material on one side or 65 mm thick on each side⁽⁴⁾ • 12.7 mm regular gypsum board⁽⁵⁾ 	45 min	1h	53
 <ul style="list-style-type: none"> • Wood Studs • Two Rows Staggered on 38 x 140 mm Plate • Loadbearing or Non-Loadbearing 	W10	<ul style="list-style-type: none"> • (2) rows 38x89 mm studs spaced 400 or 600 mm o.c. staggered on common 38x140 mm plate • With or without absorptive material • Resilient metal channels on one side spaced 400 mm or 600 mm o.c. • 2 layers of gypsum board on each side 			
	 W10a	<ul style="list-style-type: none"> • W10 with • 89 mm thick absorptive material on one side or 65 mm thick on each side⁽⁴⁾ • 15.9 mm Type X gypsum board⁽⁵⁾ 	1.5h	2h	62
	 W10b	<ul style="list-style-type: none"> • W10 with • 89 mm thick absorptive material on one side or 65 mm thick on each side⁽⁴⁾ • 12.7 mm Type X gypsum board⁽⁵⁾ 	1h	1.5h	60
	 W10c	<ul style="list-style-type: none"> • W10 with • No absorptive material • 15.9 mm Type X gypsum board⁽⁵⁾ 	1.5h	2h	50

Figure 4.1: Ratings for wall assemblies (continued)









Type of Wall	Wall Number	Description	Fire Resistance Rating ^(a)		Typical Sound Transmission Class ^{(b)(c)}
			Load-bearing	Non-Load-bearing	
 <ul style="list-style-type: none"> • Wood Studs • Two Rows Staggered on 38 x 140 mm Plate • Loadbearing or Non-Loadbearing 	W11	<ul style="list-style-type: none"> • (2) rows 38x89 mm studs spaced 400 or 600 mm o.c. staggered on common 38x140 mm plate • 89 mm thick absorptive material on one side or 65 mm thick on each side^(d) • Resilient metal channels on one side spaced 400 mm or 600 mm o.c. • 2 layers of gypsum board on resilient channel side • 1 layer of gypsum board on other side 			
	 W11a	W11 with • 15.9 mm Type X gypsum board ^(e)	1h	1h	56
	W11b	W11 with • 12.7 mm Type X gypsum board ^(e)	45 min [1h] ^(e)	1h	54
 <ul style="list-style-type: none"> • Wood Studs • Two Rows Staggered on 38 x 140 mm Plate • Loadbearing or Non-Loadbearing 	W12	<ul style="list-style-type: none"> • (2) rows 38x89 mm studs spaced 400 or 600 mm o.c. staggered on common 38x140 mm plate • 89 mm thick absorptive material on one side or 65 mm thick on each side^(d) • Resilient metal channels on one side spaced 400 mm or 600 mm o.c. • 1 layer of gypsum board on resilient metal channel side • 2 layers of gypsum board on other side 			
	 W12a	W12 with • 15.9 mm Type X gypsum board ^(e)	45 min	1h	56
	W12b	W12 with • 12.7 mm Type X gypsum board ^(e)	45 min	1h	54
 <ul style="list-style-type: none"> • Wood Studs • Two Rows on Separate Plates • Loadbearing or Non-Loadbearing 	W13	<ul style="list-style-type: none"> • (2) rows 38x89 mm studs spaced 400 or 600 mm o.c. on separate 38x89 mm plates set 25 mm apart • With or without absorptive material • 1 layer of gypsum board on each side 			
	 W13a	W13 with • 89 mm thick absorptive material on each side ^{(d)(e)} • 15.9 mm Type X gypsum board ^(e)	1h	1h	57
	 W13b	W13 with • 89 mm thick absorptive material on each side ^{(d)(e)} • 12.7 mm Type X gypsum board ^(e)	45 min [1h] ^(e)	45 min [1h] ^(e)	57
	W13c	W13 with • 89 mm thick absorptive material on one side only ^{(d)(e)} • 15.9 mm Type X gypsum board ^(e)	1h	1h	54
	W13d	W13 with • 89 mm thick absorptive material on one side only ^{(d)(e)} • 12.7 mm Type X gypsum board ^(e)	45 min	45 min	53
 <ul style="list-style-type: none"> • Hollow Concrete Block (Normal Weight Aggregate) 	B1	• 140 mm or 190 mm concrete block			
	 B1b	• 190 mm bare concrete block ^(e)	1.5h	1.5h	50

Figure 4.1: Ratings for wall assemblies (continued)

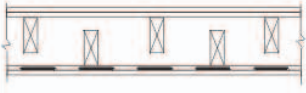

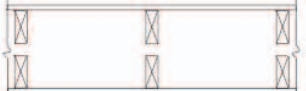
Type of Wall	Wall Number	Description	Fire Resistance Rating ⁽¹⁾		Typical Sound Transmission Class ⁽²⁾⁽³⁾
			Load-bearing	Non-Load-bearing	
 <p>•Hollow Concrete Block (Normal Weight Aggregate)</p>	B2	<ul style="list-style-type: none"> •140 mm or 190 mm concrete block •No absorptive material •1 layer gypsum-sand plaster or gypsum board on each side 			
	B2a	B2 with <ul style="list-style-type: none"> •140 mm concrete block •12.7 mm gypsum-sand plaster 	2h	2h	50
	B2d	B2 with <ul style="list-style-type: none"> •190 mm concrete block •12.7 mm gypsum-sand plaster 	2.5h	2.5h	51
	B2e	B2 with <ul style="list-style-type: none"> •190 mm concrete block •15.9 mm Type X gypsum board⁽⁶⁾ 	3h	3h	50
 <p>•Hollow Concrete Block (Normal Weight Aggregate)</p>	B3	<ul style="list-style-type: none"> •140 mm or 190 mm concrete block •Resilient metal channels on one side spaced at 400 mm or 600 mm o.c. •Absorptive material filling resilient metal channel space⁽⁴⁾ •1 layer gypsum board on each side 			
	B3a	B3 with <ul style="list-style-type: none"> •140 mm concrete block •12.7 mm Type X gypsum board or 15.9 mm Type X gypsum board⁽⁶⁾ 	2h	2h	51
	B3c	B3 with <ul style="list-style-type: none"> •190 mm concrete block •15.9 mm Type X gypsum board⁽⁶⁾ 	3h	3h	54
	B3d	B3 with <ul style="list-style-type: none"> •190 mm concrete block •12.7 mm Type X gypsum board⁽⁶⁾ 	2.5h	2.5h	53
	B3e	B3 with <ul style="list-style-type: none"> •190 mm concrete block •12.7 mm regular gypsum board⁽⁶⁾⁽⁷⁾ 	2h	2h	51
 <p>•Hollow Concrete Block (Normal Weight Aggregate)</p>	B4	<ul style="list-style-type: none"> •140 mm or 190 mm concrete block •Resilient metal channels on each side spaced at 400 mm or 600 mm o.c. •With or without absorptive material •1 layer gypsum board on each side 			
	B4c	B4 with <ul style="list-style-type: none"> •190 mm concrete block •15.9 mm Type X gypsum board⁽⁶⁾ 	3h	3h	50
 <p>•Hollow Concrete Block (Normal Weight Aggregate)</p>	B5	<ul style="list-style-type: none"> •190 mm concrete block •38 mm x 38 mm horizontal or vertical wood strapping on one side spaced at 600 mm o.c. •With or without absorptive material •1 layer gypsum board on each side 			
	B5a	B5 with <ul style="list-style-type: none"> •15.9 mm Type X gypsum board⁽⁶⁾ 	3h	3h	54
	B5b	B5 with <ul style="list-style-type: none"> •12.7 mm Type X gypsum board⁽⁶⁾ 	2.5h	2.5h	53
	B5c	B5 with <ul style="list-style-type: none"> •12.7 mm regular gypsum board⁽⁶⁾⁽⁷⁾ 	2h	2h	51

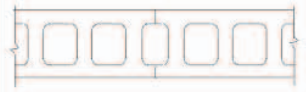
Figure 4.1: Ratings for wall assemblies (continued)





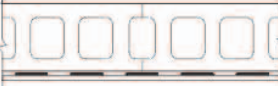





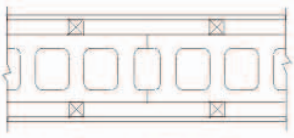





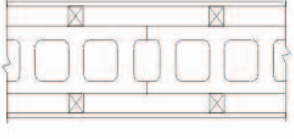

Type of Wall	Wall Number	Description	Fire Resistance Rating ⁽¹⁾		Typical Sound Transmission Class ⁽²⁾⁽³⁾
			Load-bearing	Non-Load-bearing	
 <p>•Hollow Concrete Block (Normal Weight Aggregate)</p>	B6	<ul style="list-style-type: none"> •140 mm or 190 mm concrete block •38 mm x 38 mm horizontal or vertical wood strapping on each side spaced at 600 mm o.c. •Absorptive material filling strapping space on each side⁽⁴⁾ •1 layer gypsum board on each side 			
	 B6a	B6 with <ul style="list-style-type: none"> •140 mm concrete block •12.7 mm or 15.9 mm Type X gypsum board⁽⁵⁾ 	2h	2h	57
	 B6b	B6 with <ul style="list-style-type: none"> •140 mm concrete block •12.7 mm regular gypsum board⁽⁶⁾⁽⁷⁾ 	1.5h	1.5h	56
	 B6c	B6 with <ul style="list-style-type: none"> •190 mm concrete block •15.9 mm Type X gypsum board⁽⁵⁾ 	3h	3h	60
	 B6d	B6 with <ul style="list-style-type: none"> •190 mm concrete block •12.7 mm Type X gypsum board⁽⁵⁾ 	2.5h	2.5h	59
	 B6e	B6 with <ul style="list-style-type: none"> •190 mm concrete block •12.7 mm regular gypsum board⁽⁶⁾⁽⁷⁾ 	2h	2h	57
 <p>•Hollow Concrete Block (Normal Weight Aggregate)</p>	B8	<ul style="list-style-type: none"> •190 mm concrete block •38 mm x 64 mm wood studs on each side spaced at 600 mm o.c. •Absorptive material filling stud space on each side⁽⁴⁾ •1 layer gypsum board on each side 			
	 B8a	B8 with <ul style="list-style-type: none"> •15.9 mm Type X gypsum board⁽⁵⁾ 	3h	3h	71
	 B8b	B8 with <ul style="list-style-type: none"> •12.7 mm Type X gypsum board⁽⁵⁾ 	2.5h	2.5h	70
	 B8c	B8 with <ul style="list-style-type: none"> •12.7 mm regular gypsum board⁽⁶⁾⁽⁷⁾ 	2h	2h	69
 <p>•Hollow Concrete Block (Normal Weight Aggregate)</p>	B9	<ul style="list-style-type: none"> •190 mm concrete block •50 mm metal Z-bars on each side spaced at 600 mm o.c. (or 38 mm x 38 mm horizontal or vertical wood strapping plus resilient metal channels) •Absorptive material filling Z-bar space on each side⁽⁴⁾ •1 layer gypsum board on each side 			
	 B9a	B9 with <ul style="list-style-type: none"> •15.9 mm Type X gypsum board⁽⁵⁾ 	3h	3h	65
	 B9b	B9 with <ul style="list-style-type: none"> •12.7 mm Type X gypsum board⁽⁵⁾ 	2.5h	2.5h	64
	 B9c	B9 with <ul style="list-style-type: none"> •12.7 mm regular gypsum board⁽⁶⁾⁽⁷⁾ 	2h	2h	63
 <p>•Hollow Concrete Block (Normal Weight Aggregate)</p>	B10	<ul style="list-style-type: none"> •190 mm concrete block •Resilient metal channels on one side spaced at 600 mm o.c. •Absorptive material filling resilient metal channel space⁽⁴⁾ •2 layers gypsum board on one side only 			
	 B10a	B10 with <ul style="list-style-type: none"> •15.9 mm Type X gypsum board⁽⁵⁾ 	3h	3h	56
	 B10b	B10 with <ul style="list-style-type: none"> •12.7 mm Type X gypsum board⁽⁵⁾ 	2.5h	2.5h	55
	 B10c	B10 with <ul style="list-style-type: none"> •12.7 mm regular gypsum board⁽⁶⁾⁽⁷⁾ 	2h	2h	54

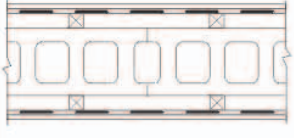
Figure 4.1: Ratings for wall assemblies (continued)

- (1) Fire resistance and STC ratings of wood frame construction were evaluated only for 38 mm x 89 mm construction. The fire resistance ratings and STC ratings provided for 38 mm x 89 mm wood frame construction, however, may be applied to 38 mm x 140 mm wood frame construction; in some cases the ratings may be conservative. Where 38 x 140 mm framing is used and absorptive material is called for, the absorptive material must be 140 mm thick.
- (2) Sound ratings listed are based on the most reliable laboratory test data available for specimens conforming to installation details required by CSA-A82.31, "Gypsum Board Application." Results of specific tests may differ slightly because of measurement precision and minor variations in construction details. These results should only be used where the actual construction details, including spacing of fasteners and supporting framing, correspond exactly to the details of the test specimens on which the ratings are based. Assemblies with sound transmission class ratings of 50 or more require acoustical sealant applied around electrical boxes and other openings, and at the junction of intersecting walls and floors, except intersection of walls constructed of concrete or solid brick.
- (3) Sound ratings are only valid where there are no discernible cracks or voids in the visible surfaces. For concrete blocks, surfaces must be sealed by at least 2 coats of paint or other surface finish described in Section 9.29. of the NBCC (e.g., gypsum board) to prevent sound leakage.
- (4) Sound absorptive material includes fibre processed from rock, slag, glass or cellulose fibre. It must fill at least 90% of the cavity thickness for the wall to have the listed STC value. The absorptive material should not overfill the cavity to the point of producing significant outward pressure on the finishes; such an assembly will not achieve the STC rating.
- (5) The complete descriptions of indicated finishes are as follows:
 - 12.7 mm regular gypsum board—12.7 mm regular gypsum board conforming to Article 9.29.5.2. of the NBCC (see below).
 - 12.7 mm Type X gypsum board—12.7 mm special fire-resistant Type X gypsum board conforming to Article 9.29.5.2. of the NBCC (see below).
 - 15.9 mm Type X gypsum board—5.9 mm special fire-resistant Type X gypsum board conforming to Article 9.29.5.2. of the NBCC (see below).
 - Except for exterior walls (see Note 2), the outer layer of finish on both sides of the wall must have its joints taped and finished.
 - Fastener types and spacing must conform to CSA-A82.31, "Gypsum Board Application."
 - NBCC 9.29.5.2. Materials: Gypsum products shall conform to (a) CAN/CSA-A82.27-M, "Gypsum Board," (b) ASTM C 36, "Gypsum Wallboard," (c) ASTM C 37, "Gypsum Lath," (d) ASTM C 442, "Gypsum Backing Board and Coreboard," (e) ASTM C 588, "Gypsum Base for Veneer Plaster," (f) ASTM C 630, "Water Resistant Gypsum Board Backing," (g) ASTM C 931, "Exterior Gypsum Soffit Board," or (h) ASTM C 960, "Predecorated Gypsum Board."
- (6) Absorptive material required for the higher fire-resistant rating is mineral fibre processed from rock or slag with a mass of at least 4.8 kg/m² for 150 mm thickness, 2.8 kg/m² for 89 mm thickness and 2.0 kg/m² for 65 mm thickness and completely filling the wall cavity. For assemblies with double wood studs on separate plates, absorptive material is required in the stud cavities on both sides.
- (7) Regular gypsum board used in single layer assemblies must be installed so all edges are supported.
- (8) Where bracing material, such as diagonal lumber or plywood, OSB, gypsum board or fibreboard sheathing is installed on the inner face of one row of studs in double stud assemblies, the STC rating will be reduced by 3 for any assemblies containing absorptive material in both rows of studs or in the row of studs opposite to that to which the bracing material is attached. Attaching such layers on both inner faces of the studs may drastically reduce the STC value but enough data to permit assignment of STC ratings for this situation is not available. The fire resistance rating is not affected by the inclusion of such bracing.

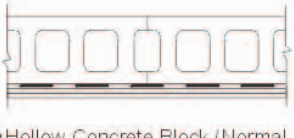
Notes to Figure 4.1 (adapted from 1995 National Building Code)

RATINGS BY CALCULATION

Mathematical modelling techniques for calculating the fire endurance of framed-wall assemblies are beginning to emerge. Research in recent years has led to the development of mathematical models of the heat transfer through wood-framed walls under fire exposure conditions. The effects of structural loading on these assemblies is only now beginning to be incorporated into the mathematical models. Qualified fire safety engineers should be consulted if this method of determining ratings is to be used.

“Appendix D” of the NBCC details a calculation technique called the “component additive method,” which can be used to establish the rating of an assembly. This method adds together assigned time periods associated with each of the components of the wall assembly, the sum of which is the assigned fire-resistance rating for the entire assembly. The contributions to fire-resistance of each of the components were derived from a review of fire tests that began well over a half century ago. The steps involved in the “component additive method” are summarized below:

- Table 4.1 identifies the time assigned to membranes attached to the fire-exposed side (facing the furnace) of the wall assembly. The ratings are based on the membrane staying in place during the fire test.

Table 4.1: Time assigned to wallboard membranes on fire-exposed side (from NBCC, 1995)

Description of finish	Time in minutes
11.0 mm (7/16 in.) Douglas Fir plywood phenolic bonded	10*
14.0 mm (9/16 in.) Douglas Fir plywood phenolic bonded	15*
12.7 mm (1/2 in.) Type X gypsum wallboard	25
15.9 mm (5/8 in.) Type X gypsum wallboard	40
Double 12.7 mm (1/2 in.) Type X gypsum wallboard	80†
* Non-load-bearing walls only, stud cavities filled with mineral wool insulation.	
† Applies to non-load-bearing steel-framed walls only.	

- Table 4.2 identifies the contributions of the wall frame. The time assigned represents how long the frame can withstand fire attack after the fire-exposed membrane falls off.

Table 4.2: Time assigned for contribution of wood-frame (from NBCC, 1995)

Description of frame	Time in minutes
Wood studs 400 mm (16 in.) o.c. maximum	20
Wood studs 600 mm (24 in.) o.c. maximum	15

Cavity Insulation

Mineral fibre insulation typically refers to insulation made from glass, rock or slag.

Mineral wool insulation refers specifically to insulation made from rock or slag.

Gypsum Board and Fire Resistance Ratings

Adding an extra layer of Type X gypsum board can increase the fire resistance rating of a wall by 55%.

Based on tests of two 38 x 89 mm (2 x 4 inch) loadbearing walls with single layer both sides and double layer both sides of 12.7 mm (1/2 inch) Type X gypsum wallboard on resilient channels and cavity filled with glass fibre insulation.

Reference:

Sultan, M.A., Loughheed, G.D., Monette, R.C., MacLaurin, J.W., and Denham, E.M.A., "Temperature Measurements in Full-Scale Insulated Gypsum Board-Protected Wall Assemblies with Resilient Channels", NRC Internal Report 676, 1994.

- The third step in the calculation method is to consider the contribution to the fire-resistance arising from the use of insulation in the wall cavity. Mineral wool insulation (rock or slag with a mass not less than 1.22 kg/m² (0.25 lbs/ft²) is assigned a time of 15 minutes as its contribution to the fire-resistance of wood-stud walls. Glass fibre insulation (with a mass not less than 0.6 kg/m² (0.12 lbs/ft²)) is assigned five minutes in non-load-bearing wood stud walls only. When insulation is tightly fitted between studs, it tends to protect the sides of the studs from fire attack for a period of time.
- Adding each of the contributions together determines the overall fire-resistance rating of the assembly. No contribution is included for the membrane on the non-fire-exposed side (away from the furnace) since it is assumed that it will fail at the same time as the framing members.

Limitations for the component additive method include:

- A maximum rating of 90 minutes is permitted using this method.
- Wood studs are considered to be both load-bearing and non-load-bearing.
- Multiple layers of gypsum board are permitted only where specified in Table 4.1, page 4-9.
- Cellulose fibre insulation does not contribute to the fire-resistance of assemblies.
- Wood studs are assumed to be no less than 38 mm x 89 mm (2 in. x 4 in. nominal).
- Gypsum wallboard edges are supported with minor exceptions (implying additional support for wallboard applied horizontally).
- Membranes are fastened as detailed in "Appendix D," NBCC, both in terms of spacing of fasteners and depth of penetration. Fastener spacing for double-layer construction must conform to CSA 82.31-M, "Gypsum Board Application." See Figure 4.2, page 4-11.

This simplified method of calculation provides designers and builders with a means to determine fire-resistance of generic assemblies. The component additive method was completely revised in the 1995 NBCC from its original form, which was developed in the 1960s. Consequently, the variety of wall assemblies that can be assigned fire-resistance ratings using this technique is now very limited.

However, between 1990 and 1995 significant research work was undertaken at NRC to look at a variety of wood-stud wall assemblies to determine whether or not the traditional fire-resistance rating values were still valid. The fire-resistance ratings listed for the assemblies described in Figure 4.1, page 4-3, verified that the generic ratings developed using the component additive method are still valid.

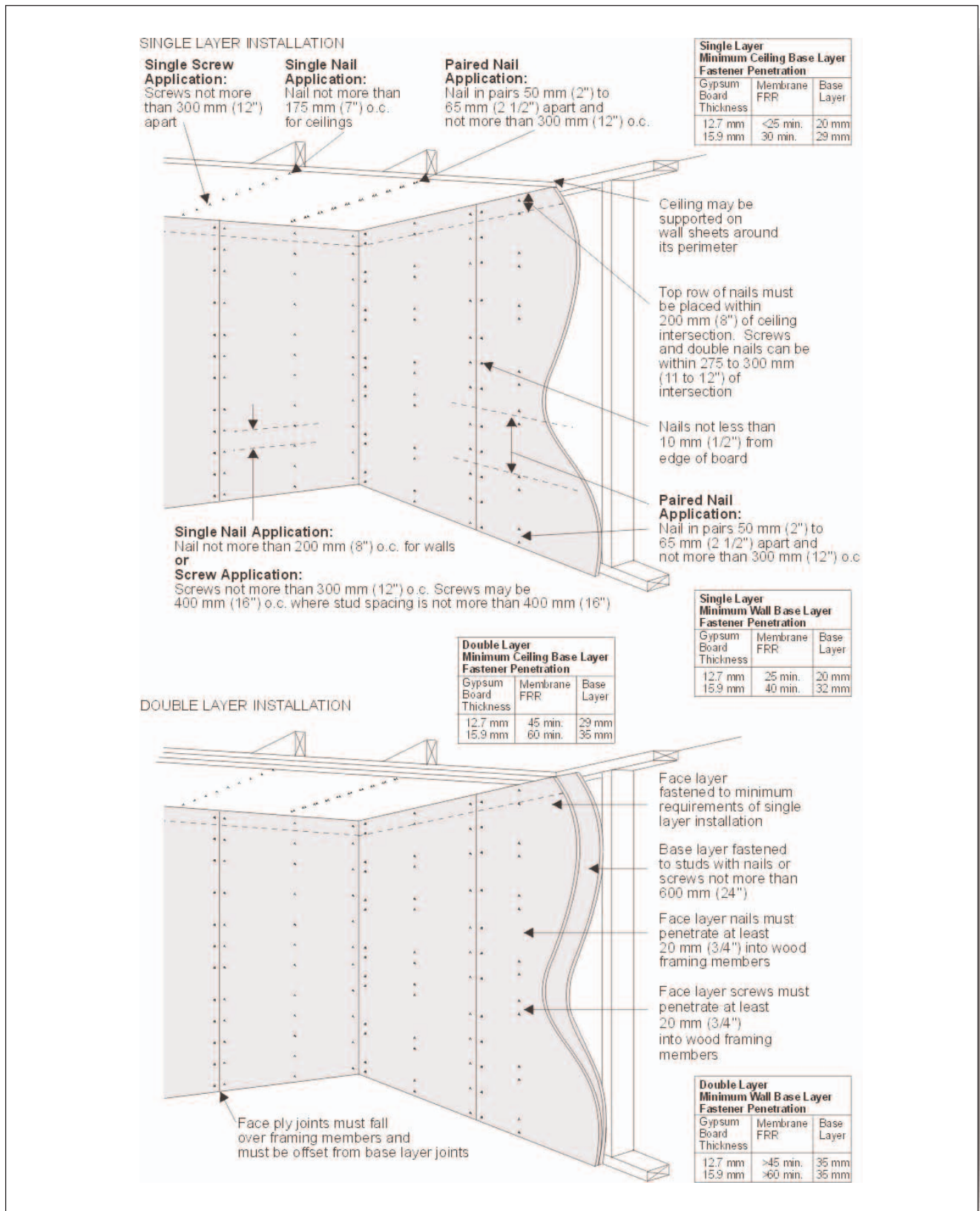

Figure 4.2: Nail and screw fastening for gypsum board

FIRE-RESISTANCE OF CONCRETE-BLOCK WALLS

While the focus of this Guide is wood-frame construction in multi-family buildings, there are often situations where concrete or concrete-block firewalls are used to divide large wood-frame buildings into smaller individual buildings to avoid having to use non-combustible construction for the entire building. Also, using firewalls to divide the structure into smaller buildings allows a designer to use a prescriptive framing approach (allowed by Part 9 of the NBCC) rather than engineered structural systems (required by Part 4 of the NBCC). In addition to being used as firewalls, concrete-block walls are also often used to enclose elevator shafts incorporated in some low-rise multi-family building designs. Finally, some builders choose concrete-block walls to use as party walls between dwellings due to personal preference and experience.

Like wood-stud wall assemblies, the fire-resistance ratings for concrete-block walls may be determined by certification, assigned ratings or calculations. This section discusses these various approaches. Three methods of determining fire-resistance are available to designers and builders of multi-family buildings.

CERTIFIED OR LISTED ASSEMBLIES

Some companies manufacturing concrete blocks have submitted their products for evaluation by recognized certification agencies and have received certification reports and listings. These are typically included in the agencies' publications, showing the type and thickness of block and the fire-resistance rating.

ASSIGNED RATINGS

Assigned fire-resistance ratings for single-wythe, concrete-block walls range from 1 h. for a bare 140 mm (6 in.) thick concrete-block wall to 3 h. for a 190 mm (8 in.) thick concrete-block wall with gypsum board and insulation on both sides (see Figure 4.1, page 4-3). It should be noted that when concrete-block or masonry walls are used as firewalls in MFBs, the NBCC requires that the fire-resistance rating be a minimum of 2 h. and that the fire-resistance rating be provided entirely by the masonry or concrete block with no credit for the gypsum board or insulation. Fortunately, this is easily achieved. Like the numerous listings for wood stud wall assemblies in Figure 4.1, page 4-3, the extensive listings for concrete-block walls provide other useful alternatives available to designers and builders to meet the fire-resistance requirements for multi-family buildings.

RATINGS BY CALCULATION

There are two means by which fire-resistance ratings for concrete-block walls can be calculated. One involves the use of detailed engineering equations for heat transfer coupled with structural engineering. This is seldom used due to its complexity. The other is to use the calculation method described in "Appendix D" of the NBCC.

The method described in "Appendix D" uses the concept of "equivalent thickness" of concrete to determine fire-resistance ratings. Equivalent thickness is essentially the equivalent amount of solid material that is available in the block wall when the voids (block cells) are excluded.

It is calculated by measuring the actual thickness of the concrete block and multiplying it by the ratio of the net volume to the gross volume of the unit. Net volume is the actual volume of concrete (gross volume less the voids), while the gross volume is calculated from the overall exterior dimensions of the block unit. This method provides a relatively simple means to determine fire-resistance. “Appendix D” of the NBCC provides sample calculations that illustrate how to use this method to determine fire-resistance ratings.

Per cent solid values (used to calculate equivalent thickness) and wall fire-resistance ratings are nearly always available directly from producers of concrete masonry units for the various block types manufactured.

Factors that affect fire-resistance using the equivalent thickness concept include:

- The type of concrete used for manufacturing the blocks.
- Whether the core spaces are filled with grout or loose fill materials.
- The presence and type of plaster or gypsum board applied to the faces of the concrete-block wall and the type of plaster or gypsum board.

“Appendix D” of the NBCC provides additional guidance on the effect of these factors on the determination of fire-resistance ratings. Fire-resistance of solid-concrete walls

Fire-resistance ratings for solid-concrete walls may be determined by certification or by calculation. Like concrete-block walls, solid-concrete walls are usually finished with a plaster or gypsum board surface, which contributes to the fire-resistance of the assembly. As well, solid-concrete walls used in multi-family buildings typically fail by temperature rise on the unexposed face rather than by structural failure or flame-through.

CERTIFIED OR LISTED ASSEMBLIES

Some proprietary, solid-concrete walls have been tested and listed by certification agencies. These are typically walls incorporating different types of aggregates or features not recognized in “Appendix D” of the NBCC. Designers and builders of multi-family buildings may select these for specific applications.

ASSIGNED RATINGS

The committees that develop the National Building Code of Canada have assigned ratings to solid-concrete walls for use under the Code. These are shown in “Appendix A” of the NBCC.

RATINGS BY CALCULATION

The vast majority of solid-concrete walls have their fire-resistances determined using calculation methods. As with concrete-block walls, the designer or builder can undertake a comprehensive analysis using engineering equations (for example, as contained in the American Society of Civil Engineers manual, *Structural Fire Protection*²¹) or by applying the method described in “Appendix D” of the NBCC. The former method is usually undertaken by a qualified fire safety engineer.

²¹ Lie, T.T., “Structural Fire Protection,” American Society of Civil Engineers, New York, NY, 1992.

Solid-concrete walls are not necessarily solid from face to face but may be hollow core, precast concrete panels. The fire-resistance rating of this type of panel is calculated using the method of equivalent thickness described above for concrete-block walls. Where such panels are tapered, “Appendix D” describes how to determine the equivalent thickness. Where the concrete panel is essentially “solid,” the designer or builder should refer to the calculation from “Appendix D” of the NBCC. See Table 4-3.

Factors that affect the fire-resistance of solid-concrete walls include:

- The presence of core spaces.
- The presence of panel tapering.
- The type and strength of concrete.
- The presence and type of plaster or gypsum board applied to the faces of the wall.
- Whether the wall may be exposed to fire from both sides simultaneously (such as an interior wall wholly within one apartment).

Table 4.3: *Fire-resistance and monolithic load-bearing and non-load-bearing concrete wall thicknesses in millimetres (from NBCC, 1995)*

Type of wall	Fire-resistance rating						
	1/2 h	3/4 h	1 h	1.5 h	2 h	3 h	4 h
Monolithic concrete and concrete panels, equivalent thickness							
Type S concrete	60 mm	77 mm	90 mm	112 mm	130 mm	158 mm	180 mm
Type N concrete	59 mm	74 mm	87 mm	108 mm	124 mm	150 mm	171 mm
Type L40S or L concrete	49 mm	62 mm	72 mm	89 mm	103 mm	124 mm	140 mm

IMPACT OF INTEGRATING SERVICES ON FIRE-RESISTANCE

Very little information, either experimental or empirical, is available on the impact of electrical, plumbing or air-handling systems or services on the fire-resistance of wall assemblies. There are a few proprietary solutions published for certain listed assemblies by the certification agencies. However, there is little data to which the designer or builder can refer when these services pass through or penetrate wall assemblies having fire-resistance ratings that have either been assigned generically or calculated.

The NBCC requires that pipes, ducts, electrical outlet boxes or other similar service equipment that penetrate an assembly have a fire-resistance rating and be non-combustible unless tested to prove performance. Exceptions to this general rule are:

- Optical fibre cables and electrical wire and cables need not be non-combustible, provided they are enclosed in a non-combustible raceway.
- Certain non-metallic raceways, optical fibre cables and electrical wire and cables up to 25 mm (1 in.) in diameter, single or grouped, may penetrate the assembly.

- Single conductor, metal sheathed cables with combustible jacketing more than 25 mm (1 in.) in diameter may penetrate the assembly provided they are not grouped.
- Small combustible outlet boxes with an opening through the membrane less than 0.016 m² (24 sq. in.) are permitted. All boxes must be offset on opposite sides of the assembly and sealed with acoustical sealant.
- When a wall assembly is required to be constructed as a fire separation, with or without a fire-resistance rating, combustible sprinkler piping may penetrate the assembly provided the rooms or spaces on both sides of the wall are protected by sprinklers.
- Combustible water distribution piping may penetrate the assembly provided the pipe has an outside diameter of not more than 30 mm (1-3/16 in.) and the space around the pipe is sealed by an approved fire stop system.
- Some combustible drain, waste and vent piping that has been specially tested is permitted.
- Combustible drain, waste and vent piping that penetrates only one membrane of a cavity wall assembly that is not a vertical shaft is acceptable.
- In most cases, steel ducts equipped with fire dampers may penetrate the rated assembly.

While eliminating penetrations with fire and acoustical separations is always preferred, with these requirements and exceptions, assemblies with integrated services can be constructed without significantly affecting the fire-resistance rating of the assembly. It should be clear that integrated services might, on the other hand, compromise the sound-performance characteristics of the assembly. These issues are explored in the pages to come.

SOUND CONTROL AND WALL ASSEMBLIES

WALL DESIGN PRINCIPLES

Wall assemblies designed to attenuate sound should incorporate:

- Two layers that are not connected at any point by solid materials and that provide a degree of airtightness.
- The heaviest layers that are practical.
- The deepest cavity that is practical, filled with sound-absorbing material.

Two heavy layers will impede the movement of sound energy across the assembly. Also, avoiding solid connections between the layers forces the sound to travel through the cavity and interact with the sound-absorbing material. Solid connections allow the sound to travel from one face of the wall to the other and bypass the sound-absorbing materials in the cavity.

For discussion, wall assemblies have been grouped into two broad categories: **framed walls** and **masonry and concrete walls**. Each of these is detailed below.

**Short-Circuiting
Resilient Channels**

Any contact of gypsum board screws to the studs or joists as the gypsum board is attached to the resilient channels can significantly increase sound transmission through the assembly and reduce the effectiveness of the resilient channels.

Reference:

Nightingale, T.R.T., "Study of Flanking Sound Transmission in Wood Framed Construction", CMHC, 1993.

**SOUND CONTROL
WITH FRAMED WALLS**

Introducing a cavity within the wall is an important step towards attenuating sound. Wood-framed walls provide a simple approach to this type of construction. Following some simple guidelines increases the likelihood that the walls will provide a suitable level of performance and protect occupants from unwanted sound from adjacent units.

To attenuate sound effectively, ideally, no rigid contacts should exist between the gypsum wallboard and the structural framing members within the wall. The use of resilient supports to attach the gypsum wallboard is a practical approach to reducing the rigid connection that exists in typical wood-frame walls and to reducing the sound transmission through studs. In general, the farther apart the studs are spaced the better. Similarly, the farther apart the resilient supports the better.

Table 4.4, page 4-18, provides STC ratings for various wood-frame stud walls. The values presented in this table are not measured values for individual samples, but are estimates based on many tests conducted at the NRCC and other laboratories.

Using independent or double rows of studs is often recommended to provide a generous cavity that can accommodate sound-absorbing material. Typically filling a wall cavity with sound-absorbing materials like batt insulation can increase sound transmission loss often by eight to 10 dB if the layers are properly isolated.

Staggered studs can provide similar advantages to walls constructed using double, independent rows of studs. This type of construction consists of a wider top and bottom plate, 38 x 140 mm (2 x 6 in.) or 38 x 184 mm (2 x 8 in.), supporting 38 x 89 mm (2 x 4 in.) studs normally spaced along each edge of the plates to support the gypsum wallboard on each side of the wall assembly. Adjacent studs alternate between one face of the assembly and the other. Sound is able to easily travel through bottom and top plates across the cavity, but not easily through the studs since they do not penetrate the full width of the cavity. See Figure 4.3, page 4-17.

The use of resilient metal channels can help to isolate the gypsum wallboard layers from the other components in a wood-stud wall, such as the wood-framing and sound-absorbing insulation materials. In specific applications, if used appropriately, other resilient materials may also be used, including wood fibreboard and rigid-glass fibreboard.

Figure 4.1, page 4-3, derived from the NBCC, shows a wide variety of assemblies with the corresponding STC for each.

**SOUND CONTROL WITH
MASONRY AND CONCRETE WALLS**

As discussed earlier, when masonry and concrete construction is used in wood-frame multi-family buildings, it is most often used for firewalls. Firewalls are used to divide large buildings into smaller, individual wood-frame multi-family buildings to avoid using non-combustible construction for the entire building.

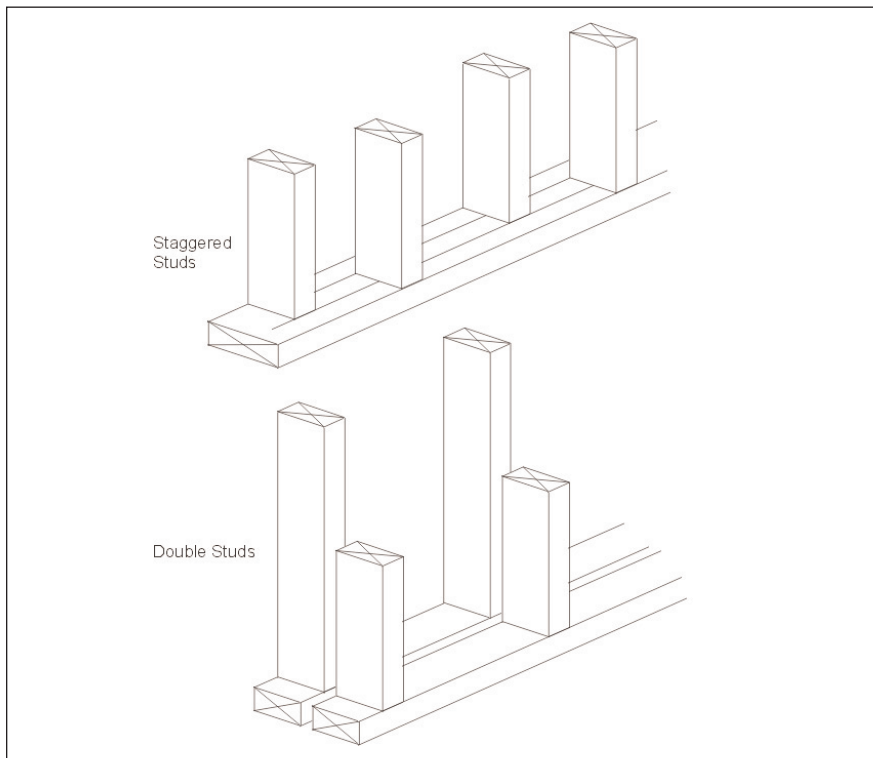

Figure 4.3: Staggered studs vs. double studs

Like wood-stud wall assemblies, the sound transmission of the masonry and concrete walls are affected by a number of system characteristics.

SINGLE-WYTHE CONCRETE-BLOCK CONSTRUCTION

For concrete-block masonry, the weight of the assembly has the strongest effect on sound attenuation. Single-wythe concrete-block masonry walls provide STC ratings between 45 and 55, provided the masonry surface is sealed. Table 4.5, page 4-19, identifies the typical STC rating for single-wythe concrete-block walls constructed with hollow units. The actual STC rating is dependent upon the density of the block unit and the percentage of solid material. Measured STC ratings will vary slightly between laboratories.

Filling the core of the blocks with sand or grout can improve the transmission loss by increasing the mass of the blocks. Adding sound-absorbing materials in the cores will not increase the sound insulation, since the sound transmission is primarily through the structure of the block.

Normally, getting an STC rating much greater than 50 with single-wythe walls requires the use of normal-weight block construction. Alternatively, as will be subsequently shown, adding gypsum board mounted on studs or furring will markedly improve STC and minimize weight.

Depending on the block density, sealing the surface of the concrete block with plaster or block-sealer paint can significantly improve the sound insulation it provides. Lightweight blocks tend to be more porous than normal-weight blocks. The more porous the block, the greater the improvement in transmission loss when the block is sealed. The STC of lightweight blocks may be improved

Table 4.4: Test-Derived STC ratings for frame walls

STC for wall with 15.9 mm (5/8") Type X gypsum board—density about 11.2 kg/m ² (2.29 lbs/ft ²)	Layers of gypsum board			
	Stud arrangement	1&1	1&2	2&2
38 x 89 mm (2 x 4 in) wood studs 400 mm (16 in) o.c.		34	36	38
38 x 89 mm (2 x 4 in) wood studs 600 mm (24 in) o.c. + RC 400 or 600 mm (16 or 24 in) o.c.		50	54	58
38 x 89 mm (2 x 4 in) wood studs 400 mm (16 in) o.c. + RC 400 mm (16 in) o.c.		43	50	56
38 x 89 mm (2 x 4 in) wood studs 400 mm (16 in) o.c. + RC 600 mm (24 in) o.c.		46	53	59
38 x 140 mm (2 x 6 in) wood studs at 600 mm (24 in) o.c. + RC 600 mm (24 in) o.c.		53	57	59
Staggered 38 x 89 mm (2 x 4 in) wood studs 400 mm (16 in) o.c.		49	52	56
Staggered 38 x 89 mm (2 x 4 in) wood studs 400 mm (16 in) o.c. + RC 600 mm (24 in) o.c.		51	56	62
STC values for 12.7 mm (1/2") Type X gypsum board (density about 9.5 kg/m ²) (1.95 lbs/ft ²)	Layers of gypsum board			
Stud arrangement	1&1	1&2	2&2	
38 x 89 mm (2 x 4 in) wood studs 400 mm (16 in) o.c.	34	37	38	
38 x 89 mm (2 x 4 in) wood studs 600 mm (24 in) o.c. + RC 400 or 600 mm (16 or 24 in) o.c.	46	51	57	
38 x 89 mm (2 x 4 in) wood studs 400 mm (16 in) o.c. + RC 400 mm (16 in) o.c.	42	49	55	
38 x 89 mm (2 x 4 in) wood studs 400 mm (16 in) o.c. + RC 600 mm (24 in) o.c.	45	51	58	
38 x 140 mm (2 x 6 in) wood studs at 600 mm (24 in) o.c. + RC 600 mm (24 in) o.c.	49	54	59	
RC 600 mm (24 in) o.c.	47	50	55	
Staggered 38 x 89 mm (2 x 4 in) wood studs 400 mm (16 in) o.c. + RC 600 mm (24 in) o.c.	49	54	60	

(From CMHC's Sound Transmission Through Gypsum Board Walls. Values in this table may differ from those of the NBCC. Builders and designers should consult their local building officials where use of these values is proposed. All cavities filled with sound-absorbing material (glass fibre). Staggered stud walls are constructed with common top and bottom plates; double-row stud walls have two rows of studs on separate top and bottom plates. Resilient channels are only installed on one side beneath the double gypsum board layer in the 1&2 and 2&2 cases.)

by five to 10 dB when the surface is sealed. Conversely, normal-weight blocks usually show little or no improvement after sealing. The improvement in STC is related to the airflow resistivity of the blocks, a characteristic that can be—but rarely is—measured.

As noted earlier, supporting gypsum board on furring or studs at a distance from the surface of a block wall can provide large gains in sound insulation. There are three important factors to consider:

1. The method of support.
2. The distance from the surface of the blocks to the rear face of the gypsum board.
3. The use of sound-absorbing material in the cavity between the gypsum board and the block surface.

If the furring supporting the gypsum board is rigid, sound may travel directly through it from the gypsum board to the blocks. The transmission of sound can be attenuated if the furring is sufficiently resilient or if the gypsum board is supported using standoff studs. Resilient metal furring may be used on its own or in combination with wood furring.

Best practice involves:

- Providing a cavity between the block wall and gypsum board that is as large as practical and as necessary to attain an acceptable STC rating.
- No connections at all to the block by using standoff studs to support the gypsum board.
- Adding sound-absorbing material to the cavity between the board and the block. (Note that closed cell materials such as expanded polystyrene, do not significantly absorb sound).

Table 4.5: Typical STC ratings for single-wythe concrete-block walls with hollow, sealed units

Thickness, mm (in.)	Lightweight (not less than 50% solid)		Normal weight (not less than -50% solid)	
	kg (lbs)/ block	STC	kg (lbs)/ block	STC
90 (4)	8 (17.6)	42	10 (22.1)	44
140 (6)	10 (22.1)	44	15 (33.1)	46
190 (8)	14 (30.9)	48	18 (39.7)	50
240 (10)	17 (37.5)	48	21 (46.3)	50
290 (12)	20 (44.1)	49	25 (55.1)	51

(From Warnock, A.C.C., “Sound Transmission Loss Measurements Through 190 mm and 140 mm Blocks with Added Gypsum Board and Through Cavity Block Walls,” Internal Report 586, IRC).

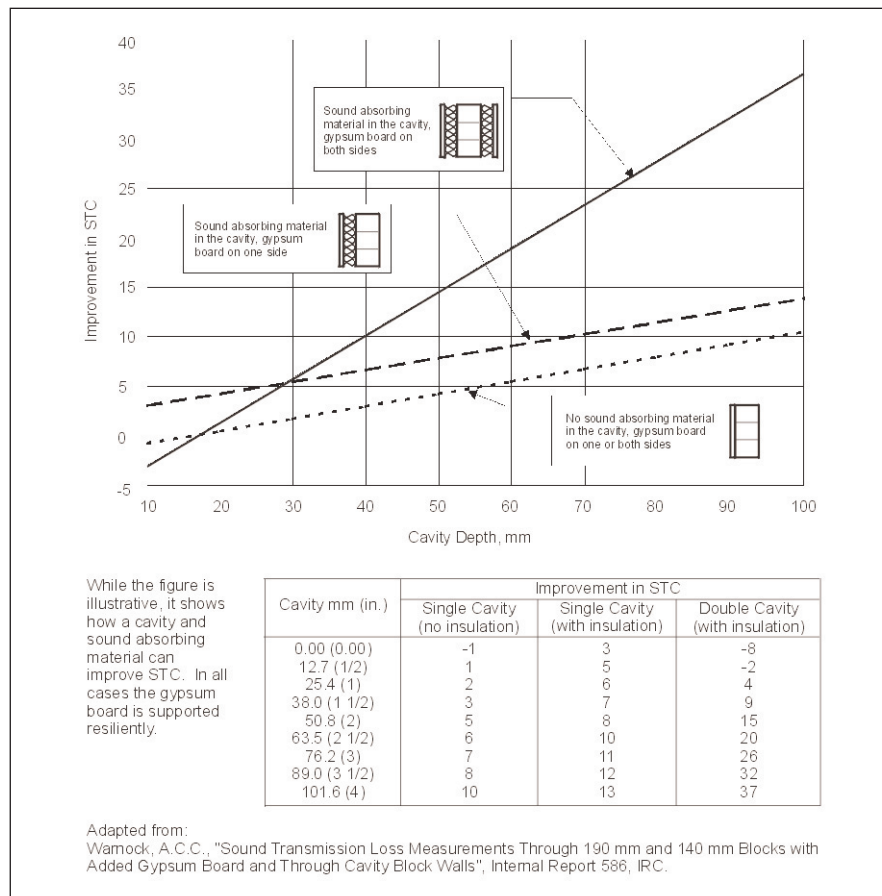

Figure 4.4: Estimating STC improvement for block walls

Data from an extensive series of measurements on normal weight block walls was used to develop an empirical method for predicting sound transmission class for normal-weight block walls with gypsum board supported on resilient furring or on independent studs.^{22, 23, 24, 25} Figure 4.4 gives the improvement in the STC over the bare block assembly and may be used without serious error for single layers of 12.7 mm (1/2 in.) or 15.9 mm (5/8 in.) thick gypsum board. The values derived from the figure can be added directly to the STC of the bare block assembly. (Noted in Table 4.5, page 4-22).

The leakage of sound through a more porous, lightweight concrete block can be used to advantage when gypsum board is added to finish the wall. Because sound penetrates the block, the effective depth of the cavity is greater than the distance from the rear face of the gypsum board to the block surface to an

- 22 Warnock, A.C.C. and Monk, D.W., "Sound Transmission Loss of Masonry Walls: Tests on 90, 140, 190, 240 and 290 mm Concrete Block Walls with Various Surface Finishes," Building Research Note 217, IRC, 1984.
- 23 Northwood, T.D. and Monk, D.W., "Sound Transmission Loss of Masonry Walls: Twelve-inch Lightweight Concrete Blocks-Comparison of Latex and Plaster Sealers," Building Research Note 93, IRC, 1974.
- 24 Northwood, T.D. and Monk, D.W., "Sound Transmission Loss of Masonry Walls: Twelve-inch Lightweight Concrete Blocks with Various Surface Finishes," Building Research Note 90, IRC, 1974.
- 25 Warnock, A.C.C., "Sound Transmission Loss Measurements Through 190 mm and 140 mm Blocks with Added Gypsum Board and Through Cavity Block Walls," Internal Report 586, IRC.

extent that depends on the block porosity. The recommended approach to finishing a porous block is as follows:

- Apply plaster or block sealer on one side only. If a gypsum board finish is required on this side, it should be glued or screwed on directly.
- On the second side of the wall, use resilient metal furring or independent studs to support a layer of gypsum board. Put sound-absorbing material in the cavity. As for normal weight blocks, the larger the cavity depth the better.

Lightweight block walls finished in this manner can provide STCs as good as those provided by heavier blocks. Currently, it is not possible to predict the STC for composite walls such as these. Approximate estimates may be obtained using the procedures for normal weight blocks; however, measurement of the sound transmission loss values may be called for where this construction is used. In some cases, these practices have yet to be recognized by building codes. A full discussion with the local building official is always recommended.

Refer to Figure 4.1, page 4-3, for the STC for a variety of masonry wall assemblies.

DOUBLE-WYTHE MASONRY CAVITY BLOCK WALLS

Double-wythe masonry block cavity walls are similar to double wood-stud framed party walls in that the double-wythe system can provide very high sound insulation. They also resemble the ideal wall assembly: two independent heavy layers separated by a cavity. The increase in sound transmission loss relative to a single-layer wall with the same total weight is considerable. STC ratings for this type of construction are shown in Table 4.6, page 4-22. It is interesting to see that, even in heavier construction of the type shown in the table, sound-absorbing material, when installed in the air cavity between wythes, provides additional sound insulation benefits.

In practice, constructing two block walls that are structurally isolated—not solidly connected somewhere—requires some forethought. Sound can be transmitted along masonry ties, along the floor, ceiling and walls abutting the periphery of the double-wythe wall and through other parts of the structure that can impair sound insulation. Flexible ties and physical breaks in the floor, ceiling, and abutting walls can reduce this flanking transmission. Mortar droppings (fins) or other debris can also bridge the gap and increase sound transmission (see Figure 4.5, page 4-22). This is particularly true where cavities are less than 40 mm (1-1/2 in.). These types of design and construction oversights, in general, are usually concealed and nearly impossible to fix after the wall is complete. In one laboratory test, a cavity wall that was expected to attain an STC greater than 70, only provided STC 60 because of mortar fins that connected the two wythes of the wall. Like other wall systems, good design, care in construction and skilled supervision are needed to achieve optimal performance.

Table 4.6: STC ratings for structurally isolated, block-cavity walls

Thickness of first block layer—normal weight, 50% solid	Cavity	Thickness of second block layer—normal weight, 50% solid	STC
190 mm (8 in.)	65 mm (2-1/2 in.) glass fibre panels in 135 mm (5-1/2 in.) air space	90 mm (4 in.) split rib	79
90 mm (4 in.)	65 mm (2-1/2 in.) glass fibre panels in 125 mm (5 in.) air space	90 mm (4 in.) split rib	77
90 mm (4 in.)	50 mm (2 in.) expanded polystyrene panels in 125 mm (5 in.) air space	90 mm (4 in.) split rib	69
90 mm (4 in.)	125 mm (5 in.) air space	90 mm (4 in.) split rib	69

From Warnock, A.C.C., "Sound Transmission Loss Measurements Through 190 mm and 140 mm Blocks with Added Gypsum Board and Through Cavity Block Walls," Internal Report 586, IRC.

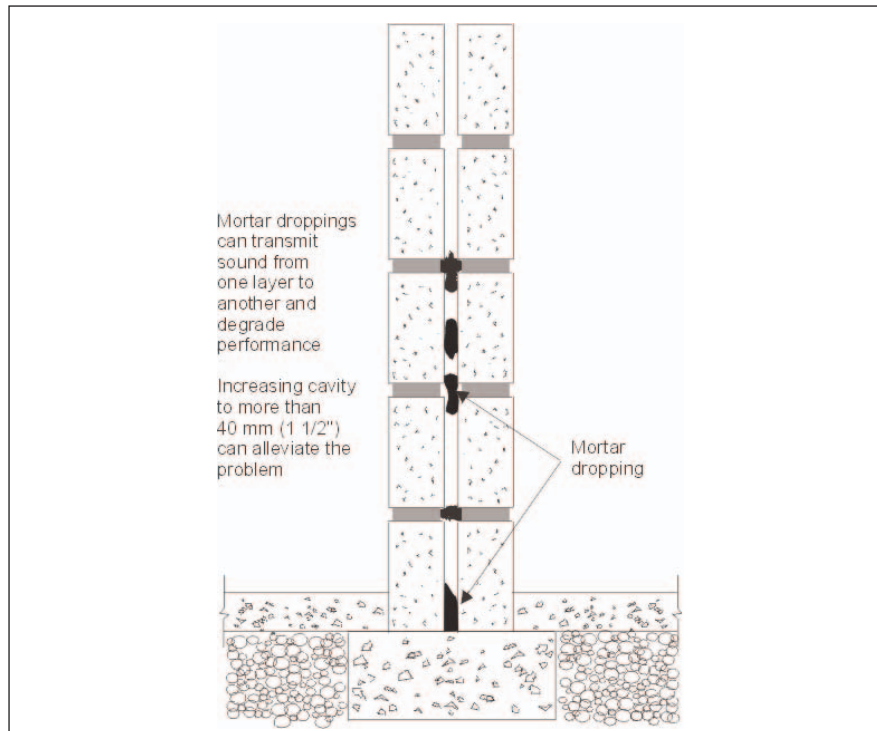

Figure 4.5: Debris between wythes of concrete blocks

CONCRETE WALLS

Generally, the weight required to achieve an STC of 55 is likely to be prohibitive in wood-frame buildings (remember that mass must be doubled for an increase of 6 dB). The usual solution where high STC ratings are needed is to use multi-layer partitions—a central massive wall with one or more leaves, typically of gypsum board, attached to each side.

For solid concrete, STC is determined by density, thickness and stiffness of the material. Fortunately, in normal construction these properties do not vary substantially. Table 4.7 gives representative STC values for some common concrete assemblies. Concrete walls, typically, can provide STCs from about 45 to 55.

Table 4.7: STC for solid-concrete construction

Thickness	Mass, kg/m ² (lbs/ft ²)	STC
50 mm (2 in.)	115 (23.6)	43
70 mm (3 in.)	161 (33.0)	46
100 mm (4 in.)	230 (47.1)	48
150 mm (6 in.)	345 (70.7)	53
200 mm (8 in.)	460 (94.2)	56

The same principles that apply to the design of multi-layer block walls also apply to solid concrete; namely, increasing the cavity depth, adding absorptive material and using independent or resilient supports for the gypsum board. The same methods used to estimate the STC for block walls may be used for concrete walls.

Occasionally, poured concrete walls may have voids from improper practices. All voids need to be carefully patched. Covering the concrete with gypsum board, even if the edges are caulked, will not prevent sound from leaking through the assembly.

INTEGRATING SERVICES TO AVOID UNWANTED SOUND

A number of best practices are available to reduce the likelihood of the installation of electrical, mechanical and plumbing services causing undesirable sources of noise. The following lists the most common items that left unattended can cause noise.

Electrical services

- Light switches and outlets must not be constructed back-to-back. Where possible they should be offset at least 400 mm (16 in.). See Figure 4.6, page 4-24.
- Sound insulation should extend behind electrical outlets.
- Ceiling fixtures where possible should be surface mounted and openings around the boxes sealed airtight.
- Electrical panels, telephone, doorbell, intercom and built-in audio must not be installed on walls separating suites or on corridor walls.
- Separate wiring to each suite is recommended to avoid sound transmission through wiring between outlets installed in walls.

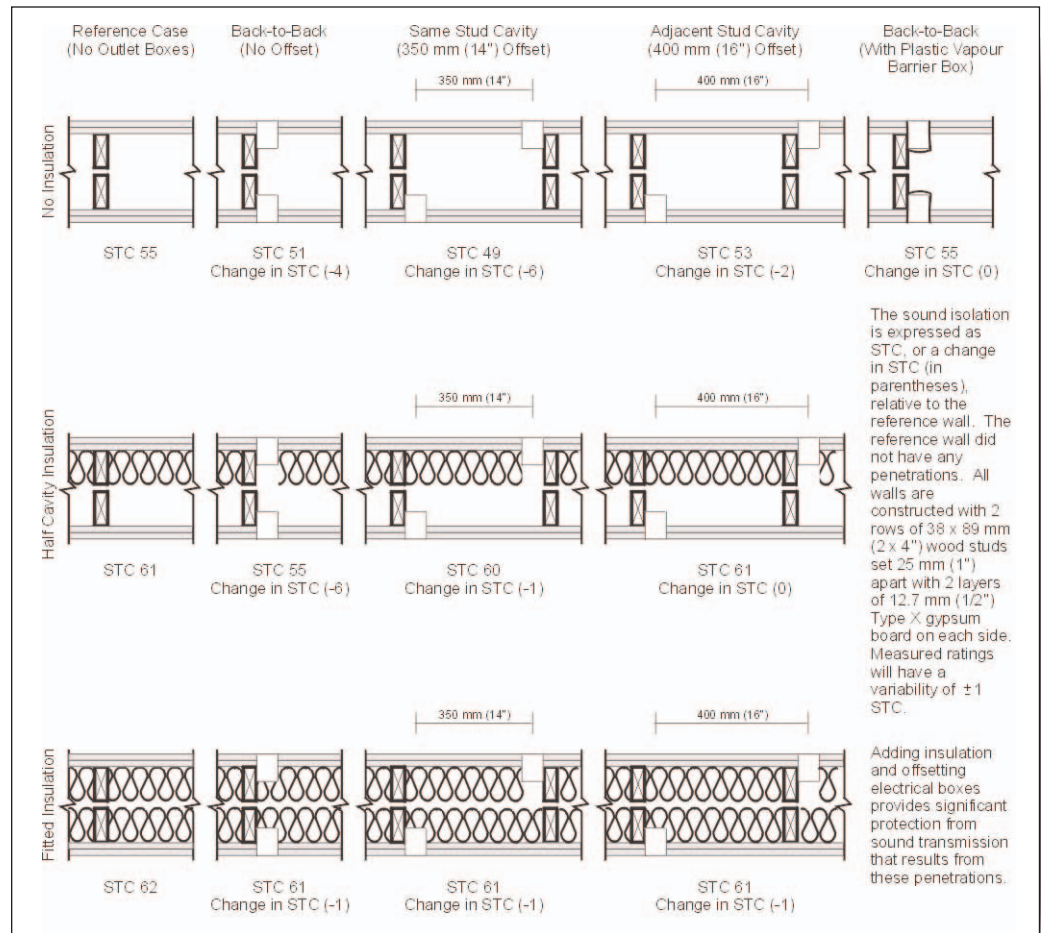

Figure 4.6: Double-stud construction and the location of electrical outlet boxes

- Where wiring is installed to equipment that vibrates, flexible wiring should be used.

Heating, cooling and ventilating ducts

- Oversized and undersized heating, cooling and ventilating equipment can cause unnecessary noise. Proper equipment sizing is essential.
- Use duct wrap material to reduce sidewall transmission and fan noise in the duct.
- Use good quality, quiet equipment where possible. Sound-isolate furnaces, air conditioners and HVAC units. Use vibration isolators where necessary.

Plumbing

- Pipe runs should be installed with hangers or resilient sleeves so expansion and contraction can occur without binding.
- Piping should be isolated from surrounding structures with resilient pads. See Figure 4.7, page 4-25.
- Air chambers should be provided at each outlet to eliminate water hammer due to the abrupt stopping of the flowing water.
- Oversized pipes and reduced water pressures should be utilized, where possible.
- All penetrations must be caulked.

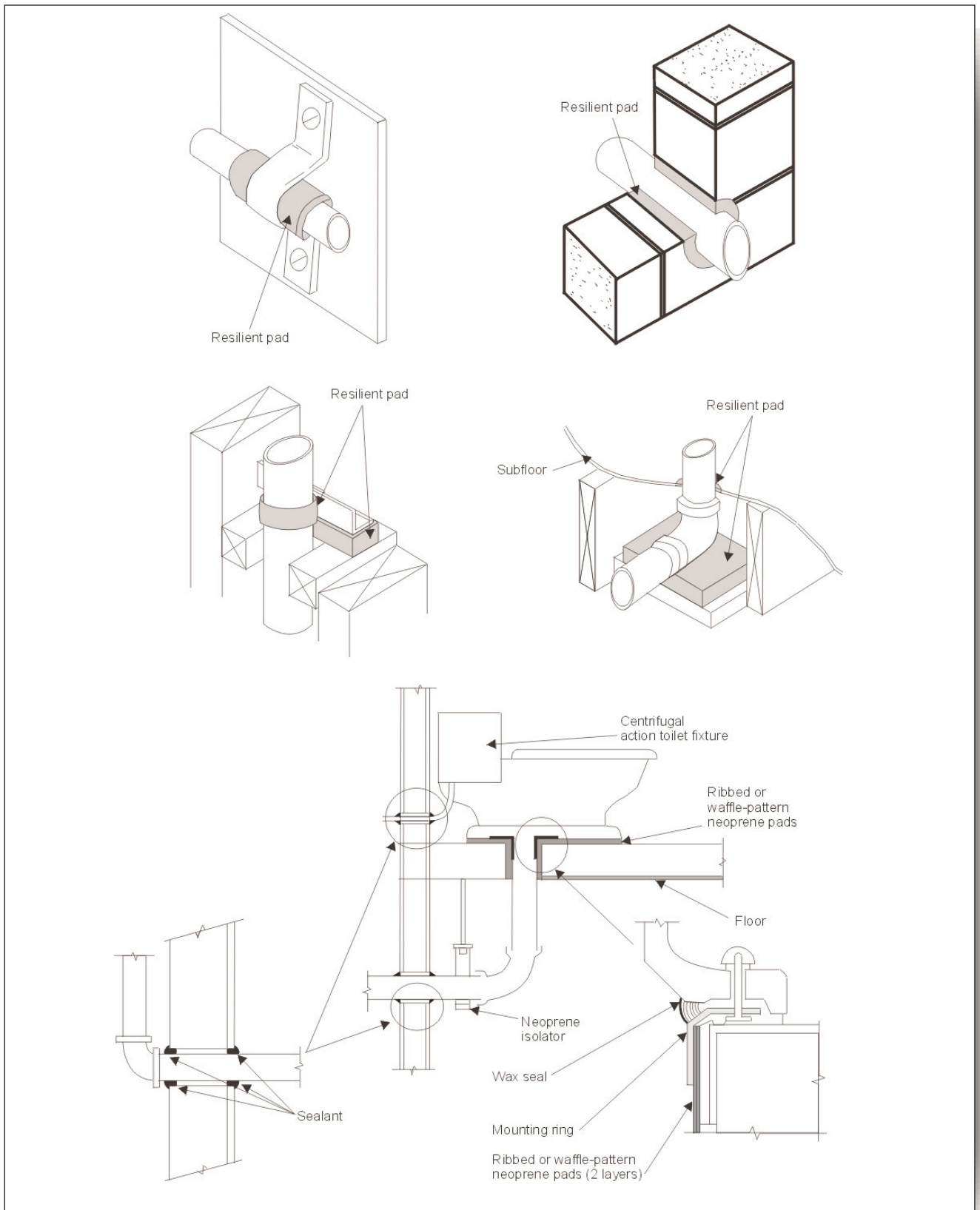

Figure 4.7: Electrical and plumbing services reduce noise and occupant discomfort

ASSEMBLING AND INTEGRATING COMPONENTS TO AVOID UNWANTED SOUND

UNDER-BOTTOM PLATE SEALING

Applying two beads of a non-hardening acoustical sealant, such as a butyl rubber-based compound, under the bottom plate of the frame wall will reduce the transmission of sound leaking through the assembly and flanking around it. See Figure 4.8. Any debris under the plate should be cleared away prior to sealing. Debris impairs effective sealing. See Figure 4.9, page 4-27.

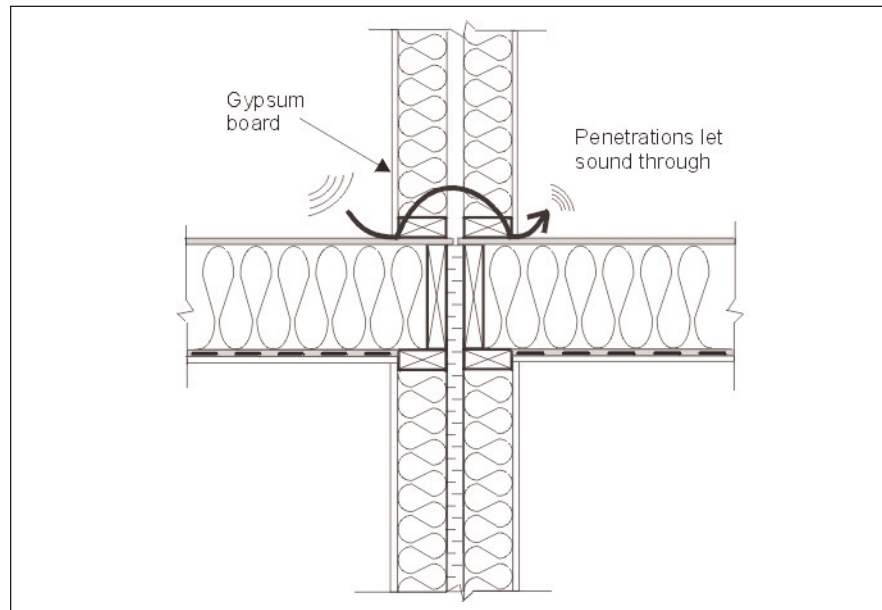

Figure 4.8: Penetration of sound through cracks in a framed wall

PERIMETER SEALING

An air seal should be used around the perimeter of walls to reduce the sound transmission through the assembly. A non-hardening, permanently resilient caulking is required for both sides of the partition at the bottom and top plates. Even small holes can seriously affect the performance of the wall. The bottom and top of drywall applied over block or solid-concrete walls must also be sealed. See Figure 4.10, page 4-27.

SEALING BLOCK WALL AND CONCRETE WALLS

Concrete block that is not covered with drywall must be sealed with block-sealer paint, plaster or parging. Where block walls are covered with drywall, they should be left unfinished beneath the drywall since the porous block will provide additional sound-absorbing benefits. It should be noted that the current version of the NBCC requires all block surfaces to be sealed in all cases. Consult your local building official.

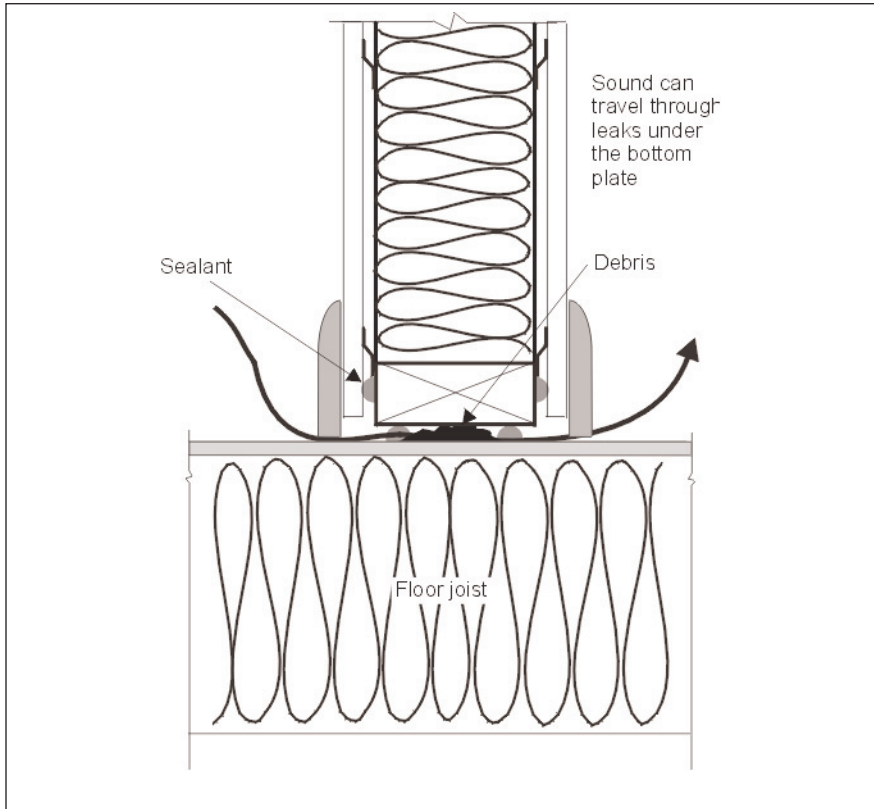

Figure 4.9: Sound leak caused by debris under the sole plate

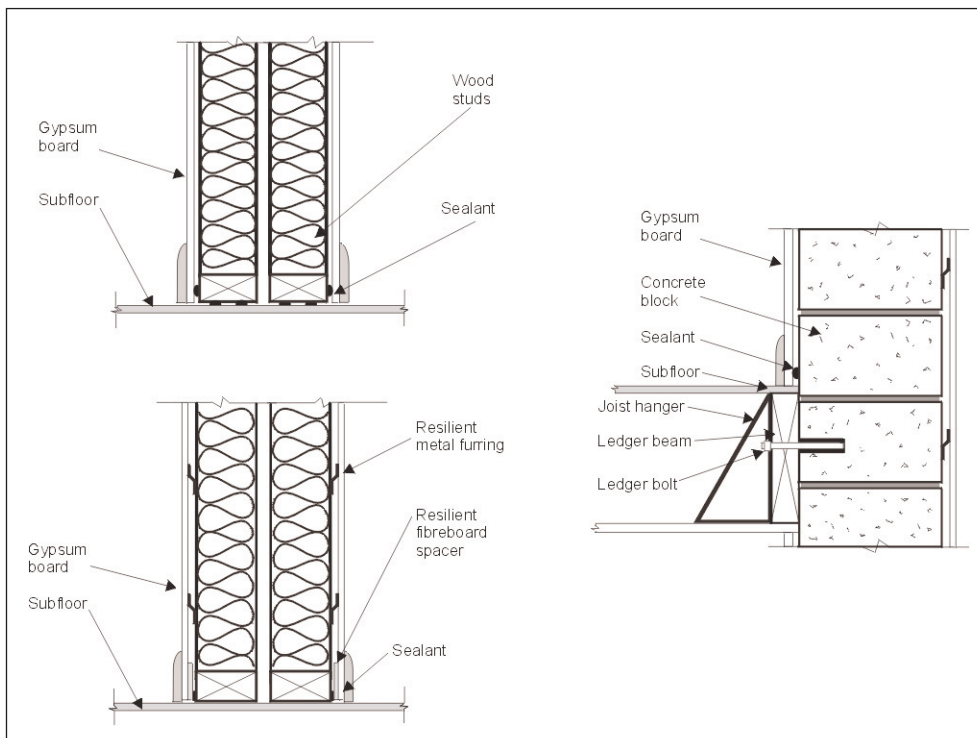

Figure 4.10: Application of sealant to prevent sound leaks

All holes or honeycombing in concrete walls and all holes in concrete-block walls must be patched with appropriate cementitious material. Bare concrete walls must be painted. If covered by drywall, they should be left unpainted.

DRYWALL SCREWS AND RESILIENT LAYERS

Where resilient channels or other resilient materials are used, avoid using drywall screws that are too long and that can short-circuit the resilient material. Screws used to attach gypsum wallboard that penetrate the studs will transmit sound through the assembly and negate the benefits of the resilient materials.

PLACING LAYERS WITHIN CAVITIES CAN REDUCE SOUND INSULATION

When the internal cavity of the wall is quite deep, adding a layer of drywall, plywood or other sheathings within the cavity can reduce the STC of the wall. Figure 4.11 shows the effect of the additional drywall layer.

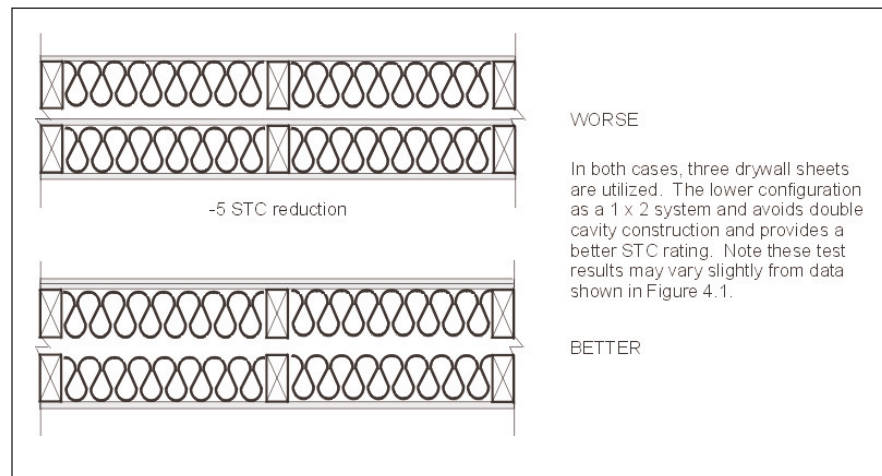

Figure 4.11: Sound transmission and double cavities

FLANKING NOISE THROUGH WALLS

Figure 4.12, page 4-29, shows how flanking transmission can occur where party walls meet external walls or corridor walls in multi-family buildings. It also shows how a break can be introduced to disrupt the flanking path along the outer wall. Careful construction can introduce a break in the flanking path but maintain a continuous inner surface to control air leakage. The gap left between the gypsum board sheets is caulked with acoustical caulking to preserve a continuous air barrier while still giving a construction break for acoustical control. In some cases large gaps may need to be sealed with contractor sheathing tape.

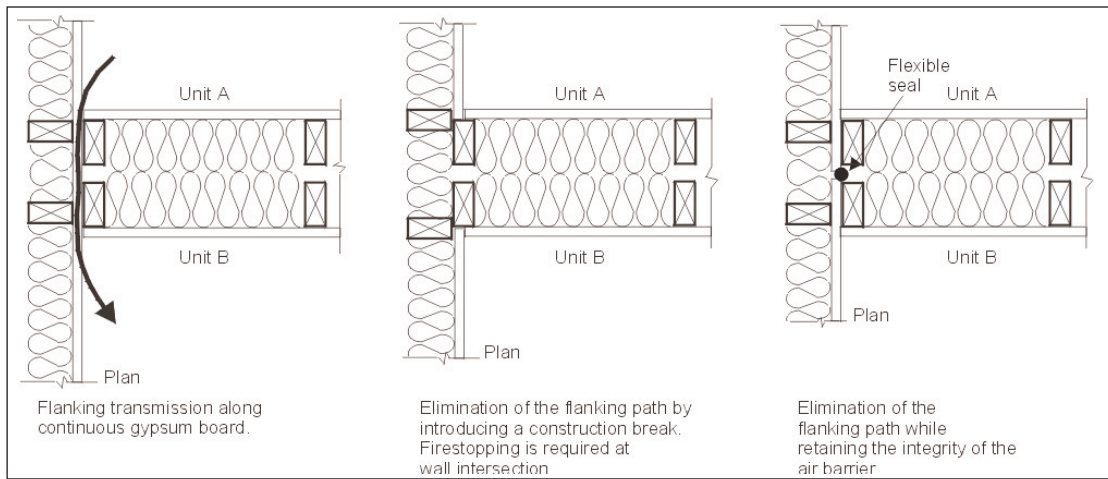
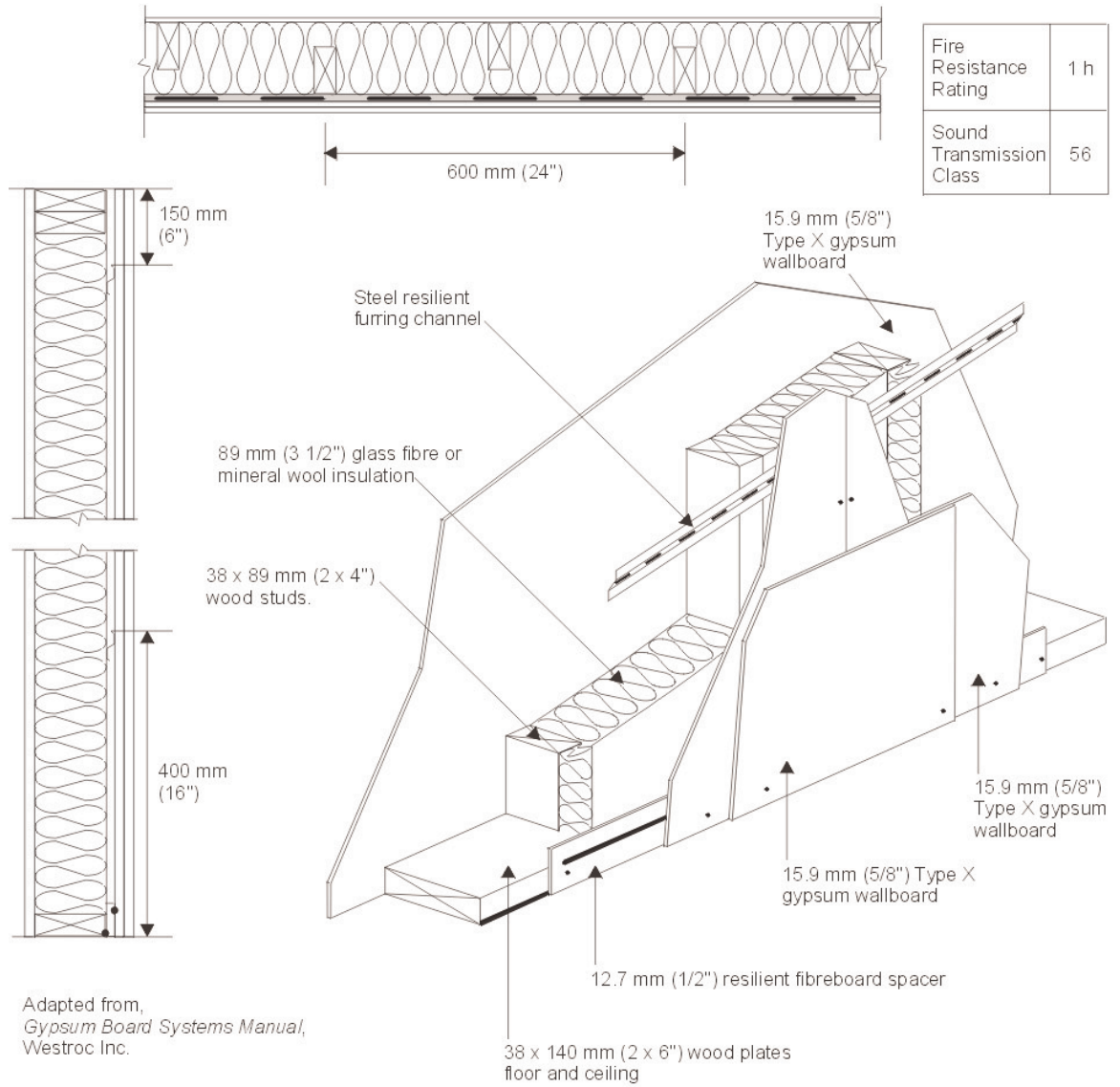

Figure 4.12: *Eliminating flanking transmission path in walls*

Although generally not part of interior walls separating suites in multi-family buildings, doors are important components that can contribute to sound transmission in buildings. Solid wood doors tend to perform better in controlling noise. Door tops and sides should be gasketed with a soft-type weatherstripping. Threshold closures or air seals will also reduce sound transmission. Sliding doors should be avoided where noise control is important. Finally, where possible, doors from suites opening onto hallways should not face one another.

Windows generally have lower sound-transmission losses than the walls that surround them. Limiting window areas will reduce unwanted noise from the outdoors. Using double-glazing and weatherstripping will also tend to improve the sound transmission loss of the window.

Figure 4.13, page 4-30, shows how a wood-frame wall assembly might be constructed to account for both fire and sound. The construction sequence clearly shows some of the important steps to help ensure predicted FRR and STC are achieved.



Adapted from, *Gypsum Board Systems Manual*, Westroc Inc.

CONSTRUCTION SEQUENCE

1. Set wood studs 600 mm (24") o.c. into wood floor and ceiling plates. Cross-brace and firestop as required.
2. Apply one layer of 15.9 mm (5/8") Type X gypsum wallboard vertically or horizontally to one side with 41 mm (1 5/8") screws spaced 300 mm (12") o.c. along edge joints and in the field; or 38 mm (1 1/2") nails spaced 200 mm (8") along edge joints and in the field.
3. Install insulation between studs.
4. Attach resilient channels horizontally at 400 mm (16") or 600 mm (24") o.c. to studs on the other side with 32 mm (1 1/4") screws. Space top channel 150 mm (6") down from top of partition, and bottom channel 400 mm (16") up from bottom of partition.
5. Apply a bead of non-hardening acoustical caulking along the bottom edge of the bottom plate.
6. Apply a 75 mm (3") wide strip of 12.7 mm (1/2") resilient fibreboard spacer along the bottom of the partition at the floor line.
7. Apply a bead of non-hardening acoustical caulking on face of resilient fibreboard spacer.
8. Apply one layer of 15.9 mm (5/8") Type X gypsum wallboard vertically to the resilient channels with 25 mm (1") screws spaced 300 mm (12"). Joints must be offset from the joints on the opposite side.
9. Apply a face layer of 15.9 mm (5/8") Type X gypsum wallboard vertically or horizontally to the resilient channel side with 41 mm (1 5/8") screws spaced 300 mm (12") o.c. Joints must be offset from joints in the underlying layer.
10. Tape and finish joints.

Figure 4.13: Gypsum board application

INTRODUCTION

This chapter continues the discussion of Chapter 4 and considers ways that floor assemblies between dwelling units control the movement of fire and sound. It provides floor assembly design and installation information and describes how performance can be improved or impaired. It discusses impact sound and flanking noise and their relationship to the design of the assembly.

In continuing the discussion begun in Chapter 4, this chapter examines the fire-resistance of floor assemblies constructed in wood, including those made with solid lumber, wood I-joists or wood trusses. The construction of floating floors is also discussed. As well, other factors in design and construction affecting the sound control and fire-resistance ratings are presented, including the impact of services. This chapter does not provide a detailed discussion of assemblies framed with steel or constructed with concrete. Because these types of floor systems are not normally part of wood-frame construction, they are beyond the scope of this *Guide*.

Fire-resistance ratings in this chapter have been determined using some of the methods already noted in Chapter 4, namely:

- Certified or listed assemblies.
- Ratings by calculation.
- Assigned ratings.
- Ratings from fire test data.

These methods are available to designers and builders for use in designing and constructing fire resistant floor assemblies.

FIRE-RESISTANCE OF SOLID WOOD JOIST CONSTRUCTION

Solid wood joist construction is a popular method for floor construction in multi-family, wood-frame buildings in Canada. Fire-resistance ratings for solid wood-joist construction may be determined by certification, calculation, assigned ratings or fire test data. Below is a discussion of each method.

With industry and CMHC involvement, NRCC completed an extensive research project on the fire-resistance of lightweight floor assemblies, including solid wood joists. Whole floor systems, not just materials, were tested to get a complete picture of performance under fire conditions. These results can provide insights for the builder and designer.²⁶

What the testing revealed was that the location of screws used to fasten gypsum board edges to resilient channels can have an influence on the fire-resistance of load bearing floor assemblies.²⁷ By placing screws away from gypsum board edges (38 mm (1-1/2 in.) as opposed to the current practice of 10–12 mm (1/2 in.)) the fire-resistance increased by about 50 per cent. In practice the NRCC suggests:

Fire Resistance of Floor Assemblies

- Decreasing the number of fasteners which hold the layers of gypsum board in place may reduce the fire resistance of the assembly.
- The type of subfloor (OSB or plywood) has no effect on the fire resistance of floor assemblies.
- Widening the spacing of resilient channels can decrease a floor assembly's fire resistance rating.

Reference:

Sultan, M.A., "Fire Resistance of Floor Assemblies in Multi-Family Dwellings", NRC, IRC Construction Technology Update No. 20, 1998.

²⁶ Sultan, M.A., Seguin, Y.P., Leroux, P., "Results of Fire Resistance Tests on Full-Scale Floor Assemblies," IRC Internal Report No. 764, National Research Council of Canada, Ottawa, ON, 1998.

²⁷ Sultan, M.A., "Fire Resistance of Floor Assemblies in Multi-Family Dwellings," Construction Technology Update 20, Institute for Research in Construction, National Research Council of Canada, September 1998.

For floor assemblies with two sheets of gypsum board (base layer and face layer), the fire-resistance of the face layer is more critical for overall performance than that of the base layer. The base layer can be fastened to the resilient channels with screws at 10 mm (1/2 in.) from the board edges. The face layer can be fastened to the base layer and resilient channels in three different ways using:

1. Type G screws (commonly used to attach butt ends of two layers of gypsum board to each other) at 38 mm (1-1/2 in.) from the edges of the board, in which case, double rows of regular-size resilient channels are not required.
2. Regular drywall screws at 38 mm (1-1/2 in.) from the edges with double resilient channels.
3. Regular drywall screws at 38 mm (1-1/2 in.) from the edges with resilient channels with a wider flange.

Using two layers of gypsum board ceiling finish, instead of one, significantly improves the fire-resistance rating of the floor assembly. A second layer can increase the fire-resistance rating by 78 per cent for solid wood joists. The fire-resistance rating also improved when Type G screws were used on gypsum board face layer butt ends in two-layer assemblies, when compared to floating butt ends.

Insulation can reduce the heat transmission away from the gypsum board ceiling membrane, causing it to dry and crack faster than in an assembly with no insulation. In fact, test results show that glass fibre batt insulation installed in solid wood joist assemblies with a single layer of gypsum board attached to resilient channels reduced the fire-resistance by about 20 per cent compared to the same assembly without insulation. Rock fibre batt and cellulose insulation, on the other hand, tended to stay in place longer after the gypsum board fell off and increased the fire-resistance rating of the assembly by more than 30 per cent. In assemblies with a double layer of gypsum board, glass fibre, rock fibre and cellulose reduced the fire-resistance from between 7.5 per cent and 16 per cent. Increasing the spacing between resilient channels from 400 mm (16 in.) to 600 mm (24 in.) o.c. for floor assemblies with gypsum board ceiling finish decreases the fire-resistance rating. The wider spacing can decrease the number of fasteners that hold the gypsum board and thus decrease the chances of it staying in place and protecting the frame. There are no differences between OSB and plywood subfloors that affect fire-resistance rating. The NRCC test results showed that the fire-resistance rating of a floor assembly that includes a concrete topping decreased by 12 per cent when compared to a floor without the topping. The topping increased the thermal resistance of the assembly and caused the gypsum board to dry, crack and fall off sooner than in an assembly with no topping. In fact, the topping caused the entire assembly to heat up and degrade faster than otherwise.

CERTIFIED OR LISTED ASSEMBLIES

There are numerous solid wood joist floor assemblies included in the listing books of Canadian certification agencies. These provide a number of ways to meet fire-resistance requirements using a variety of gypsum boards and other proprietary ceiling materials (for example, ceiling tiles). Like walls, modifications to a specified design are only possible where an assessment by the certification agency to determine the impact of the changes is provided.

RATINGS BY CALCULATION

Computer-based mathematical modelling techniques for calculating the fire endurance of solid wood joist construction are in the very early stages of development. Calculating fire impact in combination with full structural load is presenting a challenge to modellers, basically eliminating this method as an alternative for designers and builders at this time. References are available to assist the designer in understanding the relevant issues.^{28, 29, 30}

As discussed in Chapter 4 for wall assemblies, “Appendix D” of the NBCC provides a calculation technique called the “component additive method” to determine the fire-resistance of some solid wood joist floor assemblies. It describes a methodology that consists of adding the contributions to fire-resistance of each of the components of the floor assembly. Individual contributions were derived from a review of a number of fire tests conducted over a period of over 50 years. The method, as applied to floor assemblies, is detailed below:

Fire-exposed membrane—The calculation method begins by considering the membrane on the fire-exposed (ceiling) side of the assembly. The ratings assigned to 12.7 and 15.9 mm Type X gypsum board are based on the capability of the membrane to remain in place during the fire test. NBCC “Appendix D” also contains information on plaster membranes installed on the fire-exposed side.

Floor frame—The second step in the calculation is to consider the contribution of the framing members. Table 5.2, page 5-4, contains the contributions for the floor-framing members of wood joists and wood trusses. The time assigned to the frame represents the time the framing members are able to continue to carry the load, after the ceiling membrane falls off.

Insulation—Unlike the component additive method for walls, the calculation method does not assign any contribution for the inclusion of insulation installed above the ceiling in the joist cavity. The installation of insulation in the cavity of a floor assembly assigned a fire-resistance rating must be done in accordance with specific details described in “Appendix D” of the NBCC. This is required so that the presence of insulation does not degrade the assigned fire-resistance of the assembly.

Non-fire-exposed membrane (floor or subfloor)—No contribution is included for the non-fire-exposed membrane (floor or subfloor) since it is assumed that it will fail at the same time as the framing members fail.

Add the contributions from fire exposed membrane and the floor frame to determine the overall fire-resistance rating of the assembly.

²⁸ King, E.G. and Glowinski R.W., “A Rationalized Model for Calculating the Fire Endurance of Wood Beams,” 1988.

²⁹ Lau, P.W.C., White, R., and Zealand, I.V., “Modelling the Charring Behavior of Structural Lumber,” 1998.

³⁰ Lau, P.W., and Barrett, J.D., “Modelling Tension Strength Behavior of Structural Lumber Exposed to Elevated Temperatures,” 1996.

Table 5.1: Time assigned to membranes on fire-exposed side (from NBCC, 1995)

Description of finish	Time in minutes
12.7 mm (1/2 in.) Type X gypsum wallboard	25
15.9 mm (5/8 in.) Type X gypsum wallboard	40

Table 5.2: Time assigned for contribution of floor frame

Description of frame	Assigned to frame in minutes
Wood floor joists spaced 400 mm (16 in.) o.c. maximum	10
Wood floor truss assemblies 600 mm (24 in.) o.c. maximum	5

A number of limitations must be noted when using the component additive method, namely:

- No additional credit is given for multiple layers of gypsum board.
- Maximum rating achievable using this method is 50 minutes.
- Solid wood joists are assumed to be properly sized to support superimposed loads across specified spans and not to exceed the maximum permitted in Part 9 of the NBCC.
- Gypsum board edges must be supported.
- Membranes are fastened as detailed in Figure 4.2, page 4-11, and Table 5.3, page 5-5, (both in terms of spacing of fasteners and depth of penetration).
- Subfloor and finish flooring must conform to Table 5.4, page 5-5.

While this method of calculation is somewhat simplistic, it provides designers and builders with another means to determine fire-resistance of generic assemblies.

The component additive method was completely revised in the 1995 NBCC from its original form, developed in the 1960s. Consequently, the variety of floor assemblies than can be assigned fire-resistance ratings using this technique is now quite limited. However, between 1994 and 1998 significant research work was undertaken at NRCC to look at a variety of wood joist and wood I-joist floor assemblies to determine whether or not the assigned fire-resistance rating values were still valid. The assigned fire-resistance ratings listed for the assemblies described in Figure 5.1, page 5-9, verified that the generic ratings originally developed using the component additive method are still valid.

Table 5.3: Minimum fastener penetrations for membrane protection on wood-frame, mm (in.) (From NBCC, 1995)

Type of membrane	Assigned contribution of membrane to fire-resistance, in minutes*†				
	5–25	30–35	40	50	55–70
Single layer	20 (3/4)	29 (1-3/16)	32 (1-5/16)	—	—
Double layer	20 (3/4)	20 (3/4)	20 (3/4)	29 (1-3/16)	35 (1-3/8)

* For membranes attached to resilient or metal furring channels refer to CSA Standard A82.31.
† Table 5.1, page 5-4, lists assigned contributions of membranes to fire-resistance.

Table 5.4: Flooring membranes (From Table D-2.3.5, NBCC, 1995)

Type of assembly	Structural members	Subfloor or roof deck	Finish flooring or roofing
Floor	Wood joists or trusses	12.5 mm (1/2 in.) plywood or 17 mm (5/8 in.) T&G softwood	Hardwood or softwood flooring on building paper. Resilient flooring, parquet floor, felted synthetic fibre floor coverings, carpeting, or ceramic tile on 8 mm (3/8 in.) thick panel-type underlay. Ceramic tile on 30 mm (1-3/16 in.) mortar bed.

ASSIGNED RATINGS

The NBCC contains assigned ratings for a limited number of solid wood joist floor assemblies. It also provides ratings for floor assemblies or trusses made with different gypsum boards, insulations and floor materials, including resilient metal channels. As well, it includes information on concrete toppings for floor decks. The ratings assigned in the NBCC are permitted to be used for multi-family wood-frame buildings with Part 9 and are reproduced in Figure 5.1, page 5-9.

Like the information in Chapter 4 on wood-stud wall assemblies, recently, the technical committees that develops the NBCC has updated the listings in “Appendix A” of the Code for fire-resistance ratings of wood-frame floor assemblies.

A greater variety of descriptions of floor assemblies than that published in earlier versions of the NBCC is now included. The information listed provides guidance on the effects of various details of construction that can influence the assigned fire-resistance ratings. These include:

- Use of wood furring instead of metal furring or resilient metal channels.
- Use of insulation and the type of insulation used.
- Type, thickness and number of layers of gypsum wallboard used.
- Type and thickness of various floor toppings including double wood panel subfloors, gypsum concrete topping and lightweight concrete topping.

Generic ratings for the wood joist floor assemblies range from less than 30 minutes up to one hour, depending on their configuration. Refer to Figure 5.1, page 5-9, for details of the different assemblies and their assigned ratings.

All the listings apply to floor assemblies with wood joists designed to carry loads that would stress them to 100 per cent of their bending capacity. The research data used to develop this new information showed that reducing the structural load and thereby reducing the stress on the wood joists can sometimes increase the assigned fire-resistance of the assembly from 45 minutes to one hour.

This increase in fire-resistance with reduced loads is similar to what is seen with some wood-stud wall systems, where the assigned fire-resistance rating for a load-bearing wall can change from 45 minutes to one hour or from 1-1/2 hours to two hours, when the wall is non-load-bearing. See Figure 4.1, page 4-3.

The ratings assigned in Figure 5.1, page 5-9, are permitted to be used for multi-family wood-frame buildings and any other building constructed in accordance with the requirements of Part 9 of the NBCC. Although not explicitly stated in the NBCC, the values listed in the Figure are based on the results of standard fire-resistance test procedures referenced in Article 3.1.7.1 in Part 3 of the NBCC and on that basis, can also be used for all buildings, including multi-family wood-frame buildings, constructed in accordance with Parts 3 and 4 of the NBCC.

Some of the values listed are based on extrapolation of information from tests of similar assemblies. However, where there was not adequate information available to confidently assign a rating, the Table was left blank (hyphen) until adequate information becomes available. Recent research initiatives at NRCC will be investigating many of these cases.

The NBCC also contains information and assigned ratings for ceiling membranes only, independent of the structural framing system. In these cases the times assigned to the ceiling membranes differ from those assigned in the component additive method. Also, it includes information for 1 h. fire-resistance ratings from using double gypsum board layers. Table 5.5, page 5-7, lists these values for ceiling membrane ratings. These ceiling membrane ratings can be used only when the floor assembly uses solid wood joists spaced up to 400 mm o.c. or metal plate-connected wood trusses spaced up to 600 mm o.c. The use of this approach for floors using other structural components such as wood I-joists and metal-webbed wood trusses is currently not recognized by the NBCC.

FIRE-RESISTANCE OF WOOD I-JOIST CONSTRUCTION

Wood I-joists are an efficient means of providing structural support in wood-frame construction and constitute close to 30 per cent of the current market for floor assemblies in single-family dwellings. Information on the fire-resistance of these assemblies is increasing as their use increases in multi-family and commercial construction.

Fire-resistance ratings for wood I-joist assemblies can be determined by certification, by using fire test data or by using information recently approved for the NBCC on assigned generic fire-resistance ratings. There is currently little or no information for calculating the fire-resistance of these assemblies using computer-based fire models.

The NRCC joint research project described earlier also tested the fire-resistance of a number of assemblies that use wood I-joists. As noted above, these results can provide additional insights on floor performance.

Table 5.5: Fire-resistance rating for ceiling membranes
(from Table D-2.3.12, NBCC, 1995)

Description of membrane	Fire-resistance rating in minutes
15.9 mm Type X gypsum wallboard with 75 mm mineral wool batt insulation above wallboard	30
19 mm gypsum-sand plaster on metal lath	30
Double 14 mm Douglas Fir plywood phenolic bonded	30
Double 12.7 mm Type X gypsum wallboard	45
25 mm gypsum-sand plaster on metal lath	45
Double 15.9 mm Type X gypsum wallboard	60
32 mm gypsum-sand plaster on metal lath	60

The effects of variables such as floor loading, resilient channel spacing and subfloor thickness were investigated as part of the testing program. The fire-resistance tests revealed the following:

- The effects of gypsum board screw spacing from board edges, insulation and additional drywall layers in wood I-joists are similar to those of solid wood joists.
- Wood I-joist flange configuration and size affected the fire-resistance of the floor assembly.
- Increasing the spacing of the wood I-joists, in assemblies with resilient channels, increased the fire-resistance of the assembly since the larger cavity increases convective cooling reducing the heat build up in the gypsum board core.
- Increasing the spacing of the resilient channels themselves reduces the number of screws holding the gypsum board in place and reduces the likelihood it will stay in place under fire conditions, reducing fire-resistance.

CERTIFIED OR LISTED ASSEMBLIES

Manufacturers of wood I-joists have obtained ratings for numerous assemblies, as listed by the certification agencies. Up until the adoption of the recent changes to the NBCC, these had provided the commonest way today of using wood I-joists where fire-resistant construction is required. Modifications to specific designs can be accomplished only by additional studies by the certifying agency. Several documents are available that provide guidance on the extrapolation of data from results of fire-resistance tests on proprietary assemblies.^{31, 32}

These provide the most current method today of using wood I-joists where fire-resistant construction is required. Modifications to specific designs can be accomplished only by additional studies by the certifying agency.

³¹ “ULC Subject C263(e) M1988—Criteria for Use in Extension of Data from Fire Endurance Tests,” Underwriters Laboratories of Canada.

³² “ASTM E 2032-99—Standard Guide for Extension of Data from Fire Endurance Tests,” American Society of Testing and Materials.

FIRE-RESISTANCE OF WOOD-TRUSS CONSTRUCTION

Wood trusses, like wood I-joists, are also an efficient means of providing structural support in wood-frame construction. There is little information on the fire-resistance of wood-truss floor assemblies but like wood joists, fire-resistance ratings for wood-truss assemblies can be determined by certification, calculation or by using assigned values.

Work is currently underway at NRCC to update and expand on the assigned ratings for wood truss floor assemblies, similar to what was recently done for wood joists and wood I-joists. There is currently little or no information for calculating the fire-resistance of wood-truss assemblies by using computer-based fire models.

CERTIFIED OR LISTED ASSEMBLIES

There are a number of assemblies using wood trusses listed by the certification agencies, most of which use metal truss plates to connect the truss members to each other. Some truss configurations that are listed use metal or tubular webs. Listings are commonly used where wood trusses are installed in fire-resistant construction. Interchangeability between designs is usually possible with a study by the certification agency. Several documents are available that provide guidance on the extrapolation of data from results of fire-resistance tests on proprietary assemblies.^{33, 34}

RATINGS BY CALCULATION

Like the other wood floor assemblies, there is limited information available to allow the calculation of fire-resistance of wood-truss floor assemblies using computer fire-modelling. Designers or builders wanting to calculate the fire-resistance must use the information included in “Appendix D” of the NBCC. The component additive method does apply to metal-plate connected wood trusses when all the truss members use lumber that is a minimum of 38 by 89 mm (2 in. x 4 in.) in size, the metal plates are a minimum 1 mm in thickness and the plate teeth are not less than 8 mm in length. There is no information currently available supporting the use of smaller dimension lumber as the wood members in the trusses.

The component additive method for wood-truss assemblies, including both the ceiling membrane rating as well as the floor assembly rating, is identical to that for solid wood joist assemblies. Refer to that section for details.

ASSIGNED RATINGS

The NBCC has assigned ratings to a number of wood-truss floor assemblies. These are shown in Figure 5.1, page 5-9.

³³ “ULC Subject C263(e) M1988—Criteria for Use in Extension of Data from Fire Endurance Tests,” Underwriters Laboratories of Canada.

³⁴ “ASTM E 2032-99, Standard Guide for Extension of Data from Fire Endurance Tests,” American Society of Testing and Materials.





Assembly	Assembly Number	Description	Fire Resistance Rating	Sound Transmission Class
	F4	<ul style="list-style-type: none"> •One subfloor layer of 11 mm sanded plywood, OSB or waferboard; one subfloor layer of 19 mm tongue and groove lumber or 15.5 mm plywood, OSB or waferboard •On wood joists spaced not more than 400 mm o.c., or on wood trusses spaced not more than 600 mm o.c. •Absorptive material in cavity •Resilient metal channels spaced at 200 mm o.c. •One layer of gypsum board on ceiling side 		
	F4a	F4 with: <ul style="list-style-type: none"> •15.9 mm Type X gypsum board 	45 min	50
	F5	<ul style="list-style-type: none"> •Gypsum-concrete or lightweight concrete topping •Subfloor of 19 mm tongue and groove lumber or 15.5 mm plywood, OSB or waferboard, on wood joists spaced not more than 400 mm o.c., or on wood trusses spaced not more than 600 mm o.c. •Two layers of gypsum board on ceiling side 		
	F5a	F5 with: <ul style="list-style-type: none"> •19 mm gypsum-concrete or lightweight concrete topping (at least 34 kg/m²) •15.9 mm Type X gypsum board 	1 h	52
	F5b	F5 with: <ul style="list-style-type: none"> •19 mm gypsum-concrete or lightweight concrete topping (at least 34 kg/m²) •12.7 mm Type X gypsum board 	45 min	50
	F5c	F5 with: <ul style="list-style-type: none"> •38 mm lightweight concrete topping (at least 70 kg/m²) •15.9 mm Type X gypsum board 	1 h	54
	F5d	F5 with: <ul style="list-style-type: none"> •38 mm lightweight concrete topping (at least 70 kg/m²) •12.7 mm Type X gypsum board 	45 min	52
  Denotes Best Practice	F6	<ul style="list-style-type: none"> •Gypsum-concrete or lightweight concrete topping •Subfloor of 19 mm tongue and groove lumber or 15.5 mm plywood, OSB or waferboard; on wood joists spaced not more than 400 mm o.c., or on wood trusses spaced not more than 600 mm o.c. •With or without absorptive material in cavity •Resilient metal channels spaced at 200 mm o.c. •One layer of gypsum board 		
	 F6a	F6 with: <ul style="list-style-type: none"> •19 mm gypsum-concrete or lightweight concrete topping (at least 34 kg/m²) •Absorptive material in cavity •15.9 mm Type X gypsum board 	45 min	55
	 F6b	F6 with: <ul style="list-style-type: none"> •38 mm lightweight concrete topping (at least 70 kg/m²) •Absorptive material in cavity •15.9 mm Type X gypsum board 	45 min	60
	 F6c	F6 with: <ul style="list-style-type: none"> •38 mm lightweight concrete topping (at least 70 kg/m²) •No absorptive material in cavity 	45 min	57

Figure 5.1: Ratings for floor assemblies

UNRATED FLOOR ASSEMBLIES

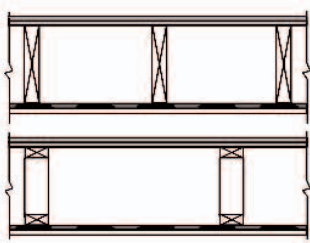
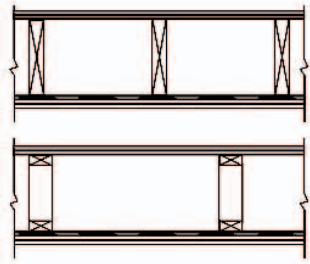
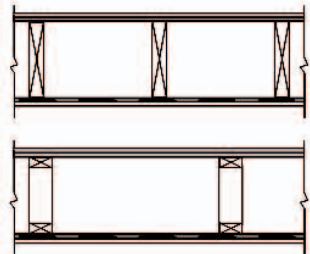
Any floor assembly that separates individual dwelling units is required to provide a minimum STC of 50 and be constructed as a fire separation with a minimum fire-resistance of either 45 minutes or one hour.

Where a fire-resistance rating is required for a floor assembly, the minimum rating 45 minutes or one hour is governed by the size of the building and the arrangement of the units in the building. Table 3.1, page 3-7, contains information on building size that must be used to determine the minimum fire ratings required for floor assemblies in the building.

The arrangements of the dwelling units in the building also affects the minimum fire-resistance rating required for floors. In buildings where multi-storey dwelling units are stacked above one another, the floor assemblies between the units must be built as fire separations having a 1 h. fire-resistance rating, regardless of the building area or height. The floor assemblies within individual stacked units must also have a fire-resistance rating, but need not be constructed as fire separations. See Figure 5.2, page 5-11.

In buildings where single-storey dwelling units are stacked above one another, the fire-resistance rating of floor assemblies between the units must be either 45 minutes or one hour, depending on the building size. In buildings with multi-storey units where no units are built over one another, the floor assemblies within dwelling units, such as floors over basements and second floors are not required to be constructed as fire separations nor have a fire-resistance rating or meet any minimum acoustical performance level.

Type of Assembly	Assembly Number	Description ⁽⁹⁾⁽¹⁰⁾	Fire Resistance Rating ⁽¹⁾⁽³⁾	Typical Sound Transmission Class (STC) ⁽¹⁾⁽²⁾⁽³⁾⁽⁷⁾	Typical Impact Insulation Class (IIC) ⁽¹⁾⁽²⁾⁽¹¹⁾
Wood Floor Joists (Wood joists minimum 38 x 235 mm, Wood I-Joists minimum 38 x 38 flange 9.5 mm OSB or plywood web, minimum 241 mm deep)	F9	<ul style="list-style-type: none"> subfloor of 15.5 mm plywood, OSB or waferboard or 17.5 mm tongue and groove lumber on wood joists spaced not more than 600 mm o.c. with or without absorptive material in cavity resilient metal channels spaced 400 mm or 600 mm o.c. 2 layers of gypsum board on ceiling side (wood joists or wood I-joists) (gypsum board on R/C) 			
	F9c	F9 with <ul style="list-style-type: none"> absorptive material in cavity resilient metal channels spaced 400 mm o.c. 15.9 mm Type X gypsum board 	1h	54	47
	F9d	F9 with <ul style="list-style-type: none"> absorptive material in cavity resilient metal channels spaced 600 mm o.c. 15.9 mm Type X gypsum board 	1h	55	49
	F9g	F9 with <ul style="list-style-type: none"> absorptive material in cavity resilient metal channels spaced 400 mm o.c. 12.7 mm Type X gypsum board 	1h	54	47
	F9h	F9 with <ul style="list-style-type: none"> absorptive material in cavity resilient metal channels spaced 600 mm o.c. 12.7 mm Type X gypsum board 	1h	55	49
	F10	<ul style="list-style-type: none"> one subfloor layer of 11 mm sanded plywood, or OSB or waferboard one subfloor layer of 15.5 mm plywood, OSB or waferboard or 17 mm tongue and groove lumber on wood joists spaced not more than 600 mm o.c. with or without absorptive material in cavity resilient metal channels spaced 400 or 600 mm o.c. 1 layer of gypsum board on ceiling side (two layers of subfloor) (wood joists or wood I-joists) (gypsum board on R/C) 			
	F10c	F10 with <ul style="list-style-type: none"> absorptive material in cavity resilient metal channels spaced 400 mm o.c. 15.9 mm Type X gypsum board 	<45 min [45 min] ⁽⁹⁾⁽¹²⁾	50	43
	F11	<ul style="list-style-type: none"> one subfloor layer of 11 mm sanded plywood, or OSB or waferboard one subfloor layer of 15.5 mm plywood, OSB or waferboard or 17 mm tongue and groove lumber on wood joists spaced not more than 600 mm o.c. with or without absorptive material in cavity resilient metal channels spaced 400 or 600 mm o.c. 2 layers of gypsum board on ceiling side (two layers of subfloor) (wood joists or wood I-joists) (gypsum board on R/C) 			
	F11a	F11 with <ul style="list-style-type: none"> no absorptive material in cavity resilient metal channels spaced 400 mm o.c. 15.9 mm Type X gypsum board 	1h	50	41
	F11b	F11 with <ul style="list-style-type: none"> no absorptive material in cavity resilient metal channels spaced 600 mm o.c. 15.9 mm Type X gypsum board 	1h	51	42
	F11c	F11 with <ul style="list-style-type: none"> absorptive material in cavity resilient metal channels spaced 400 mm o.c. 15.9 mm Type X gypsum board 	1h	57	50
	F11d	F11 with <ul style="list-style-type: none"> absorptive material in cavity resilient metal channels spaced 600 mm o.c. 15.9 mm Type X gypsum board 	1h	58	51

Figure 5.2: Fire-resistance ratings for floors in multi-storey, stacked dwelling units

Type of Assembly	Assembly Number	Description ⁽⁴⁾⁽⁶⁾⁽⁸⁾	Fire Resistance Rating ⁽¹⁾⁽⁹⁾	Typical Sound Transmission Class (STC) ⁽¹⁾⁽²⁾⁽³⁾⁽⁷⁾	Typical Impact Insulation Class (IIC) ⁽¹⁾⁽²⁾⁽¹¹⁾
Wood Floor Joists (Wood joists minimum 38 x 235 mm, Wood I-Joists minimum 38 x 38 flange 9.5 mm OSB or plywood web, minimum 241 mm deep)	F11e	F11 with <ul style="list-style-type: none"> no absorptive material in cavity resilient metal channels spaced 400 mm o.c. 12.7 mm Type X gypsum board 	1h	50	41
	F11f	F11 with <ul style="list-style-type: none"> no absorptive material in cavity resilient metal channels spaced 600 mm o.c. 12.7 mm Type X gypsum board 	1h	51	42
	F11g	F11 with <ul style="list-style-type: none"> absorptive material in cavity resilient metal channels spaced 400 mm o.c. 12.7 mm Type X gypsum board 	1h	57	50
	F11h	F11 with <ul style="list-style-type: none"> absorptive material in cavity resilient metal channels spaced 600 mm o.c. 12.7 mm Type X gypsum board 	1h	58	51
	F14	<ul style="list-style-type: none"> 25 mm gypsum-concrete topping (at least 44 kg/m²) subfloor of 15.5 mm plywood, OSB or waferboard or 17 mm tongue and groove lumber on wood joists spaced not more than 600 mm o.c. with or without absorptive material in cavity resilient metal channels spaced 400 mm or 600 mm o.c. 1 layer of gypsum board (gypsum-concrete topping) (wood joists or wood I-joists) (gypsum board on R/C) 			
	F14c	F14 with <ul style="list-style-type: none"> absorptive material in cavity resilient metal channels spaced 400 mm o.c. 15.9 mm Type X gypsum board 	<45 min [45 min] ⁽⁹⁾⁽¹²⁾	57	24
	F15	<ul style="list-style-type: none"> 25 mm gypsum-concrete topping (at least 44 kg/m²) subfloor of 15.5 mm plywood, OSB or waferboard or 17 mm tongue and groove lumber on wood joists spaced not more than 600 mm o.c. with or without absorptive material in cavity resilient metal channels spaced 400 mm or 600 mm o.c. 2 layers of gypsum board on ceiling side (gypsum-concrete topping) (wood joists or wood I-joists) (gypsum board on R/C) 			
	F15a	F15 with <ul style="list-style-type: none"> no absorptive material in cavity resilient metal channels spaced 400 mm o.c. 15.9 mm Type X gypsum board 	1h ⁽¹²⁾	55	26
	F15e	F15 with <ul style="list-style-type: none"> no absorptive material in cavity resilient metal channels spaced 400 mm o.c. 12.7 mm Type X gypsum board 	1h ⁽¹²⁾	55	26
	F19	<ul style="list-style-type: none"> 38 mm concrete topping (at least 70 kg/m²) subfloor of 15.5 mm plywood, OSB or waferboard or 17 mm tongue and groove lumber on wood joists spaced not more than 600 mm o.c. with or without absorptive material in cavity metal furring channels spaced 400 mm or 600 mm o.c. 2 layers of gypsum board on ceiling side (concrete topping) (wood joists or wood I-joists) (gypsum board on furring) 			
F19a	F19 with <ul style="list-style-type: none"> no absorptive material in cavity metal furring channels spaced 400 mm o.c. 15.9 mm Type X gypsum board 	1h	52	31	
F19e	F19 with <ul style="list-style-type: none"> no absorptive material in cavity metal furring channels spaced 400 mm o.c. 12.7 mm Type X gypsum board 	1h	52	31	

Figure 5.2: Fire-resistance ratings for floors in multi-storey, stacked dwelling units

Type of Assembly	Assembly Number	Description ⁽⁴⁾⁽⁵⁾⁽⁶⁾	Fire Resistance Rating ⁽¹⁾⁽²⁾	Typical Sound Transmission Class (STC) ⁽¹⁾⁽²⁾⁽³⁾⁽⁷⁾	Typical Impact Insulation Class (IIC) ⁽¹⁾⁽²⁾⁽¹¹⁾
Wood Floor Joists (Wood joists minimum 38 x 235 mm, Wood I-Joists minimum 38 x 38 flange 9.5 mm OSB or plywood web, minimum 241 mm deep)	F20	<ul style="list-style-type: none"> • 38 mm concrete topping (at least 70 kg/m²) • subfloor of 15.5 mm plywood, OSB or waferboard or 17 mm tongue and groove lumber • on wood joists spaced not more than 600 mm o.c. • with or without absorptive material in cavity • resilient metal channels spaced 400 mm or 600 mm o.c. • 1 layer of gypsum board (concrete topping) • (wood joists or wood I-joists) • (gypsum board on R/C) 			
	F20a	F20 with <ul style="list-style-type: none"> • no absorptive material in cavity • resilient metal channels spaced 400 mm o.c. • 15.9 mm Type X gypsum board 	45 min ⁽¹²⁾	57	28
	F20c	F20 with <ul style="list-style-type: none"> • absorptive material in cavity • resilient metal channels spaced 400 mm o.c. • 15.9 mm Type X gypsum board 	<45 min [45 min] ⁽⁹⁾⁽¹²⁾	64	35
	F21	<ul style="list-style-type: none"> • 38 mm concrete topping (at least 70 kg/m²) • subfloor of 15.5 mm plywood, OSB or waferboard or 17 mm tongue and groove lumber • on wood joists spaced not more than 600 mm o.c. • with or without absorptive material in cavity • resilient metal channels spaced 400 mm or 600 mm o.c. • 2 layers of gypsum board on ceiling (concrete topping) • (wood joists or wood I-joists) • (gypsum board on R/C) 			
	F21a	F21 with <ul style="list-style-type: none"> • no absorptive material in cavity • resilient metal channels spaced 400 mm o.c. • 15.9 mm Type X gypsum board 	1h	64	36
	F21e	F21 with <ul style="list-style-type: none"> • no absorptive material in cavity • resilient metal channels spaced 400 mm o.c. • 12.7 mm Type X gypsum board 	1h	64	36
Wood Floor Trusses (wood framing members not less than 38 mm x 89 mm with metal connector plates not less than 1 mm thick with teeth not less than 8 mm in length - minimum 235 mm depth)	F29	<ul style="list-style-type: none"> • subfloor layer 11 mm sanded plywood, or OSB or waferboard • one subfloor layer of 15.5 mm plywood, OSB or waferboard or 17 mm tongue and groove lumber • on wood trusses spaced not more than 600 mm o.c. • with or without absorptive material in cavity • resilient metal channels spaced 400 mm or 600 mm o.c. • 1 layer of gypsum board on ceiling side • (two layers of subfloor) • (wood trusses) • (gypsum board on R/C) 			
	F29c	F29 with <ul style="list-style-type: none"> • absorptive material in cavity • resilient metal channels spaced 400 mm o.c. • 15.9 mm Type X gypsum board 	<45 min [45 min] ⁽¹⁰⁾	50	43
	F33	<ul style="list-style-type: none"> • 25 mm gypsum-concrete topping (at least 44 kg/m²) • subfloor of 15.5 mm plywood, OSB or waferboard or 17 mm tongue and groove lumber • on wood trusses spaced not more than 600 mm o.c. • with or without absorptive material in cavity • resilient metal channels spaced 400 mm or 600 mm o.c. • 1 layer of gypsum board (gypsum-concrete topping) • (wood trusses) • (gypsum board on R/C) 			
	F33c	F33 with <ul style="list-style-type: none"> • absorptive material in cavity • resilient metal channels spaced 400 mm o.c. • 15.9 mm Type X gypsum board 	<45 min [45 min] ⁽¹⁰⁾	57	24

Figure 5.2: Fire-resistance ratings for floors in multi-storey, stacked dwelling units

Type of Assembly	Assembly Number	Description ⁽⁴⁾⁽⁵⁾⁽⁹⁾	Fire Resistance Rating ⁽¹⁾⁽³⁾	Typical Sound Transmission Class (STC) ⁽¹⁾⁽²⁾⁽³⁾⁽⁷⁾	Typical Impact Insulation Class (IIC) ⁽¹⁾⁽²⁾⁽¹¹⁾
Wood Floor Trusses (wood framing members not less than 38 mm x 89 mm with metal connector plates not less than 1 mm thick with teeth not less than 8 mm in length - minimum 235 mm depth)	F34	<ul style="list-style-type: none"> 25 mm gypsum-concrete topping (at least 44 kg/m²) subfloor of 15.5 mm plywood, OSB or waferboard or 17 mm tongue and groove lumber on wood trusses spaced not more than 600 mm o.c. with or without absorptive material in cavity resilient metal channels spaced 400 mm or 600 mm o.c. 2 layers of gypsum board on ceiling side (gypsum-concrete topping) (wood trusses) (gypsum board on R/C) 			
	F34a	F34 with <ul style="list-style-type: none"> no absorptive material in cavity resilient metal channels spaced 400 mm o.c. 15.9 mm Type X gypsum board 	1h	55	26
	F34e	F34 with <ul style="list-style-type: none"> no absorptive material in cavity resilient metal channels spaced 400 mm o.c. 12.7 mm Type X gypsum board 	45 min	55	26
	F37	<ul style="list-style-type: none"> 38 mm gypsum-concrete topping (at least 70 kg/m²) subfloor of 15.5 mm plywood, OSB or waferboard or 17 mm tongue and groove lumber on wood trusses spaced not more than 600 mm o.c. with or without absorptive material in cavity resilient metal channels spaced 400 mm or 600 mm o.c. 1 layer of gypsum board (concrete topping) (wood trusses) (gypsum board on R/C) 			
	F37a	F37 with <ul style="list-style-type: none"> no absorptive material in cavity resilient metal channels spaced 400 mm o.c. 15.9 mm Type X gypsum board 	45 min	57	28
	F37c	F37 with <ul style="list-style-type: none"> absorptive material in cavity resilient metal channels spaced 400 mm o.c. 15.9 mm Type X gypsum board 	<45 min [45 min] ⁽¹⁰⁾	64	35
	F38	<ul style="list-style-type: none"> 38 mm gypsum-concrete topping (at least 70 kg/m²) subfloor of 15.5 mm plywood, OSB or waferboard or 17 mm tongue and groove lumber on wood trusses spaced not more than 600 mm o.c. with or without absorptive material in cavity resilient metal channels spaced 400 mm or 600 mm o.c. 2 layers of gypsum board on ceiling side (concrete topping) (wood trusses) (gypsum board on R/C) 			
	F38a	F38 with <ul style="list-style-type: none"> no absorptive material in cavity resilient metal channels spaced 400 mm o.c. 15.9 mm Type X gypsum board 	1h	64	36

Figure 5.2: Fire-resistance ratings for floors in multi-storey, stacked dwelling units

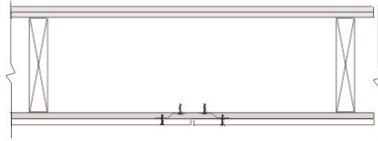

Figure A - Single Layer Butt Joint Details

Notes:

1. Figure is for illustration purposes only and is not to scale.
2. The structural member can be any one of the types described in the Table.
3. Adjacent gypsum board butt ends are to be attached to separate resilient channels using regular Type S screws, located a minimum of 38 mm from the butt end.



Figure B - Double Layer Butt Joint Details

Notes:

1. Figure is for illustration purposes only and is not to scale.
2. The structural member can be any one of the types described in the Table.
3. Base layer butt ends can be attached to a single resilient channel using regular Type S screws.
4. Type G screws, located a minimum of 38 mm from the butt end and a minimum 32 mm in length, are to be used to fasten the butt ends of the face layer to base layer.

Notes:

- 1) Sound absorptive material includes fibre processed from rock, slag, glass or cellulose fibre either loose-fill or spray applied. To obtain the listed STC rating, the nominal insulation thickness is 150 mm for rock, slag, glass or loose fill cellulose fibre and 90 mm for spray applied cellulose fibre. Absorptive material will affect the STC by approximately 1 dB per 50 mm change of thickness.
- 2) STC values given are for depth of framing member noted. For shallower members reduce the STC by 1 for each 50 mm reduction in framing depth. For framing members deeper than noted add 1 STC for each 50 mm increase in framing depth.
- 3) The fire and sound ratings are based on the spacing of ceiling supports as noted. A narrower spacing will be detrimental to the sound rating but not for the fire rating.
- 4) For systems with a ceiling of a single layer of gypsum board on resilient channels, the resilient channel arrangement at the gypsum board butt ends is to be shown as in Figure A.
- 5) For systems with a ceiling of 2 layers of gypsum board and resilient channels, the fastener and resilient channel arrangement at the gypsum board butt end joints are to be shown as in Figure B.
- 6) STC values given are for minimum thickness of subfloor as shown. Minimum subfloor thickness required is determined by joist or truss spacing - see Table 9.23.14.5.A. Thicker subflooring is also acceptable.
- 7) STC values given reflect results for joist spacing of not less than 400 mm o.c. unless otherwise specified. For joist spacing of at least 600 mm o.c., add 2 STC to the values given in the Table.
- 8) Except as noted below, type and spacing of fasteners shall be in accordance with subsection 9.29.5 or CAN/CSA-A82.31:
 - i) except for fasteners on the butt ends of the base layer in ceilings with two layers (See Figure B), fastener distance to board edges and butt ends shall not be less than 38 mm
 - ii) fastener spacing shall not exceed 300 mm.
- 9) The 45 min fire rating applies if absorptive material includes:
 - i) mineral fibre processed from rock or slag with a thickness of 90 mm and 2.8 kg/m² or,
 - ii) cellulose fibre spray applied with a minimum depth of 90 mm on the underside of the deck and 90 mm on the sides of the floor joists and a minimum density of 50 kg/m³.
- 10) The 45 min fire rating applies if absorptive material includes mineral fibre processed from rock or slag with a thickness of 90 mm and 2.8 kg/m².
- 11) IIC values given are for floors tested with no finished flooring.
- 12) The FRR values given only apply to systems solid wood joists spaced not more than 400 mm o.c. No information is available on wood I-joists for these cases.

IMPACT OF INTEGRATING SERVICES IN FLOORS ON FIRE- RESISTANCE

There is little generic information available on the impact on fire-resistance of floor assemblies that accommodate electrical, water, plumbing or air-handling services. Certification agencies publish a wide variety of solutions for proprietary products or systems that can be used to ensure that the fire-resistance of a floor assembly is not degraded, for instance, when accommodating services such as recessed lighting fixtures. Designers and builders are advised to refer to these listings where specific products or systems are selected.

Calculation methods are not available to determine the fire-resistance of assemblies with integrated services. Penetrations in fire and acoustical separations, where practical, should be avoided. For assemblies with integrated services, "Appendix D" of the NBCC provides prescriptive approaches for duct openings in ceilings to reduce the likelihood that the assigned fire-resistance of the assembly is not compromised. These provisions are not available where the assigned rating is entirely attributable to the ceiling membranes using the values listed in Table 5.5, page 5-7. The NBCC provides that:

- 1) The ceiling membrane(s) may be penetrated by openings leading to ducts within the concealed spaces above the membrane(s) provided:
 - (a) The assembly is not required to have a fire-resistance rating in excess of 1 h.
 - (b) The area of any openings does not exceed 930 cm² (144 in.²) (see (2) below),
 - (c) The aggregate area of the openings does not exceed 1 per cent of the ceiling area of the fire compartment,
 - (d) The depth of the concealed space above the ceiling is not less than 230 mm (9 in.),
 - (e) No dimension of any opening exceeds 310 mm (12 in.),
 - (f) Supports are provided for openings with any dimension exceeding 150 mm (6 in.) where framing members are spaced greater than 400 mm (16 in.) o.c.,
 - (g) Individual openings are spaced not less than 2 m (6 ft. 5 in.) apart,
 - (h) The ducts above the membrane are sheet steel and are supported by steel strapping firmly attached to the framing members, and
 - (i) The clearance between the top surface of the membrane and the bottom surface of the ducts is not less than 100 mm (4 in.).
- 2) Where an individual opening permitted in (1) exceeds 130 cm² (20 in.²) in area, it must be protected by either:
 - (a) A fire stop flap conforming to the requirements of the NBCC; or
 - (b) Thermal protection above the duct consisting of the same materials as used for the ceiling membrane, mechanically fastened to the ductwork and extending 200 mm (8 in.) beyond the opening on all sides (see Figure 5.3, page 5-17).

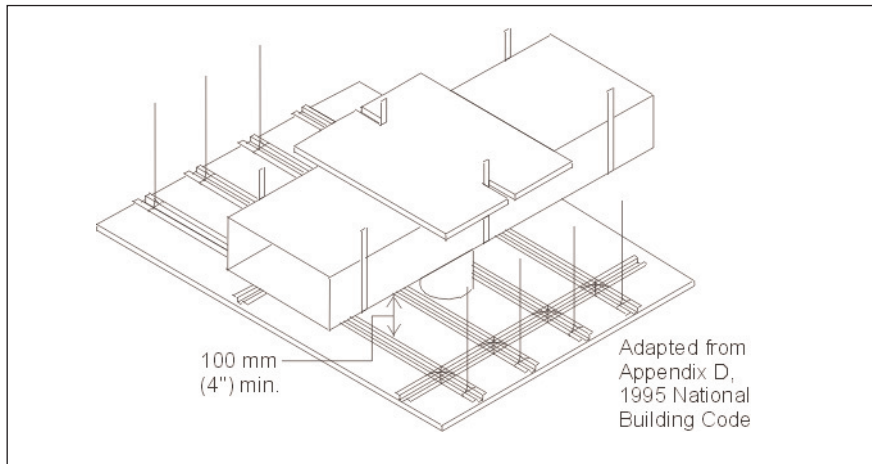

Figure 5.3: Thermal protection above a duct

The NBCC provisions that address the restrictions on service penetrations incorporated into fire-rated assemblies apply generically to both walls and floors that are constructed as fire separations. Refer to Chapter 4 for information on reducing the impact of integrating services.

When dealing with renovation of existing buildings, raised floors installed over a wood-framed floor assembly that is required to have a fire-resistance rating will generally have no effect on the fire-resistance provided the underlying assembly has all of the required features required for the rating. No additional contribution (or decrease) in fire-resistance should be considered for such raised floors provided there is a furring space between the base floor assembly and the raised floor to allow heat to escape in the event of fire exposure from below. If heat cannot escape, the fire-resistance of the base assembly may be degraded due to increased temperatures on structural members.

The fire-resistance of floor assemblies, like their vertical counterparts, depends on many variables. Key to understanding fire-resistant floor assemblies is realizing the gypsum board membrane is the first line of defence. Its secure attachment and protection will significantly improve the fire performance of the floor. In place, it can protect the frame, as can some types of insulation that remain in place after the membrane comes down. Every aspect of construction needs to be considered in the final determination of the floor assembly's fire-resistance rating.

LIMITING FIRE SPREAD AT WALL-FLOOR INTERSECTIONS

In Chapter 2, fire stopping was described as a barrier to prevent fire spread in a concealed space or to fill gaps around penetrations in wall and floor assemblies designed as fire separations. In both cases, the purpose of this fire stopping is to help ensure the continuity of the fire separation at the point of penetration.

Materials used as fire stopping to separate concealed spaces (that is, ensure the continuity of the fire separation) are required to remain in place and prevent the passage of flames for at least 15 minutes when subjected to the standard fire

exposure. Figure 5.4 shows an example of a test arrangement that was developed to specifically look at fire spread and the performance of fire stop materials within a double-stud wall cavity penetrating a floor assembly designed as a fire separation.

Currently, designers and builders are permitted to use several generic fire stop materials in these wall assemblies, which are typically used in MFBs of wood-frame construction. The performance of these generic materials and other possible alternatives, as well as the need for fire stopping in such cases, are among topics that have been researched by NRCC and presented in NRCC Internal Report No. 770.³⁵

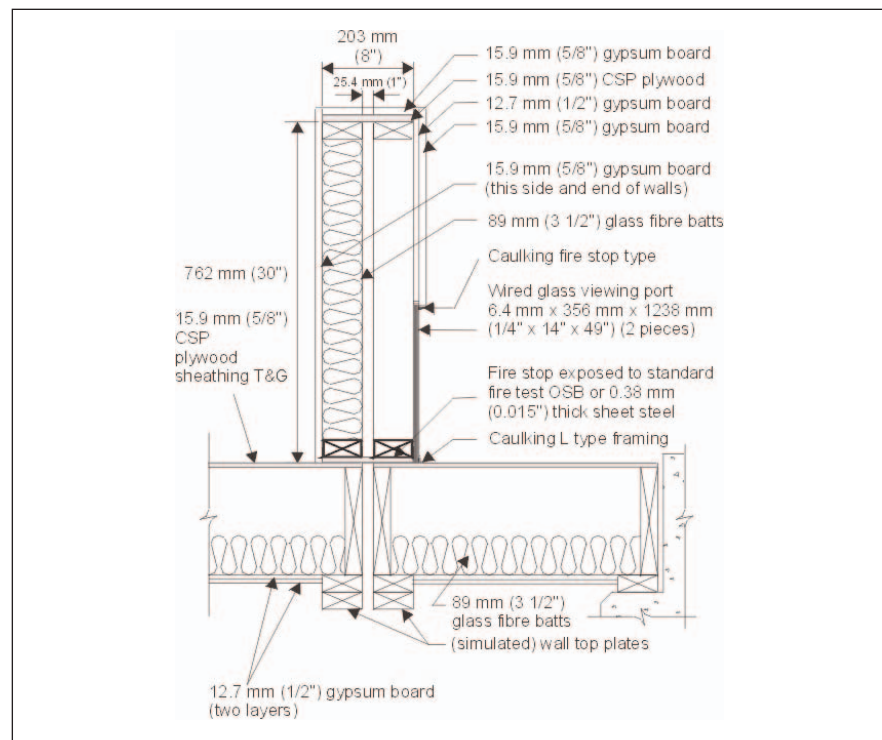

Figure 5.4: Test assembly for fire stop research

SEMI-RIGID INSULATION BOARDS

Figure 5.5, page 5-19, shows semi-rigid insulation boards used as a fire stopping material at the wall-floor joint with double-stud wall construction. Currently, this type of rigid insulation material is not recognized by the NBCC as an acceptable generic fire stopping material. However, the research showed that both rock and glass fibre semi-rigid insulation boards will prevent fire spread in the cavity for at least 52 minutes (in the prescribed test), which substantially exceeds the requirement of 15 minutes. Details presented in Chapter 6 show how this type of fire stopping might be used.

³⁵ "Fire Spread in Wall/Floor Joints in Multi-Family Dwellings," IRC-IR-770, 1998.

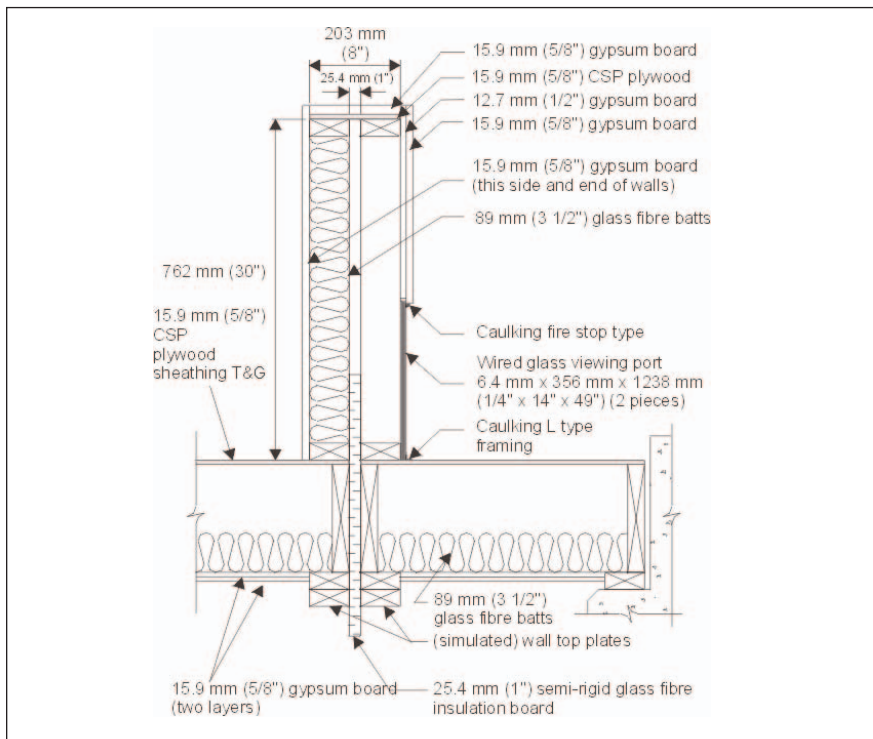

Figure 5.5: Using semi-rigid insulation board firestopping

SHEET STEEL AND OSB BARRIERS

The NBCC currently recognizes sheet steel not less than .38 mm thick and plywood or OSB not less than 12.5 mm thick as acceptable fire stopping material. As already shown in Figure 5.4, page 5-18, sheet steel or OSB (or plywood) can block the gap created at wall-floor intersections in double-stud construction. The research showed that 0.38 mm (.015 in.) thick sheet steel and 12.7 mm (1/2 in.) thick OSB were both capable of preventing fire spread in the cavity for at least 52 minutes (in the prescribed test), again in excess of the NBCC requirement of 15 minutes. The use of OSB or plywood can have serious flanking noise implications unless the subfloor is acoustically broken between suites or unless a floating floor system is used. Typically, a gap can provide protection against flanking noise transmission; however, its structural implications need to be carefully considered. Ensure adequate spacing to avoid future contact and possible squeaking. See Figure 5.6, page 5-20.

MINIMUM AIR CAVITY WIDTH TO PREVENT FIRE SPREAD

The NBCC describes a number of exceptions to the requirements for fire stopping in concealed spaces within wall assemblies. Fire stopping is not required in wall cavities filled with insulation with only one concealed air space that does not exceed 25 mm (1 in.) in horizontal width.

Further research was conducted to determine whether there was a minimum air gap width below which fire would not spread in a cavity at a wall-floor intersection in double stud-construction, as shown in Figure 5.6, page 5-20. For wood-frame construction using wood-stud walls, the research found that fire did not spread (for the 15-minute test duration) into the upper wall cavity when the gap was 12.7 mm (1/2 in.) or less. At a gap width of 25.4 mm (1 in.), fire

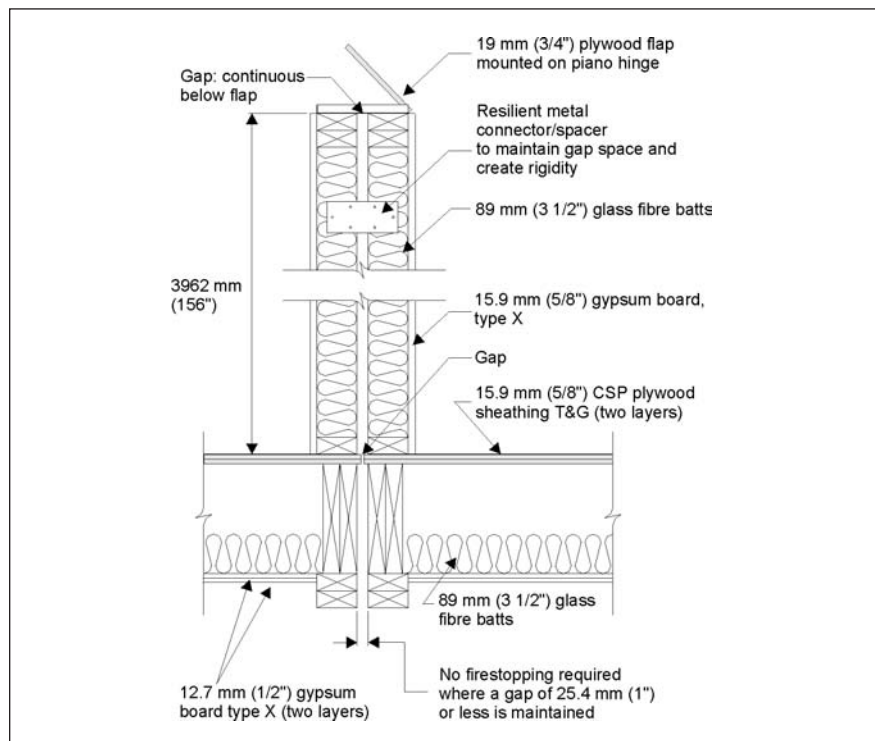

Figure 5.6: Testing air cavity widths

was observed to spread into the upper wall cavity at approximately 15 minutes. In the case where the gap was increased to 38.1 mm (1.5 in.), fire-spread to the upper cavity occurred within five minutes. Also, with these greater cavity widths, the extent of flame spread in the upper cavity increased over the duration of the tests (30 minutes). In a similar test using a double-steel stud wall, no fire-spread was observed with a gap width of 25.4 mm (1 in.) (for the 15-minute test duration).

The results of this research have identified other methods for fire stopping the concealed spaces in wall cavities using building materials that currently are not recognized in the NBCC. Revisions to the NBCC are currently being considered to extend the list of generic materials that are acceptable for these applications for fire stopping in concealed spaces. The results have also shown that the exception for fire stopping in the NBCC when the concealed space is very narrow is a reasonable approach.

As indicated in Chapter 2, fire-stopping materials around penetrations often use proprietary materials listed by certification agencies. However, like the generic materials allowed for fire stopping these concealed air spaces, in buildings constructed in accordance with Part 9 of the NBCC, a designer or builder is allowed to use generic fire stop materials around the penetrations such as mineral wool, gypsum plaster or Portland cement mortar.

SOUND CONTROL IN FLOORS

Approaches to controlling airborne sound transmission through floors are similar to those used for walls. Airborne sound transmission is best attenuated when the assembly includes two heavy layers that are not solidly connected at any point and that are separated by the thickest cavity possible, filled with sound-absorbing material.

Unlike walls, however, floors experience impact sound from people walking and objects being dropped or moved. Footstep noise and other impact sounds are common sources of annoyance in multi-family buildings. Currently, the NBCC does not contain any minimum requirements for floor assemblies regarding attenuation of impact sounds. Discussions are underway on possibly extending the NBCC to deal with impact sounds.

Impact sound insulation ratings are very dependent on the floor covering. The same basic floor structure can give extremely different IIC ratings simply by changing the floor covering. When occupants remove carpeting, the transmission of impact noise will increase substantially. Carpeting and any underpadding should be maintained to ensure optimum noise control.

While standard tests are available to measure impact sound transmission through floors, often, the ratings provided do not rank floors as would occupants listening to the low frequency thumping noises resulting from the footsteps of people walking across the floor of the unit above. This low frequency phenomenon is true even for wood-frame floors with carpeting. The carpet improves the floor's STC rating, but does little to attenuate low frequency impact sounds. The use of carpeting with underpad will often markedly improve IIC.

While the National Building Code requires an STC rating of at least 50, a minimum rating of 55 provides a high level of assurance of comfort to account for the degradation of sound insulation due to construction and design errors that introduce flanking transmission. **Best practices therefore suggest a minimum STC rating for floor systems of at least 55.** In essence, all typical wood-frame floor assemblies in order to meet these STC requirements will require a double gypsum board ceiling attached to the underside and an additional floor layer, excluding resilient flooring, applied over the basic subfloor.

While the National Building Code includes no provisions for impact insulation, best practices would suggest a minimum impact insulation class of 55. In most cases, this level of performance is achievable using traditional approaches to wood-frame construction only with carpeting and underlay or through use of floating floor systems. It should be clear that a floor's IIC rating that depends on carpet and underpad could be seriously compromised if tenants decide to remove them at some later date.

Sound Insulation of Floor Assemblies

- Joist floors without resilient channels do not achieve STC 50 in any practical configuration with or without sound absorbing material.
- Adding sound absorbing material to a cavity of a joist floor with a ceiling that is not resiliently suspended provides no significant increase in sound insulation.
- Adding resilient channels between two layers of gypsum board can reduce performance compared to assembly without resilient channels.

Reference:

Warnock, A.C.C., Birta, J.A., "Summary Report for Consortium on Fire Resistance and Sound Insulation of Floors: Sound Transmission Class and Impact Insulation Class Results", NRC, IRC Internal Report IRC-IR-766, 1997.

SOUND CONTROL FOR JOIST AND TRUSS FLOORS

Research has shown that the type of structural member used in a floor assembly (solid wood joist, wood I-joist, or metal plate-connected wood truss) does not significantly affect the STC or the IIC of the assembly. Table 5.6 gives STC and IIC ratings for some typical wood-frame floors. The values are based on an extensive series of measurements and can be used to estimate sound insulation for some specific floor types.

Table 5.6: STC and IIC ratings for floors

Number of layers		STC	IIC
Subfloors + topping	Ceiling		
1 + no topping	1	51	45
1 + no topping	2	56	49
2 + no topping	1	55	48
2 + no topping	2	58	52
1 + 35-mm (1-3/8 in.) concrete	1	67	40
1 + 25-mm (1 in.) gypsum concrete	1	65	28

From "Summary Report for Consortium on Fire Resistance and Sound Insulation of Floors: Sound Transmission Class and Impact Insulation Class Results," Warnock and Birta, IRC-IR-766, 1998.

Floor construction: 15 mm OSB subfloor, 240 mm deep joists @ 406 mm o.c., 152 mm glass fibre batts, resilient metal channels @ 610 mm o.c. and 15.9 mm gypsum board.

The testing results, which produced the STC and IIC ratings shown in Table 5.6, also identified factors that would affect these ratings.³⁶ The most notable among these are noted below:

- Doubling the total mass of the floor results in an improvement of about 7 dB in STC.
- Each additional 60 mm (2-3/8 in.) of sound-absorbing material will increase the sound insulation by about 1 dB.
- For framing members deeper than those noted in Table 5.6, the STC increases by 1 dB for each additional 115 mm (4-1/2 in.) of member depth. The IIC does not appear to depend on joist depth.
- Each increase of 150 mm (6 in.) in joist spacing will increase the STC by 1 dB and IIC decreases by 1.5 dB.
- Using fewer resilient metal channels gives better sound insulation; increasing spacing by 120 mm (4-3/4 in.) will increase STC and IIC by about 1 dB.

Impact Isolation for Floating Floors

A floating floor can achieve high impact insulation, (IIC 55 and up) where a hard finish floor is required.

Reference:

Bradley, C.W., "Sound Performance of Wood Floor/Ceiling Assemblies (Stage II)", CMHC, 1990.

³⁶ Warnock, A.C.C. and Birta, J.A., "Summary Report for Consortium on Fire-resistance and Sound Insulation of Floors: Sound Transmission Class and Impact Insulation Class Results," IRC-IR-766, 1998.

REDUCING IMPACT NOISE

REDUCING IMPACT SOUND WITH FLOOR COVERINGS

In typical wood-frame construction, where floors are constructed with a plywood or OSB subfloor over wood joists, I-joists or trusses, the IIC rating depends to a large extent whether resilient channels are used to attach the ceiling membrane(s) to the underside of the structural floor members.

When the finished floor covering installed over a plywood or OSB subfloor is hard, the floor covering does little to improve the IIC rating. At the same time, carpets and underpads can greatly increase the STC and IIC, but do little to reduce the transmission of low-frequency sound. Currently in North America, there is no simple method in use for comparing resilient floor coverings. While International Standards Organization (ISO) methods are available, none are currently in use in Canada.

Impact sound transmission through a floor assembly depends to a large extent on the finished surface material on the floor. Surface covering can significantly change the impact insulation characteristics of floors. For instance, adding a concrete topping to wood floors makes the impact sound worse at high frequencies despite the added weight, but substantially improves low-frequency impact insulation. Overall it has the effect of reducing the impact insulation class. Refer to Figure 5.7 and Table 5.6, page 5-22. Typically these floors require a floor covering, such as carpet and underpad, or floating floor to reduce the impact sound. Once this is done, the IIC rating is considerably improved. The final IIC rating depends on the type of covering used.

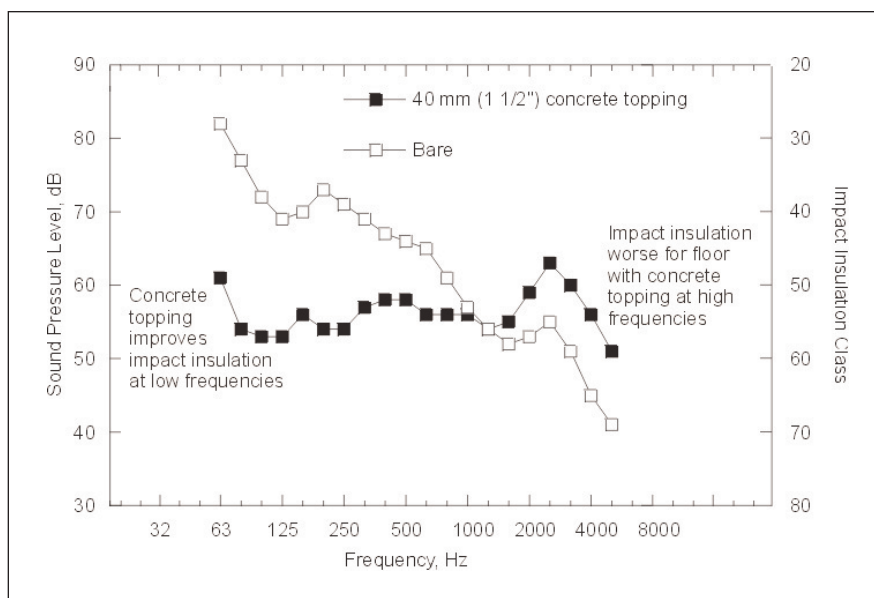

Figure 5.7: Effects of concrete topping on a wood joist floor assembly

Design and Installation of Floating Floors — Part 1

In designing and building a floating floor, take the following steps:

- Design the floating slab to have adequate structural strength for the load it is to support. The thickness will be determined in part by the method of support.
- Select a resilient support whose loadbearing characteristics are appropriate for the floating slab. For example, precompressed fibreglass floor isolation board used to support a concrete floating slab usually has a density of 64 to 192 kg/m³. Seal all edges of the floating floor with caulking so water cannot leak into an area below the slab.
- Ensure that the resilient support has the required life expectancy for both static and dynamic design loads.
- Ensure that the floating slab or wood raft will not contact the building structure. For example, fill the gap between the floating floor and the wall with a resilient material such as low density fibreglass to prevent contact between the edge of the floating floor and the wall.

Reference:

Warnock, A.C.C., "Sound Transmission Through Floors", CMHC, 1993.

REDUCING IMPACT SOUND WITH FLOATING FLOORS

If the floor surface is hard and a reasonable degree of impact-sound insulation is needed, the most efficient technique is to use a floating floor. In such floors, a slab or wood raft rests on a resilient material laid on the subfloor. Two illustrations of this type of construction are shown in Figure 5.8. The floating slab can be a concrete topping, a laminated gypsum concrete board or a lighter wood slab, while the resilient layer can be a continuous sheet or pads. As the figure shows, it is very important that there is no solid connection between the floating slab or wood raft and the walls around their periphery. Any connection will transmit impact sounds.

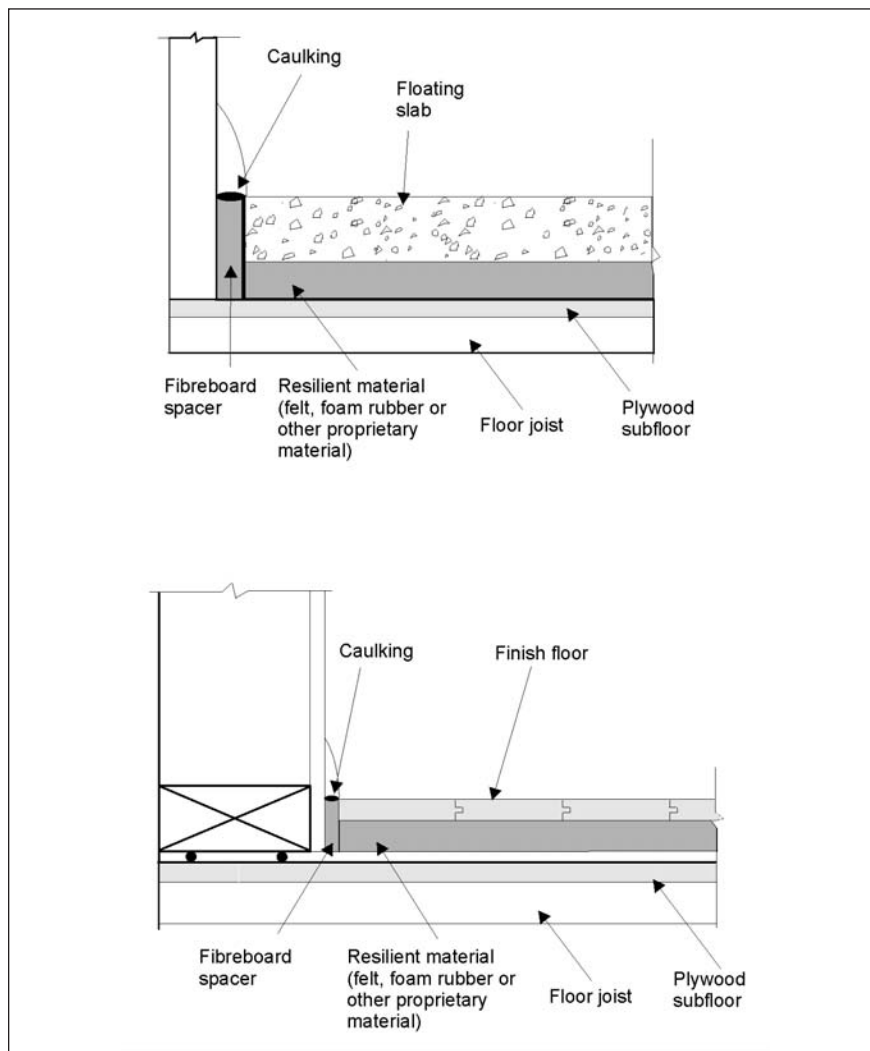

Figure 5.8: Floating floors

REDUCING IMPACT SOUND WITH PROPRIETARY FLOOR COVERINGS

A number of proprietary floor covers are available to improve the sound insulation characteristics of wood-frame floors. Many of these products are particularly suited to reducing impact-sound transmission. Individual manufacturers should be contacted. Materials will normally need to have been tested as part of an assembly.

REDUCING FLANKING NOISE AND OTHER UNINTENDED SOUND TRANSMISSION

IMPROPER CONSTRUCTION

Improper assembly and integration of components into floor systems can introduce unintended sound transmission and impact noise. Care needs to be taken over the smallest of details to avoid unintended sound transmission. For instance, debris between the two floor layers in a floating floor system can short-circuit the resilient layer. Similarly, using screws that are too long can also impair the sound insulation qualities of the floor system. See Figure 5.9.

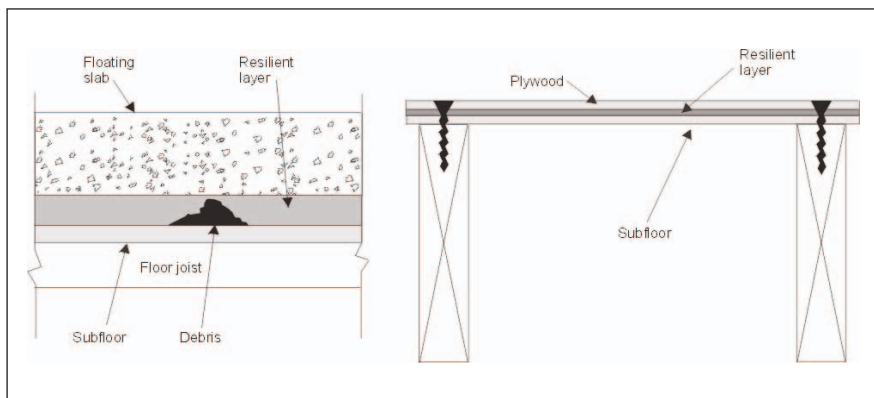

Figure 5.9: Short-circuiting resilient layers in floor assemblies

While resilient channels can effectively improve the STC and IIC of a floor system, installing them incorrectly can actually reduce the floor system's performance. Resilient channels installed between two layers of a gypsum board ceiling can create a small cavity that can seriously impair the floor's ability to attenuate sound. In a typical wood-frame floor assembly, an error in construction such as this could make a floor that would otherwise deaden loud music unable to prevent even normal speech from being heard from one suite to another. Figure 5.10, page 5-26, shows the reduction in STC and IIC for a typical wood-joint floor assembly with resilient channels placed in the unfavourable location.

Design and Installation of Floating Floors — Part 2

In designing and building a floating floor, take the following steps:

- Avoid penetrations of the floating floor by pipes, ducts, etc., but where a penetration is essential (as, for example, a drainage pipe), ensure that it does not form a rigid connection between the floating floor and the walls.
- Protect fibreglass material from possible water damage. For example, if precompressed fibreglass floor isolation board is used as the resilient support, protect the fibreglass with a plastic sheet to prevent moisture from the concrete topping from damaging the fibreglass.
- Before pouring a floating concrete topping, inspect the surface and the perimeter of the surface on which the concrete is to be poured to ensure they are not damaged.
- Ensure the structural floor is clean and smooth before laying down the resilient supports. This avoids short-circuiting of the floating concrete topping to the structure by debris.

Reference:

Warnock, A.C.C., "Sound Transmission Through Floors", CMHC, 1993.

Design and Installation of Floating Floors — Part 3

In designing and building a floating floor, take the following steps:

- Unless using a proprietary product that allows otherwise, before pouring a floating concrete slab, cover the resilient material or supports with plywood (or fibreboard); tape the joints between plywood sheets; cover the top surface of the plywood with an impervious plastic sheet to provide a surface on which to pour the floating slab and a hard surface to walk on during construction.
- Provide sufficient ventilation during the pouring and setting of a large concrete floating slab to carry away moisture.
- Do not use designs that require the upper layer to be held down by screws that penetrate the resilient layer and connect the floating floor to the structural floor. These screws “short circuit” the resilient layer and reduce sound insulation. Such designs are not true floating floors.

Reference:

Warnock, A.C.C., “Sound Transmission Through Floors”, CMHC, 1993.

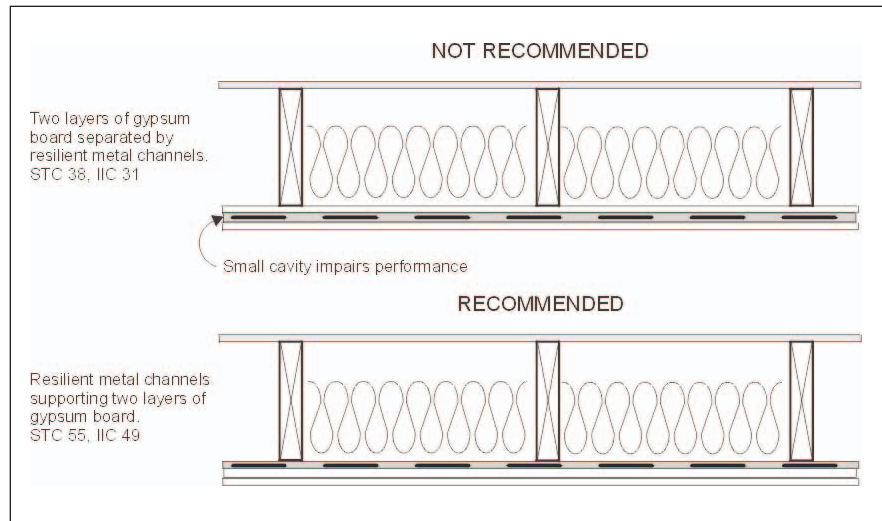

Figure 5.10: Incorrect use of resilient channels in floor assemblies

FLANKING NOISE

Sound energy can be transmitted around ceiling, wall and floor assemblies to reach adjacent rooms. Like heat moving through materials of high conductivity, sound can also move through solid objects around assemblies that would otherwise provide good sound attenuation. Flanking noise is sound that flanks around assemblies into adjacent spaces, as illustrated in Figure 5.11. Typically, sound transmission ratings do not account for this type of transmission, which can often reduce ratings by STC 3 or more.

When sound enters a structure and propagates as vibration, it can travel for considerable distances. The vibrating structure continually re-radiates energy as sound from both sides. Flanking paths tend to transmit impact sound much more than airborne sound. Impacts tend to transfer more vibrational energy to the structure-vibrational energy that tends to be of a lower frequency and that is much more difficult to control.

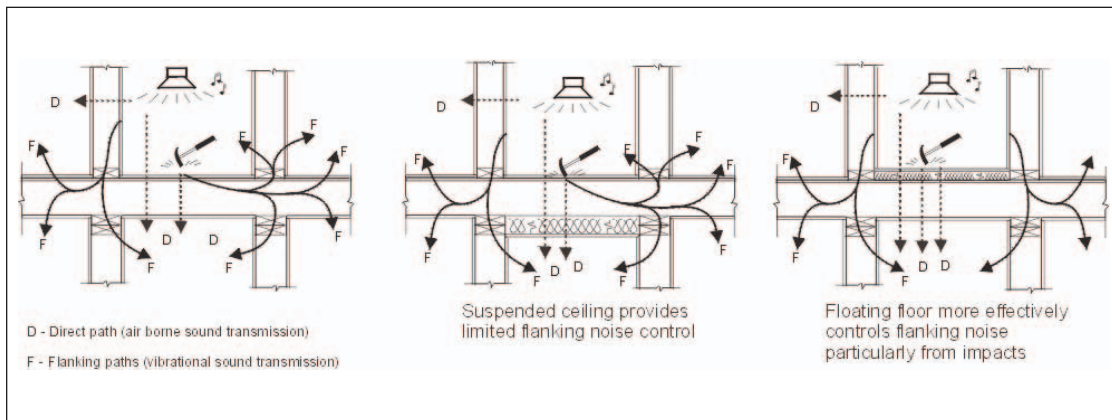

Figure 5.11: Controlling flanking noise

To provide the maximum possible sound attenuation in buildings, energy transmission along flanking paths should be reduced to a minimum by introducing breaks and resilient connections in the construction. While the frame of the building must be solid enough to give the structure strength, each dwelling unit should be an independent, resiliently supported unit within the building. The use of resilient metal channels and floating floors are practical approaches to uncouple suites.

The floating floor is an effective approach to breaking the flanking path along which sound travels to adjacent suites. If, for structural reasons, the floor must be rigidly connected to the adjoining and supporting walls, resiliently suspending the ceiling below the floor is an option to eliminate the flanking path to the suite below. The suspended ceiling does not, however, reduce in any way the flanking transmission paths to the adjacent rooms on the same level nor does it reduce the flanking transmission path down the walls. Additional resiliently supported wall and floor surfaces in the rooms would be required to reduce the remaining direct and flanking paths.

Where a floating floor is not used, the introduction of a structural discontinuity is also a way to reduce or prevent the passage of vibration along lightweight layers in the construction whether they be gypsum board, concrete, or wood. A break can be introduced in wood-joist construction by making a saw cut in the subfloor, as illustrated in Figure 5.12, or by constructing the two leaves of the double-stud demising wall so that they are independent. In some cases, structural integrity does not permit such construction breaks. In all cases, the break must be a designed-in feature considered as part of the building's structural analysis. In some cases, other approaches may need to be adopted to uncouple the suites.

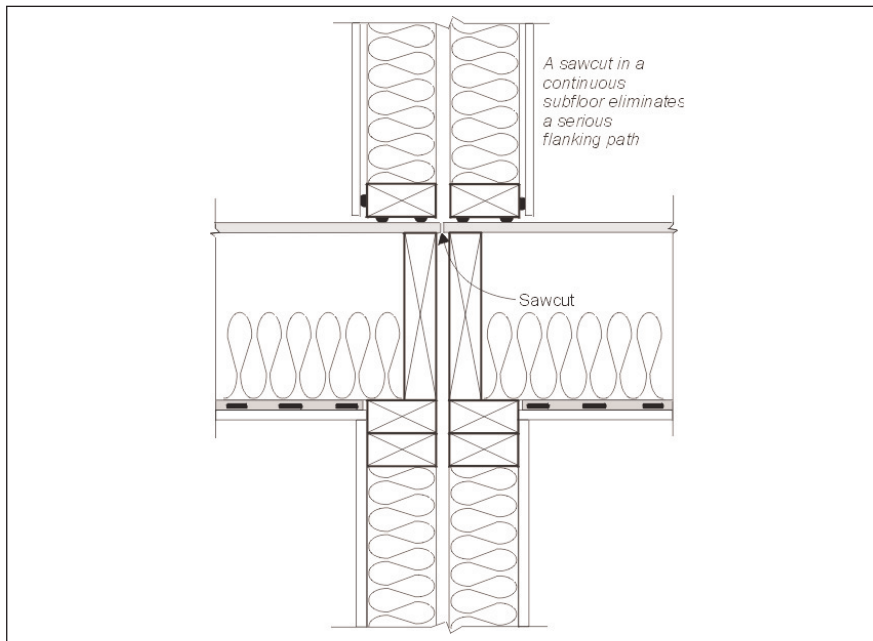

Figure 5.12: Eliminating flanking paths in wood-frame floors

Improving the Impact Sound Performance of Joist or Truss Floor Assemblies

To improve the impact sound insulation of joist or truss floor assemblies where no floating floor is used, examine ways to:

- Increase the mass of the floor layer. For example, add a layer of concrete, gypsum concrete board or two staggered layers of plywood over resilient underlayment.
- Increase the mass of the ceiling layer and be sure it is suspended resiliently from the floor construction. In critical situations, use neoprene and spring supports that provide a static deflection of about 15 mm when loaded by the ceiling.
- Fill the floor cavity between the ceiling and the floor at least 3/4 full with sound absorptive material if this has not already been done.
- Install a good quality carpet and soft underpad.

Flanking Sound Across Walls and Floors

Significant flanking noise can result with standard construction in double stud wall assemblies where the subfloor or exterior wall sheathing extends underneath or across the ends of the walls. A gap to reduce this sound transmission can be used at:

- The subfloor between the bottom plates of the double stud wall; or
- At the sheathing at the ends of the double stud wall where it meets another wall.
- Adequate fire stops must be provided where saw cuts are introduced. Where the building is subject to racking forces from wind or earthquake, the design and construction should be reviewed by a professional for structural sufficiency. As an alternative, a resilient or floating floor system can be used to reduce the effect of the flanking noise.

Reference:

Nightingale, T.R.T., "Study of Flanking Sound Transmission in Wood Framed Construction", CMHC, 1993.

Flanking sound can also propagate down walls to reach the room below as shown in Figure 5.13. Even though double studs are used for the party wall, there may be flanking transmission down the wall from dwelling units above that may be reduced using resilient channels on each side.

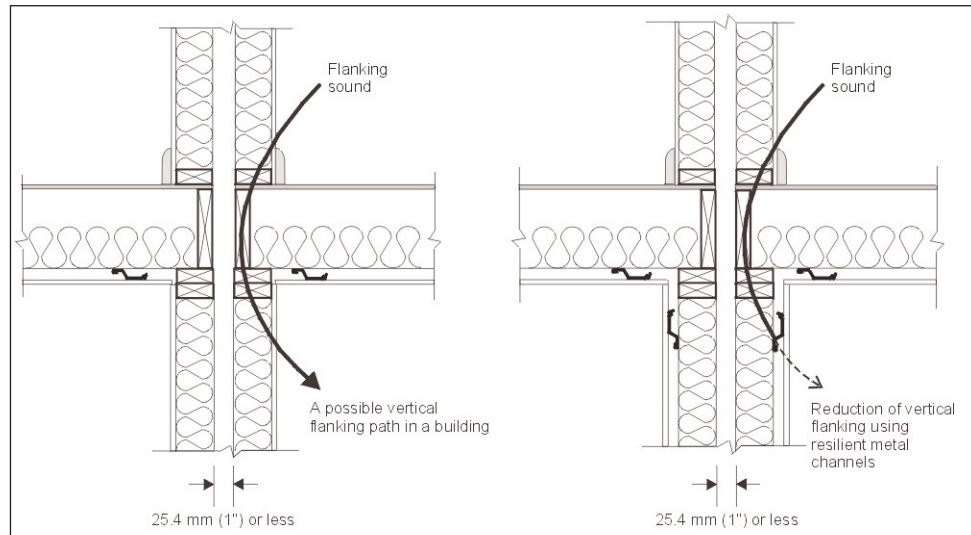

Figure 5.13: Eliminating vertical flanking paths

As shown in Figure 5.14, flanking noise can impair the performance of walls and floors that would otherwise have high STC ratings when tested individually. Yet, because of the transmission of vibration (flanking) along the top surface of the floor, the sound insulation between the two adjacent dwelling units is poor. The demising wall is "short-circuited" by the top layer of the floor. The same difficulty can exist with floating floors, which is also shown in the figure. The flanking may be avoided by introducing a break in the floating floor as shown.

Flanking Noise from Floor Joists

Physical contact between floor joists on opposite sides of a double stud party wall must be prevented.

Reference:

Nightingale, T.R.T., "Study of Flanking Sound Transmission in Wood Framed Construction", CMHC, 1993.

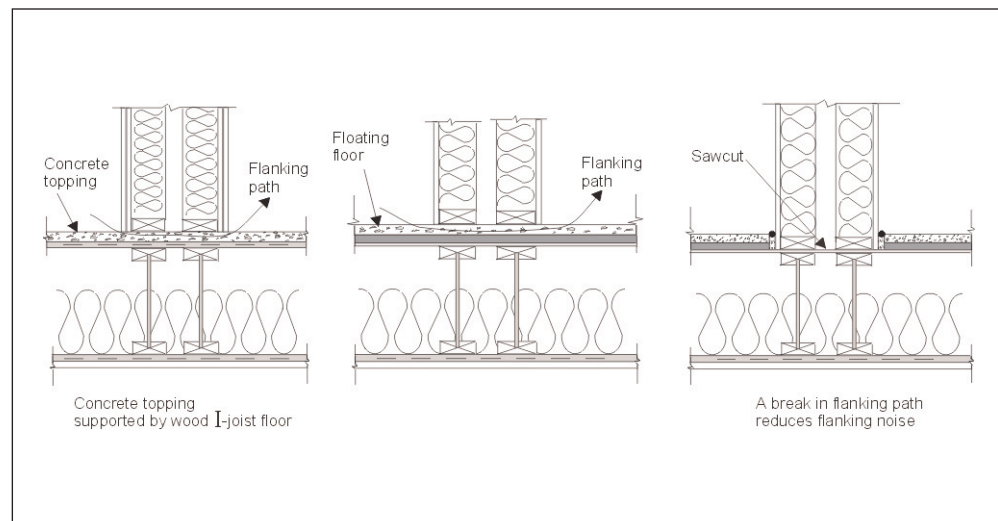

Figure 5.14: Flanking paths along concrete floor toppings

INTRODUCTION

The details presented here are included as CAD drawing files on the accompanying CD-ROM. They show various approaches to dealing with the issues raised in Chapters 2, 3, 4, and 5. In some cases, the detail as presented will need to be modified to accommodate the specific requirements established by the local authority having jurisdiction. The designer or builder should consult with the local authority prior to using any detail as part of a design. As well, a number of other guides and resources are available that can assist in the design and construction of wall and floor assemblies.

It should be clear that an assembly's ability to control the movement of fire and sound is but one of many functions that it must fulfill. Structural integrity, thermal protection, an ability to resist the movement of air and moisture, among others, are also important to the health, safety and well-being of the occupants. In assessing the suitability of a detail for a specific application consider all of the advantages and disadvantages an assembly offers.

Details to control fire spread and sound transmission must be considered carefully. Their construction demands care in execution to avoid problems that can be expensive, if not impossible, to correct. Each detail that is presented is accompanied by a facing commentary page. Common notes that apply to all details are shown below:

COMMON NOTES

FRR and STC for details

The fire-resistance rating and sound transmission class for each assembly is shown on the detail. In some cases ratings have been estimated where specific fire tests are not available. These details should be discussed with your local building official. Fire separations may or may not have a fire-resistance rating. Unrated assemblies have been noted.

Minimum required FRR and STC

The minimum required fire-resistance rating for wall and floor assemblies in wood-frame multi-family buildings is shown in Table 3.1, page 3-7. A 1 h. fire-resistance rating is required for walls and floors that separate dwelling units in four-storey buildings or where dwelling units contain more than one storey within the building. A 45 minute fire-resistance rating is permitted for walls and floors which separate dwelling units in buildings of three storeys or less, when the building is sprinklered or when the building area is less than 600 m² (6,458 sq. ft.). Walls and floors that separate dwelling units in multi-family buildings are required to have a sound transmission class of not less than 50. Walls and floors that separate units from elevator shafts or refuse chutes are required to have an STC of not less than 55.

Unrated floor assemblies

Where there is no dwelling unit above another dwelling unit, there is no requirement for a fire-resistance rating for floor assemblies contained entirely within a dwelling unit. In such cases, particular attention is needed at the floor-wall intersection between the units in order to ensure that the continuity of the vertical fire separation is maintained.

Sound-absorptive material

Where sound-absorptive material is shown, it is required to fill the entire cavity in order to achieve the STC rating noted in the detail. The sound-absorptive material must not overfill the cavity to the point of producing significant outward pressure on the finishes. For assemblies with double wood studs on separate plates, absorptive material is required in the stud cavities on both sides in order to achieve the STC rating shown in the detail. Absorptive material from glass, rock or slag may be used in assemblies requiring acoustical as well as fire-resistance ratings. However, where the absorptive material contributes to the fire rating of the assembly it must be mineral fibre processed from rock or slag with a mass of at least 4.8 kg/m² (.98 lbs/ft²), 2.8 kg/m² (.57 lbs/ft²) and 2.0 kg/m² (.41 lbs/ft²) for 150 mm (6 in.), 89 mm (4 in.) and 65 mm (2-1/2 in.) thickness, respectively. In the details shown, the FRRs are based on using batt insulation where no minimum density is required.

Fire stopping

Fire stopping must be installed as shown. Fire stopping installed in the air space between double walls at floor assemblies consisting of mineral fibreboard (glass fibre or mineral wool) should fit snugly in the space and be pinned at the top. Refer to the authority having jurisdiction. While research has shown this to be an acceptable fire stopping method, building codes generally have yet to be updated with the latest research. It should be noted that spaces less than 25 mm (1 in.) need not be fire stopped.

Acoustical caulking

Acoustical caulking where installed must be of a type that is non-hardening. Acoustical caulking must be applied around electrical boxes and other openings and at the junction of intersecting walls and floors.

Acoustical sealant is used to control air leakage across the separation and is essential to attaining the full potential sound insulation of the assembly.

Resilient channels

Ensure the resilient channels are oriented with their bottom flange attached to the wall stud framing.

Uncoupling units

Where subfloors are sawcut between units, a structural engineer may need to review plans and details to ensure the structure is sufficiently rigid to resist wind and seismic loading. Ensure adequate clearance to avoid contact that might result from movement and cause squeaking. Using continuous joists beneath separated units may introduce significant flanking noise, which will degrade the acoustical performance of the separation. Joists for floor assemblies should terminate at the edge of each double wall. Joists should frame into headers on each side of the assembly maintaining a gap between headers. Minimum bearing for floor framing must be maintained.

Structural integrity

In these details, solid sawn lumber may be used instead of wood I-joists where structurally appropriate. Wood I-joists acting as floor headers beneath load-bearing walls may require additional reinforcement (for example, squash blocks). All wood I-joists details should conform to manufacturer installation instructions.

DETAIL I—NON-LOADBEARING PARTY WALL

This detail may be used for the walls that separate two dwelling units or apartments in single-storey, multi-family buildings. It could also be used for the walls or floors that separate a unit or apartment from a hall or other common space. The detail shows conventional, non-load-bearing wood-frame wall construction supported on a concrete slab and using double layers of gypsum board with resilient channels on one side.

Notes

- To avoid flanking noise, do not nail through to the wood framing when attaching baseboards. Similarly, the gypsum board and anything fastened to it must be supported by the resilient channels only and not connected to the underlying frame.
- The fibreboard spacer provides a resilient support for the bottom edge of the gypsum board. Confirm acceptability with the authority having jurisdiction.
- Install a moisture barrier under the concrete slab.
- Apply a bead of acoustical sealant under the bottom wall plate. Apply a bead of caulking between the plate and fibreboard spacer and between the gypsum board and the fibreboard spacer. While not generally as effective, alternatively, a continuous bead of caulking can be applied at the subfloor-bottom plate corner prior to the installation of the fibreboard spacer and between the fibreboard and gypsum board.
- Insulation installed in these assemblies provides important sound attenuation benefits. Fill the entire cavity.
- All electrical penetrations should be tightly fitted and preferably sealed with acoustical caulking. Electrical boxes should be offset by at least 400 mm (16 in.) from boxes on the opposite side of the wall.
- Where possible avoid installing plumbing in these walls or floors.
- The rated wall assembly will need to extend to the underside of the roof sheathing; alternatively, a fire rated ceiling could be used.

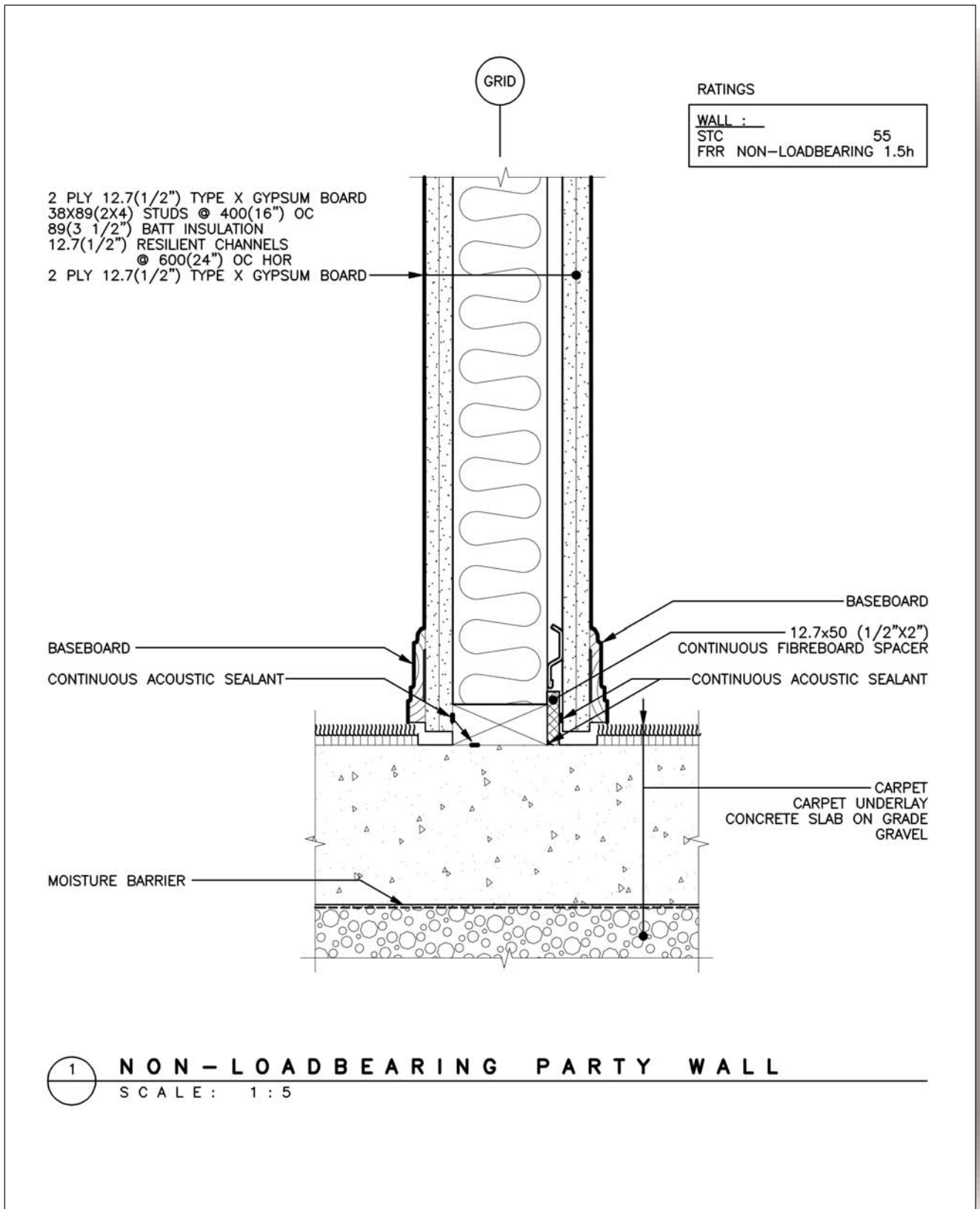

Detail 1: Non-Loadbearing Party Wall

DETAIL 2—PARTY WALL AT FLOATING FLOOR

This detail, similar to Detail 1, page 6-5, shows section through a party wall and floating floor. This detail may be used for the walls and floors that separate two dwelling units or apartments in multi-family buildings. It could also be used for the walls or floors that separate a unit or apartment from a hall or other common space. The detail shows conventional construction with double weight gypsum board for wall and ceiling finishes. This construction is recommended for applications where impact insulation is of concern. Flanking noise control is achieved by allowing floor surfaces to float over resilient acoustical underlay and by suspending ceilings on resilient channels.

Notes

- Insulation installed in these assemblies provides important sound attenuation benefits.
- To avoid flanking noise, do not nail through to the wood framing when attaching baseboards. Provide a continuous gap between the baseboard and the flooring to prevent sound transmission. Provide a backer rod and caulk in the gap between the drywall and the floating floor.
- Resilient acoustic underlay within the floor assembly provides improved impact sound insulation.
- The webs of the wood I-joists form the fire stop between the wall cavity and the adjacent floor cavities. As such, they must not be drilled unless gaps are tightly sealed.
- Where joists within the floor assembly span perpendicularly to the wall assembly, they must terminate at a header beneath the common wall.
- All electrical penetrations should be tightly fitted or sealed. Electrical boxes should be offset by at least 400 mm (16 in.) from boxes on the opposite side of the wall.
- Where possible, avoid installing plumbing in these walls.

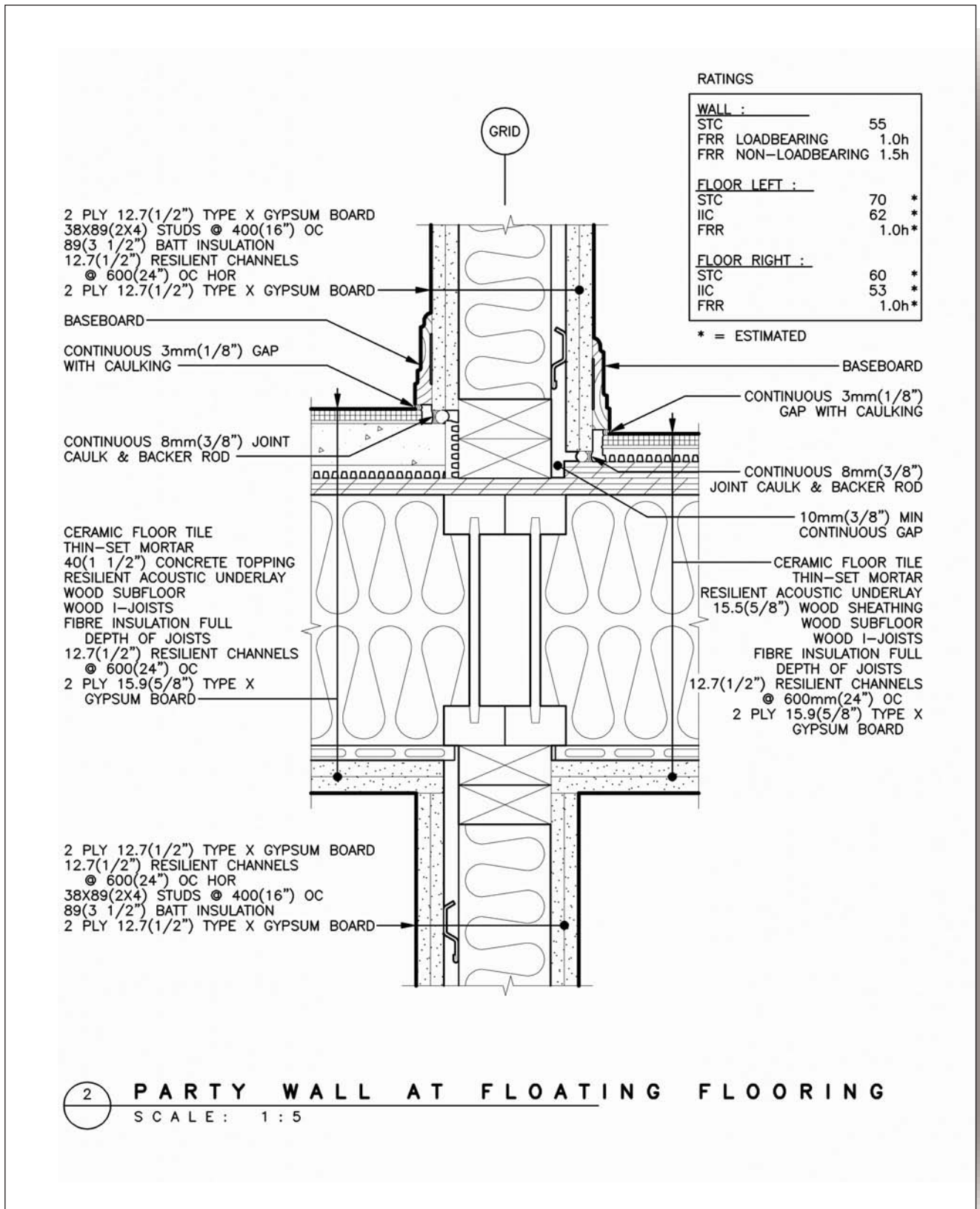

Detail 2: Party Wall At Floating Flooring

DETAIL 3—LOADBEARING PARTY WALL OR PARTITION

This wood-stud party wall detail is used to separate adjacent dwelling units or apartments. It could also be used for the walls or floors that separate a unit or apartment from a hall or other common space. The detail shows conventional construction with two layers of gypsum board for walls and for ceiling finishes. This approach to construction completely uncouples the two units including each of their structural frames.

Notes

- Carpet underlay within the floor assembly provides improved impact sound insulation.
- Apply a bead of acoustical sealant under the bottom wall plate between the plate and fibreboard spacer and between the gypsum board and the fibreboard spacer. Alternatively, apply a continuous bead of caulking at the subfloor/bottom plate corner prior to the installation of the fibreboard spacer and between the fibreboard and gypsum board.
- The fibreboard spacer provides a resilient support for the bottom edge of the gypsum board. Confirm acceptability with the authority having jurisdiction.
- Insulation installed in these assemblies provides important sound attenuation benefits. Fill the entire cavity.
- All electrical penetrations must be tightly fitted or sealed. Electrical boxes should be offset by at least 400 mm (16 in.) from boxes on the opposite side of the wall.
- Where possible, avoid installing plumbing in these walls.

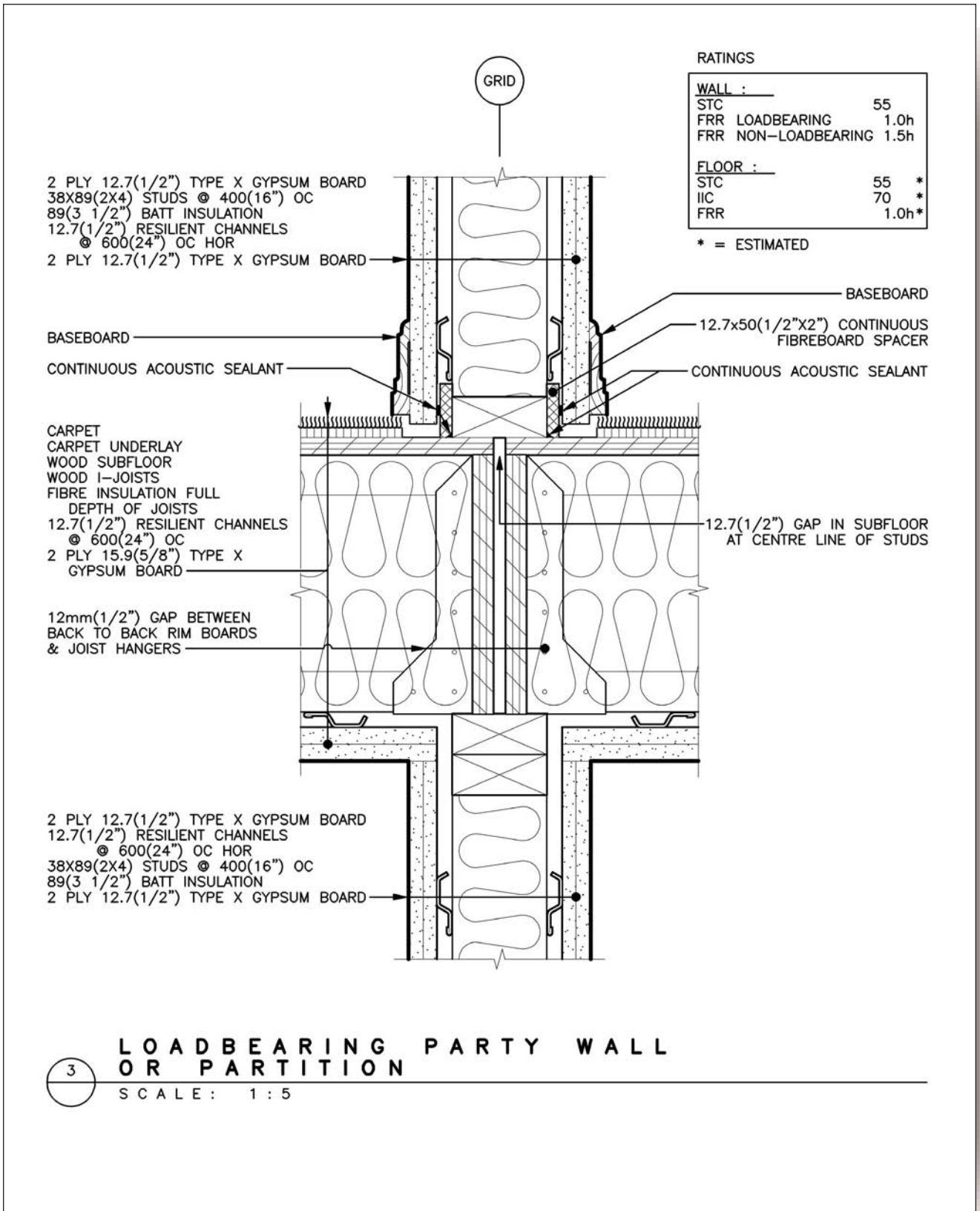

Detail 3: Loadbearing Party Wall or Partition

DETAIL 4—DOUBLE-STUD PARTY WALL

This detail can be used for the walls and floors that separate dwelling units in multi-family buildings. The detail shows conventional construction with single weight gypsum board for walls and double weight board for ceiling finishes. Floor assemblies are rated and provide a resilient separation.

Notes

- The two sides of the double stud walls are not rigidly connected to reduce the transmission of sound from one dwelling unit to another.
- Apply a bead of acoustical sealant under the bottom wall plate and between the bottom wall plate and the gypsum board.
- Insulation installed in these assemblies provides important sound attenuation benefits. The entire cavity should be filled.
- Fire stopping is provided by a 25 mm (1 in.) thick glass or mineral wool semi-rigid insulation board installed in the airspace at the floor assembly. Check for acceptability with your local authority. Where the air space is less than 25 mm (1 in.), no fire stopping is required.
- Where no ceiling finish is installed, for example in a basement, two layers of gypsum board can be used to provide fire protection at the header. See Detail 5, page 6-13.
- All electrical penetrations must be tightly fitted or sealed. Electrical boxes should be offset by at least 400 mm (16 in.) from boxes on the opposite side of the wall.
- Where possible, avoid installing plumbing in these walls.

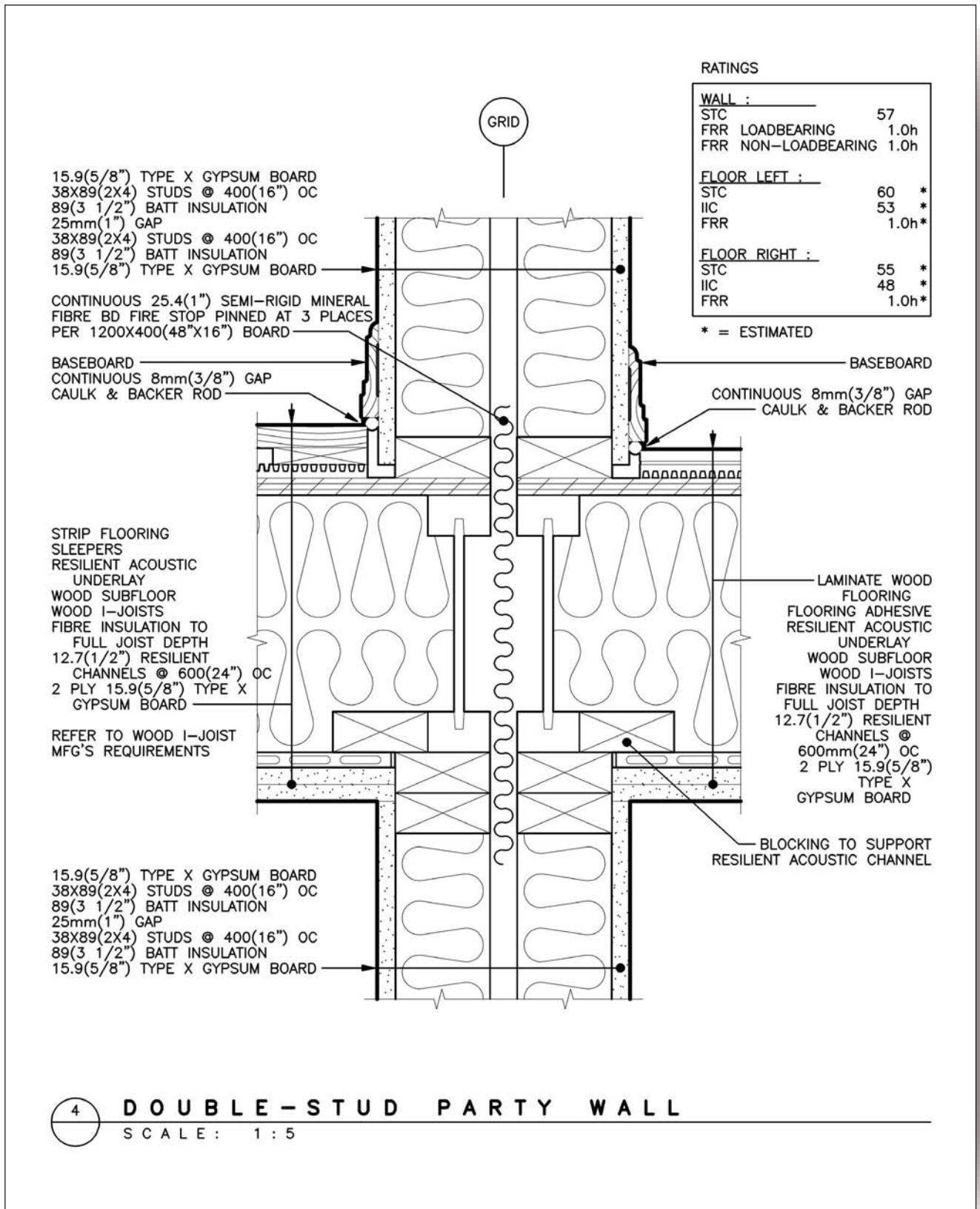

Detail 4: Double-Stud Party Wall

DETAIL 5—DOUBLE-STUD PARTY WALL—UNRATED FLOORS

This detail can be used for the walls that separate two dwelling units typically in a row configuration. The detail shows conventional construction with single weight gypsum board for walls and ceiling finishes. These details are used where there is no dwelling unit above another dwelling unit. As such, the floor assemblies that are contained entirely within each dwelling unit are unrated. Headers between units must be protected.

Notes

- Walls are not rigidly connected to reduce the transmission of sound from one dwelling unit to another.
- Apply a bead of acoustical sealant under the bottom wall plate and between the bottom wall plate and the gypsum board.
- Insulation installed in these assemblies provides important sound attenuation benefits. The entire cavity should be filled.
- Fire stopping is provided by a 25 mm (1 in.) thick glass or mineral wool semi-rigid insulation board installed in the airspace at the floor assembly. Check for acceptability with your local authority. Where the air space is less than 25 mm (1 in.), no fire stopping is required.
- All electrical penetrations must be tightly fitted or sealed. Electrical boxes should be offset by at least 400 mm (16 in.) from boxes on the opposite side of the wall.
- Where possible, avoid installing plumbing in these walls.

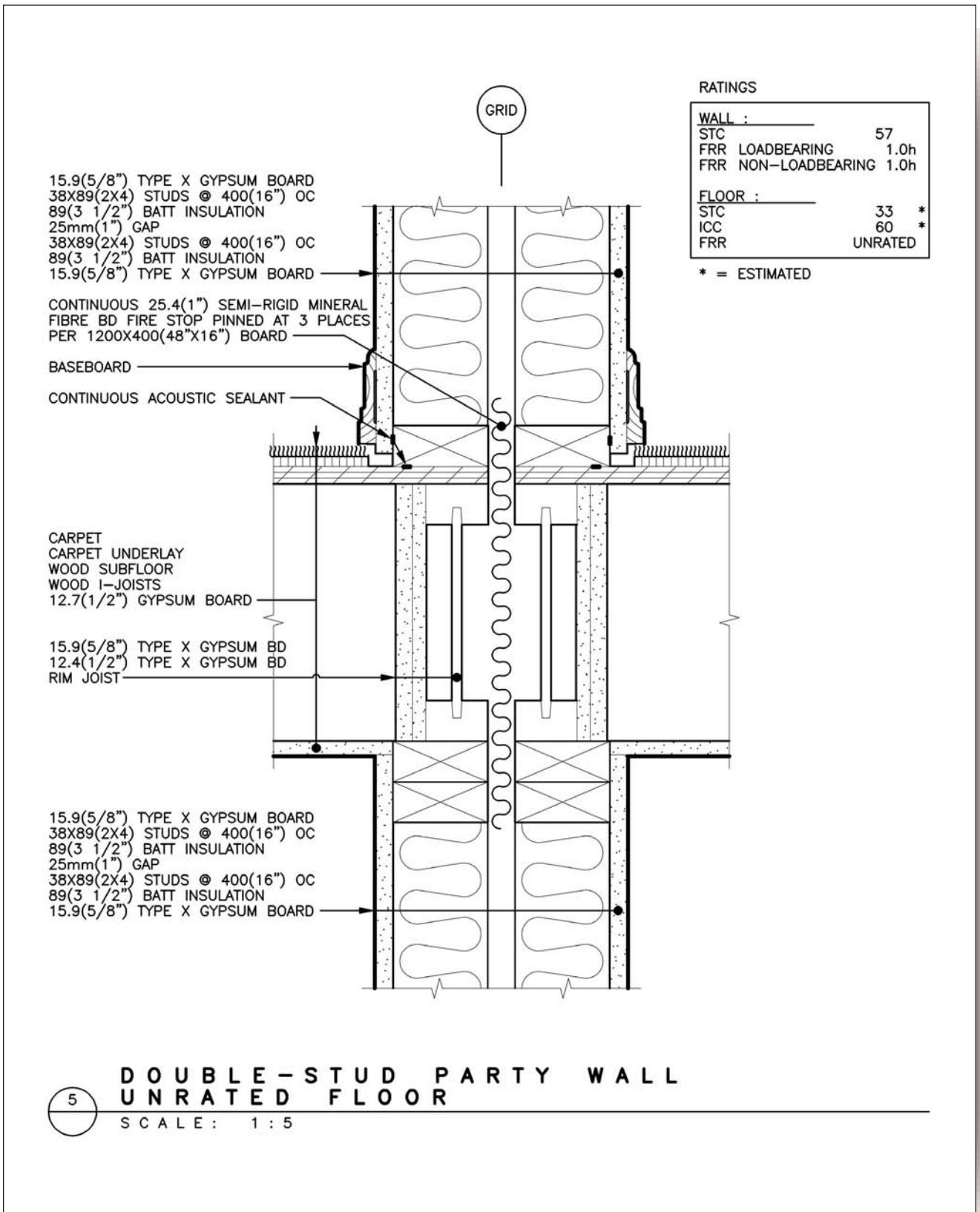

Detail 5: Double-Stud Party Wall—Unrated Floor

DETAIL 6—DOUBLE-STUD PARTY WALL AT OFFSET FLOORS

This detail, similar to Detail 5, page 6-13, can be used for the walls that separate two dwelling units typically in a row configuration where the floor from one unit is offset from the floor of the adjacent unit. The detail shows conventional construction with single weight gypsum board for walls and ceiling finishes. These details are used where there is no dwelling unit above another dwelling unit. As such the floor assemblies that are contained entirely within each dwelling unit are unrated. Headers supporting floor joists must be protected with fire rated gypsum board. This assembly has not been fire tested but represents a best practice in lieu of actual fire tests.

Notes

- Walls are not rigidly connected to reduce the transmission of sound from one dwelling unit to another.
- Apply a bead of acoustical sealant under the bottom wall plate and between the bottom wall plate and the gypsum board.
- Insulation installed in these assemblies provides important sound attenuation benefits. Fill the entire cavity.
- Fire stopping within the air space of the fire separation is provided by a 25 mm (1 in.) thick glass or mineral wool semi-rigid insulation board installed in the air space and extending from the bottom wall plate of the higher floor assembly to the top plate of the lower floor assembly. Check for acceptability with your local authority. Where the air space is less than 25 mm (1 in.), no fire stopping is required.
- All electrical penetrations should be tightly sealed. Electrical boxes should be offset by at least 400 mm (16 in.) from boxes on the opposite side of the wall.
- Where possible, avoid installing plumbing in these walls.

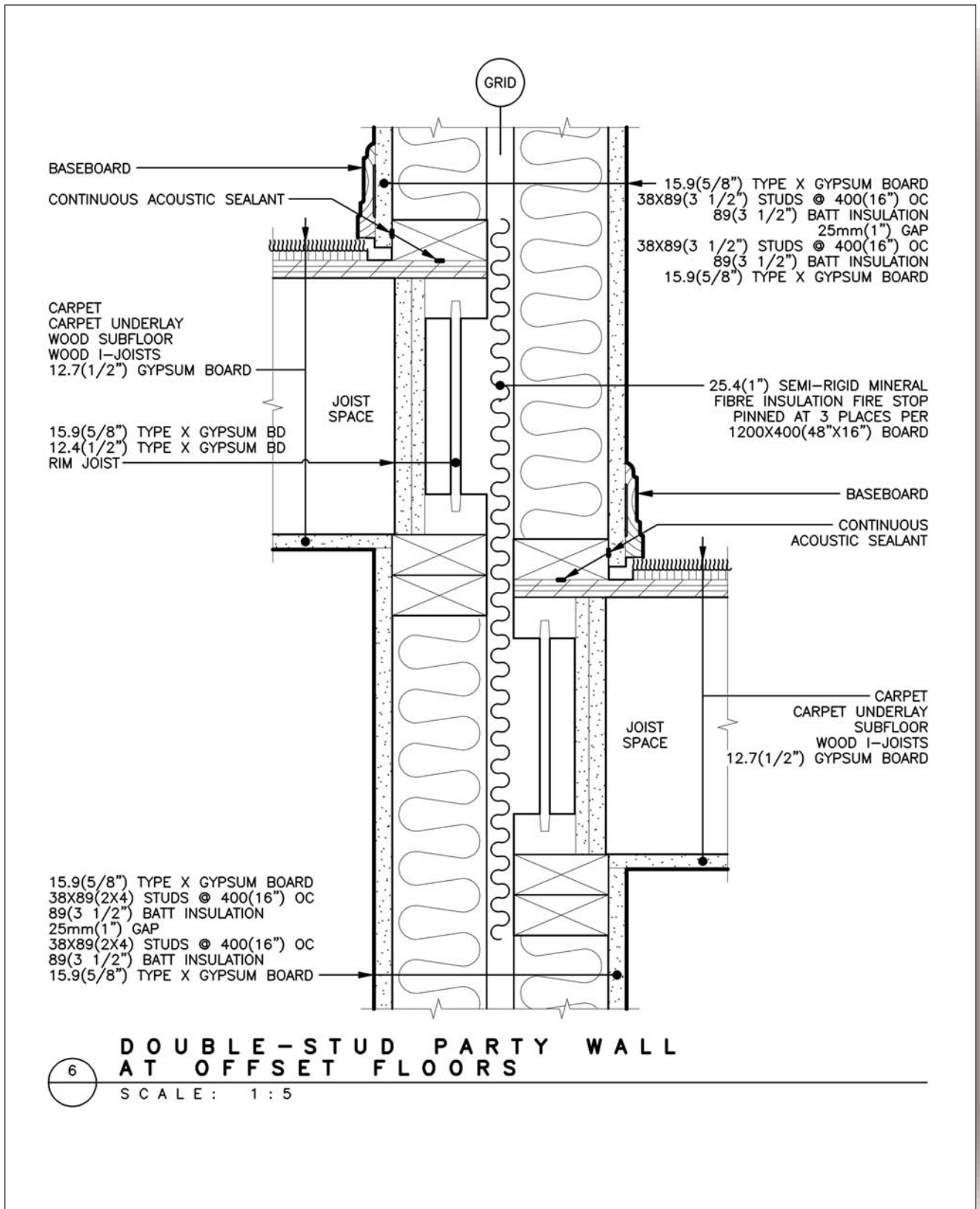

Detail 6: Double-Stud Party Wall At Offset Floors

DETAIL 7—DOUBLE-STUD WALL PLAN AT EXTERIOR WALL

This detail complements Detail 4, page 6-11, or Detail 5, page 6-13. It shows in plan how double-stud walls that separate dwelling units meet at an exterior wall. The detail shows conventional construction with single weight gypsum board for walls. While the exterior finish shown is stucco, other exterior finishes are possible.

Notes

- Stucco and sheathing are the only solid wall or floor elements that bridge the separation between dwelling units.
- To avoid condensation, install insulation in the air space created by the adjacent studs in the exterior wall. Provide continuity of the exterior wall insulation, air and vapour barriers across the gap in the double stud wall.
- Ensure all of the elements of the separation as identified in Detail 4, page 6-11, or Detail 5, page 6-13, are installed.

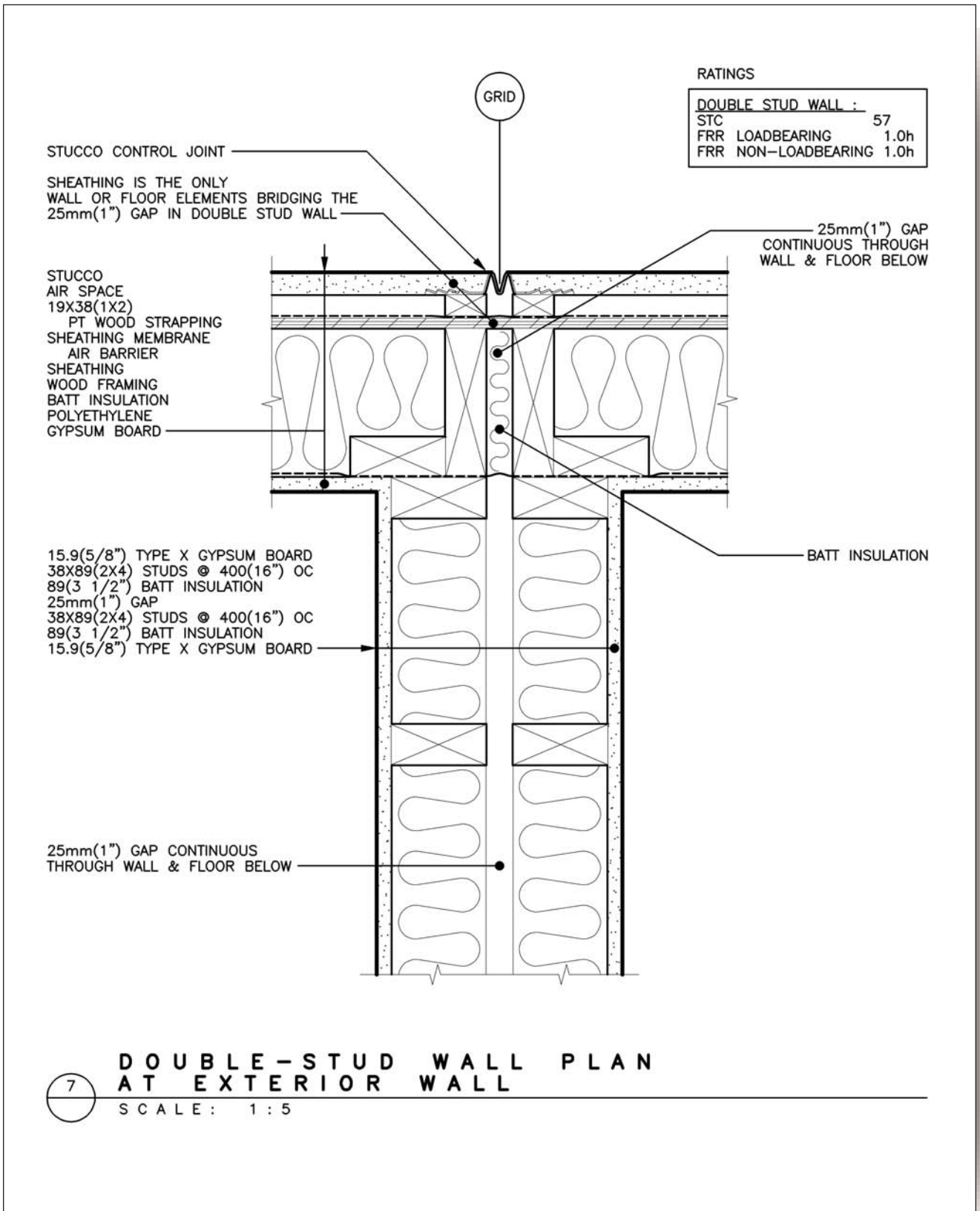

Detail 7: Double-Stud Wall Plan At Exterior Wall

DETAIL 8—DOUBLE-STUD WALL PLAN AT CORRIDOR

This detail complements Detail 4, page 6-11, or Detail 5, page 6-13. It shows in plan how walls that separate dwelling units meet at a corridor wall. The detail shows conventional construction with single weight gypsum board for walls, separating units and double weight board at the corridor. The corridor wall is resiliently separated from each dwelling unit with resilient channels.

Notes

- Install insulation in the corridor wall cavity including the space spanning dwelling units.
- Resilient channels need to be installed beneath the gypsum board of the walls of each unit.
- Ensure all of the elements of the separation as identified in Detail 4, page 6-11, or Detail 5, page 6-13, are installed.

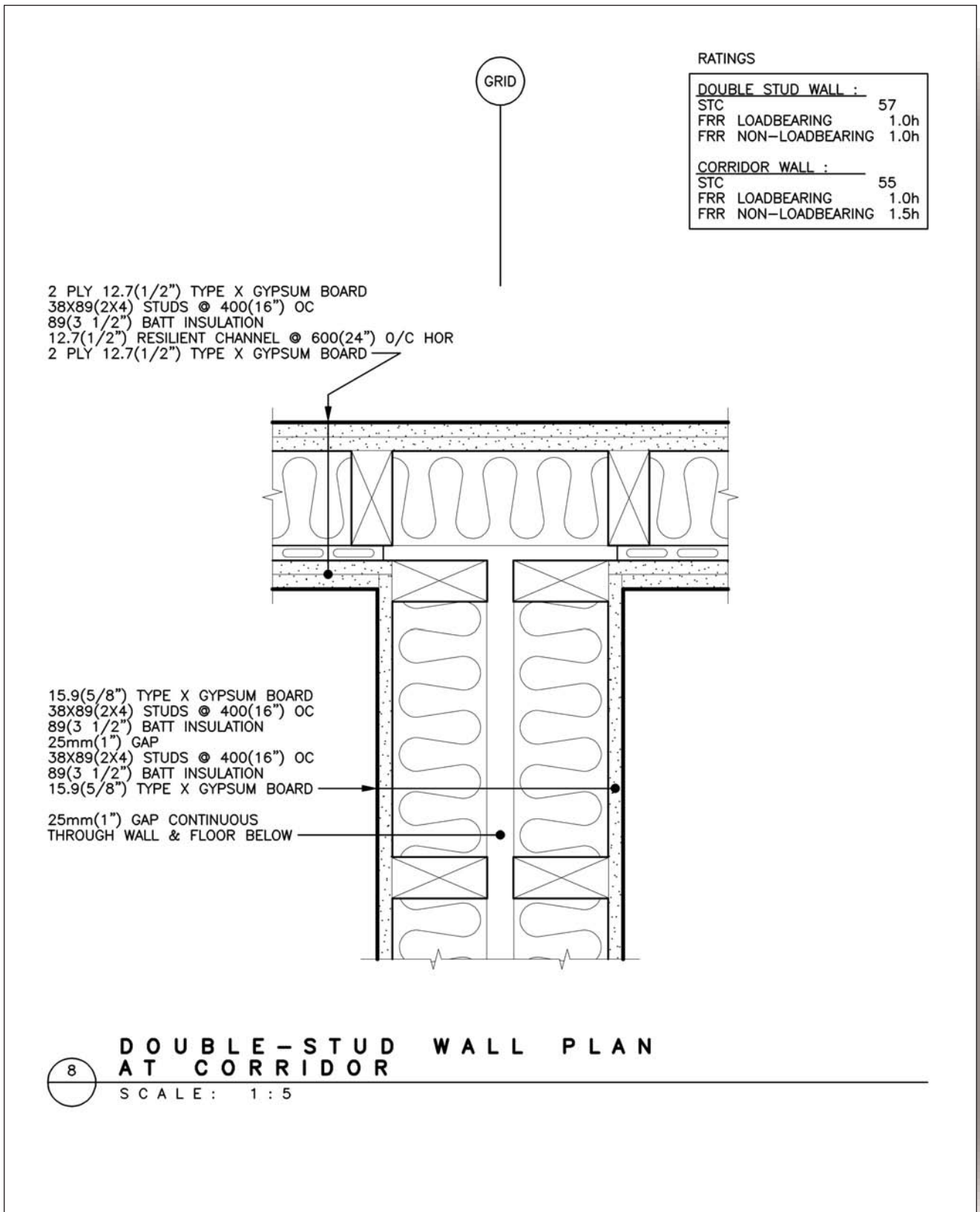

Detail 8: Double-Stud Wall Plan At Corridor

DETAIL 9—FIRE STOP CEILING BULKHEAD

This detail may be used for the walls and floors that separate dwelling units or apartments in multi-family buildings. It could also be used for the walls or floors that separate a unit or apartment from a hall or other common space. The detail shows conventional construction with single-weight gypsum board for wall and double-weight gypsum board for ceiling finishes. It also shows the construction of a bulkhead used as a design feature or used to enclose mechanical or electrical services.

Notes

- The carpet and underlay must be installed to provide insulation from impact noises.
- Apply a bead of acoustical sealant under the bottom wall plate and between the bottom wall plate and the gypsum board.
- Insulation installed in these assemblies provides important sound attenuation benefits. Fill both sides of the double wall and fill the floor cavity.
- Fire stopping within the air space of the fire separation is provided by a 25 mm (1 in.) thick glass or mineral wool semi-rigid insulation board installed in the air space and extending from the bottom wall plate of the higher floor assembly to the top plate of the lower floor assembly. Check for acceptability with your local authority. Where the air space is less than 25 mm (1 in.), no fire stopping is required.
- Gypsum board must be installed continuously behind the bulkhead to maintain the fire separation and to provide required fire stopping of the bulkhead cavity.
- Bulkhead furring must be attached to the resilient channels without contacting the wood framing beneath.
- Services should be hung from resilient mounts attached to the wall frame. All electrical penetrations should be tightly fitted or sealed. Electrical boxes should be offset by at least 400 mm (16 in.) from boxes on the opposite side of the wall.
- Where possible, avoid installing plumbing in these walls.

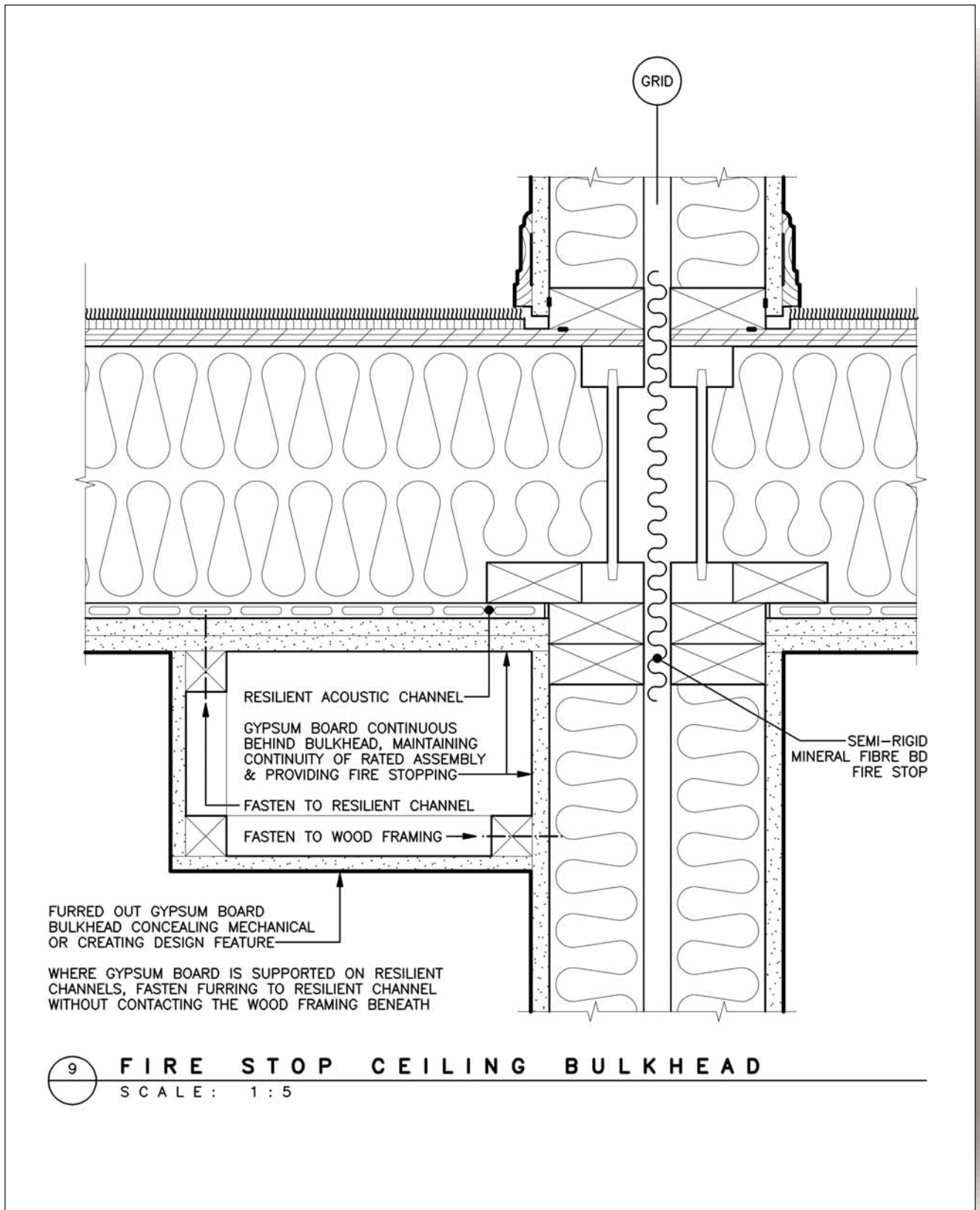

Detail 9: Fire Stop Ceiling Bulkhead

DETAIL 10—CONCRETE MASONRY UNIT WALL ASSEMBLY

This detail shows the use of concrete block to separate dwelling units or suites in a multi-family building. The floor assembly is hung from the concrete-block wall with joist hangers and anchor bolts. Wall finishes are not rigidly connected to the block wall. Ceiling finishes are not rigidly connected to the floor assembly.

Notes

- The carpet and underlay must be installed to reduce effects from impact noises. Resilient channels are used to uncouple the floor from the ceiling finish.
- Attach the baseboard to the strapping without contacting the concrete blocks.
- Apply a continuous bead of acoustical sealant at the bottom of the wood strapping. Maintain a gap between the concrete block and the subfloor. Insert a backer rod into the gap and seal with acoustical caulking. Apply another bead of sealant between the strapping at the bottom of the wall and the gypsum board.
- The insulation installed in these assemblies provides important sound attenuation benefits. The entire cavity created by the wood furring should be filled.
- All electrical penetrations must be tightly fitted or sealed. Electrical boxes should be offset by at least 400 mm (16 in.) from boxes on the opposite side of the wall.
- Where possible avoid installing plumbing in these walls.

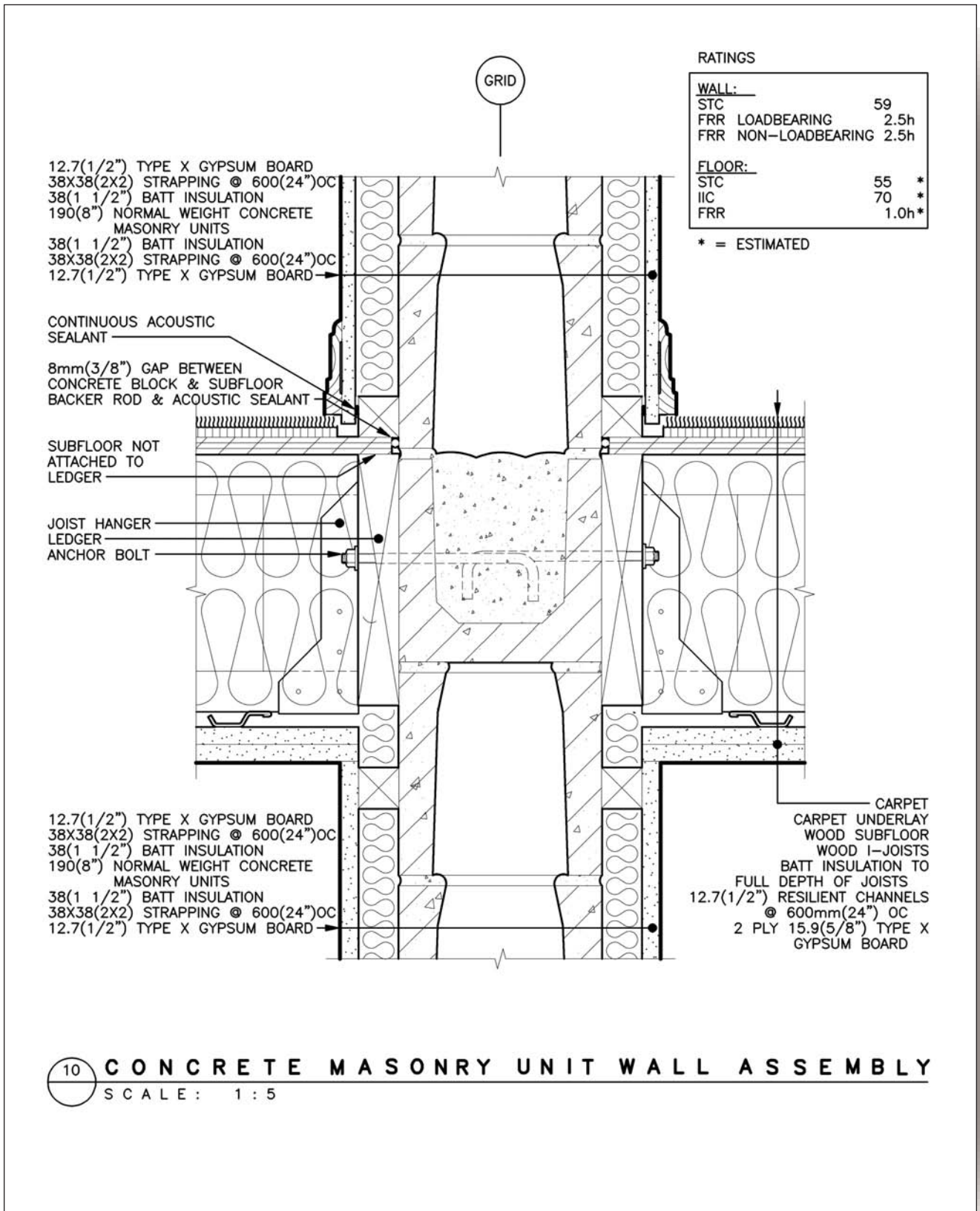

Detail 10: Concrete Masonry Unit Wall Assembly

DETAIL 11—STAIRS A FIRE SEPARATION

This detail shows how a stair is used to separate a dwelling unit from the suite below as in the case of stacked housing. While no fire test data exists for this type of detail, it represents a best practice. Conservatively, the fire-resistance rating is based on the membrane of the ceiling only.

Notes

- The carpet and underlay must be installed to reduce effects from impact noises. Resilient channels are used to uncouple the stair from the ceiling finish.
- Insulation installed in these assemblies provides important sound attenuation benefits.
- The cavity on the underside of the stair must be firestopped at the floor cavity at the top of the stairs.
- Care should be taken in the construction of the landing and side walls to avoid flanking paths that might result in unintentional flanking noise. Stair stringers are recommended to bear only at top and bottom of the stair to avoid side wall connections.
- The fire-resistance rating for the assembly is estimated to be at least the rating on the ceiling membrane alone.

RATINGS

STAIR :	
STC	50 *
FRR	1.0h*

* = ESTIMATED

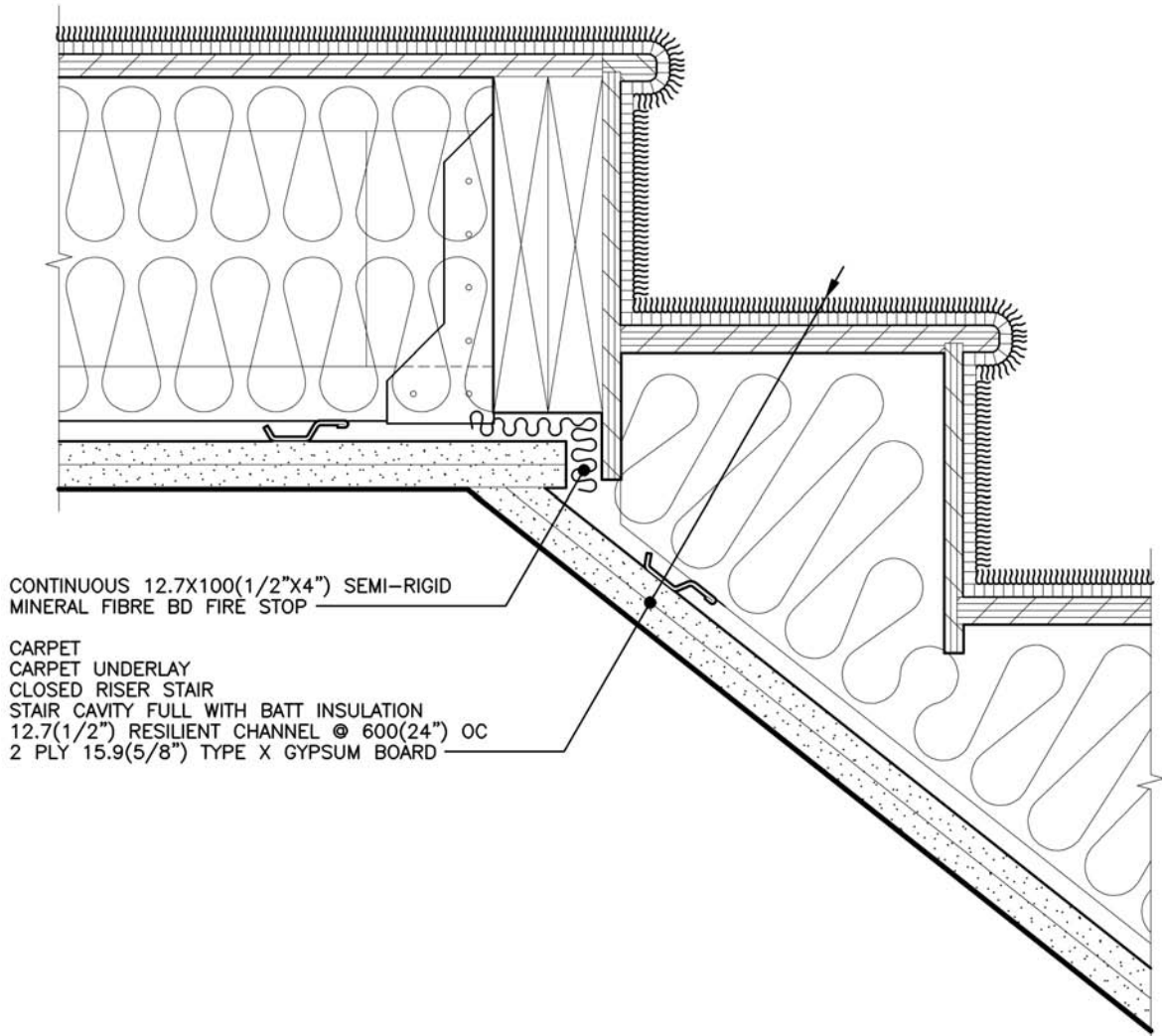

STAIR AS A FIRE SEPARATION

SCALE: 1:5

Detail 11: Stair As A Fire Separation

DETAIL 12—ELECTRICAL OUTLETS PLAN

This detail may be used for the walls that separate two dwelling units, typically in a row configuration. The detail using conventional construction with single-weight gypsum board for walls finishes, shows the installation of electrical outlets within walls intended to separate one dwelling unit from another.

Notes

- Electrical boxes must be sealed to the extent possible. Boxes should not be installed within the same stud space.
- Insulation should always be fitted behind the electrical boxes.
- As a best practice a stud space should separate boxes installed on either side of the separation.

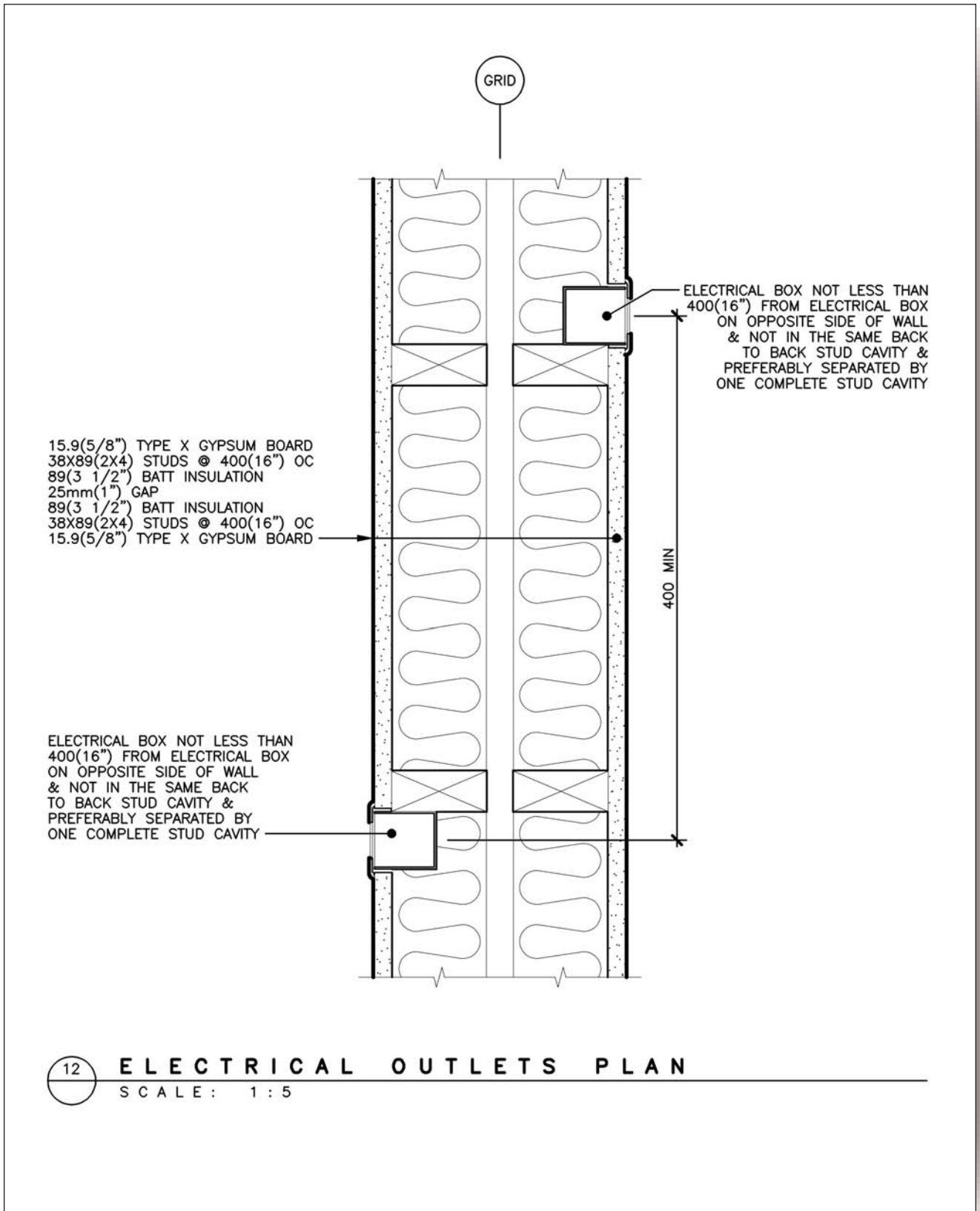

Detail 12: Electrical Outlets Plan

ACKNOWLEDGMENTS

This *Guide* was prepared for the Research Division, Canada Mortgage and Housing Corporation, by Michael Lio, Lio & Associates with the assistance of the Institute for Research in Construction, National Research Council of Canada.

The assistance of Ken Richardson and Dr. Alf Warnock who provided content expertise is gratefully acknowledged. Andrew Little prepared all details.

Members of the consulting team were:

Michael Lio

Lio and Associates, Toronto

Ken Richardson

Ken Richardson Fire Technologies Inc., Ottawa

Alf Warnock

National Research Council of Canada, Ottawa

Andrew Little

Andrew Little Architect, Calgary

Frank Palermo

Palermo Information Packaging, Toronto

Gregory Papp

Gregory Papp and Associates, Toronto

W.M. Tex McLeod

The McLeod Associates, Toronto

Roy Philippe

Roy Philippe Fire Protection Consultant Ltd., Toronto

Finally, the consultant wishes to thank and gratefully acknowledge CMHC's Project Manager, Ken Ruest, for the advice and direction he has provided throughout the entire project.